

IS 800 : 2007

भारतीय मानक  
इस्पात में सामान्य निर्माण — रीति संहिता  
( तीसरा पुनरीक्षण )

*Indian Standard*

GENERAL CONSTRUCTION IN  
STEEL — CODE OF PRACTICE

*( Third Revision )*

ICS 77.140.01

© BIS 2007

**BUREAU OF INDIAN STANDARDS**  
MANAK BHAVAN, 9 BAHADUR SHAH ZAFAR MARG  
NEW DELHI 110002

December 2007

Price Rs. 1130.00

## FOREWORD

This Indian Standard (Third Revision) was adopted by the Bureau of Indian Standards, after the draft finalized by the Structural Engineering and Structural Sections Sectional Committee had been approved by the Civil Engineering Division Council.

The steel economy programme was initiated by erstwhile Indian Standards Institution in the year 1950 with the objective of achieving economy in the use of structural steel by establishing rational, efficient and optimum standards for structural steel products and their use. IS 800 : 1956 was the first in the series of Indian Standards brought out under this programme. The standard was revised in 1962 and subsequently in 1984, incorporating certain very important changes.

IS 800 is the basic Code for general construction in steel structures and is the prime document for any structural design and has influence on many other codes governing the design of other special steel structures, such as towers, bridges, silos, chimneys, etc. Realising the necessity to update the standard to the state of the art of the steel construction technology and economy, the current revision of the standard was undertaken. Consideration has been given to the developments taking place in the country and abroad, and necessary modifications and additions have been incorporated to make the standard more useful.

The revised standard will enhance the confidence of designers, engineers, contractors, technical institutions, professional bodies and the industry and will open a new era in safe and economic construction in steel.

In this revision the following major modifications have been effected:

- a) In view of the development and production of new varieties of medium and high tensile structural steels in the country, the scope of the standard has been modified permitting the use of any variety of structural steel provided the relevant provisions of the standard are satisfied.
- b) The standard has made reference to the Indian Standards now available for rivets, bolts and other fasteners.
- c) The standard is based on limit state method, reflecting the latest developments and the state of the art.

The revision of the standard was based on a review carried out and the proposals framed by Indian Institute of Technology Madras (IIT Madras). The project was supported by Institute of Steel Development and Growth (INSDAG) Kolkata. There has been considerable contribution from INSDAG and IIT Madras, with assistance from a number of academic, research, design and contracting institutes/organizations, in the preparation of the revised standard.

In the formulation of this standard the following publications have also been considered:

- AS-4100 -1998 Steel structures (second edition), Standards Australia (Standards Association of Australia), Homebush, NSW 2140.
- BS-5950-2000 Structural use of steelwork in buildings:  
Part 1 Code of practice for design in simple and continuous construction: Hot rolled sections, British Standards Institution, London.
- CAN/CSA-S16.1-94 Limit states design of steel structures, Canadian Standards Association, Rexdale (Toronto), Ontario, Canada M9W 1R3.
- ENV 1993-1-1: 1992 Part 1-1 Eurocode 3: Design of steel structures: General rules and rules for buildings

The composition of the Committee responsible for the formulation of this standard is given in Annex J.

For the purpose of deciding whether a particular requirement of this standard, is complied with, the final value, observed or calculated, expressing the result of a test or analysis, shall be rounded off in accordance with IS 2 : 1960 'Rules for rounding off numerical values (*revised*)'. The number of significant places retained in the rounded off value should be the same as that of the specified value in this standard.

# Contents

<b>SECTION 1 GENERAL</b>	<b>1</b>
1.1 Scope	1
1.2 References	1
1.3 Terminology	1
1.4 Symbols	5
1.5 Units	11
1.6 Standard Dimensions, Form and Weight	11
1.7 Plans and Drawings	11
1.8 Convention for Member Axes	12
<b>SECTION 2 MATERIALS</b>	<b>12</b>
2.1 General	12
2.2 Structural Steel	12
2.3 Rivets	12
2.4 Bolts, Nuts and Washers	15
2.5 Steel Casting	15
2.6 Welding Consumable	15
2.7 Other Materials	15
<b>SECTION 3 GENERAL DESIGN REQUIREMENTS</b>	<b>15</b>
3.1 Basis for Design	15
3.2 Loads and Forces	15
3.3 Erection Loads	16
3.4 Temperature Effects	16
3.5 Load Combinations	16
3.6 Geometrical Properties	17
3.7 Classification of Cross-Sections	17
3.8 Maximum Effective Slenderness Ratio	20
3.9 Resistance to Horizontal Forces	20
3.10 Expansion Joints	21
<b>SECTION 4 METHODS OF STRUCTURAL ANALYSIS</b>	<b>22</b>
4.1 Methods of Determining Action Effects	22
4.2 Forms of Construction Assumed for Structural Analysis	22
4.3 Assumptions in Analysis	23
4.4 Elastic Analysis	24
4.5 Plastic Analysis	25
4.6 Frame Buckling Analysis	26
<b>SECTION 5 LIMIT STATE DESIGN</b>	<b>27</b>
5.1 Basis for Design	27
5.2 Limit State Design	28
5.3 Actions	28
5.4 Strength	29
5.5 Factors Governing the Ultimate Strength	30
5.6 Limit State of Serviceability	30
<b>SECTION 6 DESIGN OF TENSION MEMBERS</b>	<b>32</b>
6.1 Tension Members	32
6.2 Design Strength Due to Yielding of Gross Section	32
6.3 Design Strength Due to Rupture of Critical Section	32
6.4 Design Strength Due to Block Shear	33

<b>SECTION 7 DESIGN OF COMPRESSION MEMBERS</b>	<b>34</b>
7.1 Design Strength	34
7.2 Effective Length of Compression Members	35
7.3 Design Details	46
7.4 Column Bases	46
7.5 Angle Struts	47
7.6 Laced Columns	48
7.7 Battened Columns	50
7.8 Compression Members Composed of Two Components Back-to-Back	52
<b>SECTION 8 DESIGN OF MEMBERS SUBJECTED TO BENDING</b>	<b>52</b>
8.1 General	52
8.2 Design Strength in Bending (Flexure)	52
8.3 Effective Length for Lateral Torsional Buckling	54
8.4 Shear	59
8.5 Stiffened Web Panels	60
8.6 Design of Beams and Plate Girders with Solid Webs	63
8.7 Stiffener Design	65
8.8 Box Girders	69
8.9 Purlins and Sheeting Rails (Girts)	69
8.10 Bending in a Non-Principal Plane	69
<b>SECTION 9 MEMBER SUBJECTED TO COMBINED FORCES</b>	<b>69</b>
9.1 General	69
9.2 Combined Shear and Bending	69
9.3 Combined Axial Force and Bending Moment	70
<b>SECTION 10 CONNECTIONS</b>	<b>73</b>
10.1 General	73
10.2 Location Details of Fasteners	73
10.3 Bearing Type Bolts	74
10.4 Friction Grip Type Bolting	76
10.5 Welds and Welding	78
10.6 Design of Connections	81
10.7 Minimum Design Action on Connection	82
10.8 Intersections	82
10.9 Choice of Fasteners	82
10.10 Connection Components	82
10.11 Analysis of a Bolt/Weld Group	83
10.12 Lug Angles	83
<b>SECTION 11 WORKING STRESS DESIGN</b>	<b>84</b>
11.1 General	84
11.2 Tension Members	84
11.3 Compression Members	84
11.4 Members Subjected to Bending	85
11.5 Combined Stresses	85
11.6 Connections	86
<b>SECTION 12 DESIGN AND DETAILING FOR EARTHQUAKE LOADS</b>	<b>87</b>
12.1 General	87
12.2 Load and Load Combinations	87
12.3 Response Reduction Factor	87
12.4 Connections, Joints and Fasteners	87
12.5 Columns	87
12.6 Storey Drift	88
12.7 Ordinary Centrically Braced Frames (OCBF)	88

12.8 Special Concentrically Braced Frames (SCBF)	88
12.9 Eccentrically Braced Frames (EBF)	89
12.10 Ordinary Moment Frames (OMF)	89
12.11 Special Moment Frames (SMF)	90
12.12 Column Bases	90
<b>SECTION 13 FATIGUE</b>	<b>91</b>
13.1 General	91
13.2 Design	91
13.3 Detail Category	92
13.4 Fatigue Strength	93
13.5 Fatigue Assessment	99
13.6 Necessity for Fatigue Assessment	100
<b>SECTION 14 DESIGN ASSISTED BY TESTING</b>	<b>100</b>
14.1 Need for Testing	100
14.2 Types of Test	101
14.3 Test Conditions	102
14.4 Test Loading	102
14.5 Criteria for Acceptance	103
<b>SECTION 15 DURABILITY</b>	<b>103</b>
15.1 General	103
15.2 Requirements for Durability	103
<b>SECTION 16 FIRE RESISTANCE</b>	<b>105</b>
16.1 Requirements	105
16.2 Fire Resistance Level	105
16.3 Period of Structural Adequacy (PSA)	106
16.4 Variation of Mechanical Properties of Steel with Temperature	106
16.5 Limiting Steel Temperature	106
16.6 Temperature Increase with Time in Protected Members	107
16.7 Temperature Increase with Time in Unprotected Members	108
16.8 Determination of PSA from a Single Test	108
16.9 Three-Sided Fire Exposure Condition	108
16.10 Special Considerations	108
16.11 Fire Resistance Rating	109
<b>SECTION 17 FABRICATION AND ERECTION</b>	<b>110</b>
17.1 General	110
17.2 Fabrication Procedures	110
17.3 Assembly	112
17.4 Riveting	113
17.5 Bolting	113
17.6 Welding	113
17.7 Machining of Butts, Caps and Bases	113
17.8 Painting	113
17.9 Marking	114
17.10 Shop Erection	114
17.11 Packing	114
17.12 Inspection and Testing	114
17.13 Site Erection	114
17.14 Painting After Erection	116
17.16 Steelwork Tenders and Contracts	116

<b>ANNEX A LIST OF REFERRED INDIAN STANDARDS</b>	<b>117</b>
<b>ANNEX B ANALYSIS AND DESIGN METHODS</b>	<b>120</b>
B-1 Advanced Structural Analysis and Design	120
B-2 Second Order Elastic Analysis and Design	120
B-3 Frame Instability Analysis	120
<b>ANNEX C DESIGN AGAINST FLOOR VIBRATION</b>	<b>121</b>
C-1 General	121
C-2 Annoyance Criteria	121
C-3 Floor Frequency	121
C-4 Damping	122
C-5 Acceleration	122
<b>ANNEX D DETERMINATION OF EFFECTIVE LENGTH OF COLUMNS</b>	<b>122</b>
D-1 Method for Determining Effective Length of Columns in Frames	122
D-2 Method for Determining Effective Length for Stepped Columns ( <i>see 7.2.2</i> )	124
D-3 Effective Length for Double Stepped Columns	124
<b>ANNEX E ELASTIC LATERAL TORSIONAL BUCKLING</b>	<b>128</b>
E-1 Elastic Critical Moment	128
<b>ANNEX F CONNECTIONS</b>	<b>130</b>
F-1 General	130
F-2 Beam Splices	130
F-3 Column Splice	130
F-4 Beam-to-Column Connections	131
F-5 Column Bases	134
<b>ANNEX G GENERAL RECOMMENDATIONS FOR STEELWORK TENDERS AND CONTRACTS</b>	<b>135</b>
G-1 General	135
G-2 Exchange of Information	135
G-3 Information Required by the Steelwork Designer	135
G-4 Information Required by Tenderer (If Not Also Designer)	136
G-5 Detailing	137
G-6 Time Schedule	137
G-7 Procedure on Site	137
G-8 Inspection	137
G-9 Maintenance	137
<b>ANNEX H PLASTIC PROPERTIES OF BEAMS</b>	<b>138</b>

**AMENDMENT NO. 1 JANUARY 2012  
TO  
IS 800 : 2007 GENERAL CONSTRUCTION IN STEEL —  
CODE OF PRACTICE**

*(Third Revision)*

[(Page (iii), Section 17)] — Insert the following new item, as appropriate:

‘17.15 Bedding Requirement                      116’

(Page 6, line 38) — Delete the symbols ‘ $C_{my}$ ,  $C_{mz}$ ’ and the corresponding explanation.

(Page 8, line 33) — Insert the following symbols and explanations after this line:

‘ $K_y$ ,  $K_z$ ,  $K_{LT}$  — Moment amplification factors (see 4.4.2, 4.4.3.1, 4.4.3.3 and 9.3.2.2)’

(Page 18, Table 2, col 2) — Substitute ‘ $d/t$ ’ for ‘ $D/t_f$ ’ for entry against ‘Stem of a T-section, rolled or cut from a rolled I- or H-section’.

(Page 18, Table 2, col 3, 4 and 5) — Substitute ‘but  $\geq 42\varepsilon$ ’ for ‘but  $\leq 42\varepsilon$ ’ for entries against ‘Web of an I, H or box section’.

(Page 18, Table 2, Notes, last line) — Substitute ‘overall’ for ‘overll’.

(Page 19, Fig. 2, ROLLED CHANNELS) — Substitute ‘d’ for ‘h’ in the figure.

(Page 24, clause 4.4.2, line 10) — Substitute ‘ $K_y$ ,  $K_z$ ’ for ‘ $C_y$ ,  $C_z$ ’.

(Page 24, clause 4.4.3.1, line 9) — Substitute ‘ $K_y$  and  $K_z$ ’ for ‘ $C_y$  and  $C_z$ ’.

(Page 24, clause 4.4.3.3, line 3) — Substitute ‘( $K_y$ ,  $K_z$ )’ for ‘( $C_{my}$ ,  $C_{mz}$ )’.

(Page 25, clause 4.5.2, line 19) — Insert ‘less’ between ‘be’ and ‘than’.

(Page 31, clause 5.6.1, line 6) — Substitute ‘using load factors of Table 4.’ for ‘using a load factor of 1.0.’

(Page 31, clause 5.6.1, third sentence) — Insert the following at the end:

‘In Table 6, live load should include all post construction loads including superimposed dead loads.’

(Page 33, clause 6.3.3, line 6) — Substitute ‘ $0.9 f_u \gamma_{m0} / f_y \gamma_{m1}$ ’ for ‘ $f_u \gamma_{m0} / f_y \gamma_{m1}$ ’.

(Page 34, clause 7.1.2, line 1) — Substitute the following for the existing:

‘The factored design compression,  $P$  in members shall satisfy the following requirement:

$$P < P_d$$

(Page 34, clause 7.1.2.1, line 20) — Substitute ‘ $\gamma_{m0}$ ’ for ‘ $\lambda_{m0}$ ’.

**Price Group 3**

**Amend No. 1 to IS 800 : 2007**

(Page 35, Fig. 8)— Insert ‘ $\lambda$ ’ as the title of the abscissa (x-axis).

(Page 44, Table 10, col 2, line 3)— Substitute ‘ $40 \text{ mm} < t_f \leq 100 \text{ mm}$ ’ for ‘ $40 \leq \text{mm} < t_f \leq 100 \text{ mm}$ ’.

(Page 45, Table 11, second row, col 1 and 2)— Substitute the following for the existing entries:

(1)	(2)
Restrained	Free

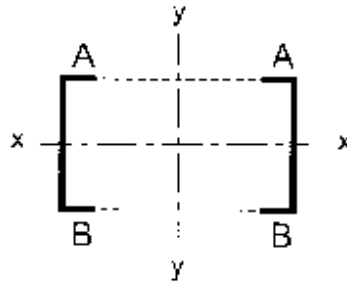
(Page 48, clause 7.5.1.2, line 4)— Add the following in the end:

“, in place of  $\lambda$  in 7.1.2.1 and using curve ‘c’ ( $\alpha = 0.49$ )”

(Page 48, clause 7.5.1.2, line 9, formula)— Substitute the following for the existing:

$$\lambda_{\text{vw}} = \frac{\left( \frac{l}{r_{\text{vw}}} \right)}{\varepsilon \sqrt{\frac{\pi^2 E}{250}}} \text{ and } \lambda_{\phi} = \frac{(b_1 + b_2) / 2t}{\varepsilon \sqrt{\frac{\pi^2 E}{250}}}$$

(Page 49, Fig. 10) — Substitute the following figure for the existing as appropriate, and substitute ‘Members’ for ‘Numbers’ in the sub-title of Fig. 10C and substitute the existing title of Fig. 10 with ‘TOP RESTRAINT CONDITIONS’:



(Page 53, clause 8.2.1.1, line 3)— Substitute ‘ $d/t_w > 67\varepsilon$ ’ for ‘ $d/t_w \leq 67\varepsilon$ ’.

(Page 54, clause 8.3.1, second para)— Substitute the following for the existing:

‘In simply supported beams with intermediate lateral restraints against lateral torsional buckling, the effective length for lateral torsional buckling,  $L_{LT}$  to be used in 8.2.2.1 shall be taken as the length of the relevant segment in between the lateral restraints. In the case of intermediate partial lateral restraints, the effective length,  $L_{LT}$  shall be taken as equal to 1.2 times the length of the relevant segment in between the partial lateral restraints.’

(Page 57, Table 14)— Substitute ‘ $L_{LT}/r_y$ ’ and ‘ $h/t_f$ ’ for ‘ $KL/r$ ’ and ‘ $h/t_f$ ’.

(Page 58, clause 8.3.2, line 9)— Insert ‘centre’ between ‘shear’ and ‘and’.

(Page 58, Table 15, col 3, first row)— Substitute ‘Both flanges partially restrained’ for ‘Both flanges fully restrained’.



(Page 59, clause 8.4.2.1) — Substitute ' $\epsilon_w$ ' for ' $\epsilon$ ' and ' $f_{yw}$ ' for ' $f_y$ ', wherever appearing.

(Page 60, clause 8.4.2.2, col 1, line 18 from top) — Substitute ' $c_{cr,e}$ ' for ' $c_{cr}$ '.

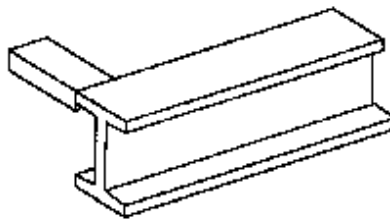
(Page 60, clause 8.4.2.2, col 2, line 52) — Substitute ' $\text{nearly} = \tan^{-1} \left( \frac{d}{1.5c} \right)$ ', for ' $\text{for} = \tan^{-1} \left( \frac{d}{c} \right)$ '.

(Page 60, clause 8.4.2.2, col 2, line 55) — Substitute ' $= d \cos\phi - (c - s_c - s_t) \sin\phi$ ', for the existing.

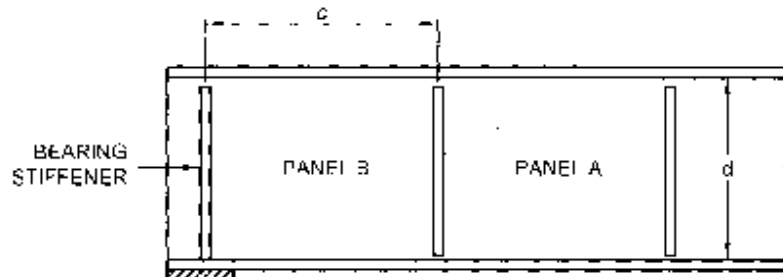
(Page 60, clause 8.4.2.2, col 2, lines 59 and 60) — Delete the lines.

(Page 60, clause 8.5.1, line 3) — Insert 'out' between 'carried' and 'in'.

(Page 61, Table 16, last row, col 1) — Substitute the following for the existing figure:



(Page 62, Fig. 12) — Substitute the following for the existing figure:



NOTES

- 1 Panel A is designed utilizing tension field action as given in 8.4.2.2(b).
- 2 Panel B is designed using simple post critical method as given in 8.4.2.2(a).
- 3 Bearing stiffener is designed for the compressive force due to bearing plus compressive force due to the moment  $M_t$  as given in 8.5.3.

FIG. 12 END PANEL DESIGNED NOT USING TENSION FIELD ACTION

(Page 63, Fig. 13, Notes) — Delete NOTE 2 and renumber the subsequent Note accordingly.

(Page 63, clause 8.6.1.1) — Substitute ' $\epsilon_w$ ' for ' $\epsilon$ ' wherever appearing.

(Page 63, clause 8.6.1.1, line 13) — Substitute ' $c < 0.74d$ ' for ' $c < d$ '.

**Amend No. 1 to IS 800 : 2007**

(Page 64, clause 8.6.1.2, line 15) — Substitute ‘ $\epsilon_f$  = yield stress ratio of flange =  $\sqrt{\frac{250}{f_{yf}}}$ ’, for ‘ $\epsilon_f$  = yield stress ratio of web =  $\sqrt{\frac{250}{f_{yf}}}$ ’.

(Page 65, clause 8.7.1.2, second para, line 1) — Insert ‘stiffener’ between the words ‘web’ and ‘is’.

[Page 70, clause 9.3.1.2(c)] — Substitute the following for the existing:

‘c) For standard I or H sections

$$M_{ndz} = 1.11 M_{dz} (1 - n) \leq M_{dz}$$

for  $n \leq 0.2$ ,  $M_{ndy} = M_{dy}$   
 for  $n > 0.2$ ,  $M_{ndy} = 1.56 M_{dy} (1 - n) (n + 0.6)$

(Page 72, Table 18) — Substitute the following for the existing table:

Bending Moment Diagram (1)	Range (2)		$C_{my}, C_{mz}, C_{mLT}$	
			Uniform Loading (3)	Concentrated Load (4)
	$-1 \leq \psi \leq 1$		$0.6 + 0.4 \psi \geq 0.4$	
	$0 \leq \alpha_s \leq 1$	$-1 \leq \psi \leq 1$	$0.2 + 0.8 \alpha_s \geq 0.4$	$0.2 + 0.8 \alpha_s \geq 0.4$
	$-1 \leq \alpha_s \leq 0$	$0 \leq \psi \leq 1$	$0.1 - 0.8 \alpha_s \geq 0.4$	$-0.8 \alpha_s \geq 0.4$
$-1 \leq \psi \leq 0$		$0.1(1-\psi) - 0.8 \alpha_s \geq 0.4$	$0.2(-\psi) - 0.8 \alpha_s \geq 0.4$	
	$0 \leq \alpha_h \leq 1$	$-1 \leq \psi \leq 1$	$0.95 - 0.05 \alpha_h$	$0.90 + 0.10 \alpha_h$
	$-1 \leq \alpha_h \leq 0$	$0 \leq \psi \leq 1$	$0.95 + 0.05 \alpha_h$	$0.90 + 0.10 \alpha_h$
		$-1 \leq \psi \leq 0$	$0.95 + 0.05 \alpha_h (1+2 \psi)$	$0.90 + 0.1 \alpha_h (1+2 \psi)$
For members with sway buckling mode, the equivalent uniform moment factor $C_{my} = C_{mz} = 0.9$ .				
$C_{my}, C_{mz}, C_{mLT}$ shall be obtained according to the bending moment diagram between the relevant braced points				
<i>Moment factor</i>	<i>Bending axis</i>	<i>Points braced in direction</i>		
$C_{my}$	$z-z$	$y-y$		
$C_{mz}$	$y-y$	$z-z$		
$C_{mLT}$	$z-z$	$z-z$		

(Page 75, clause 10.3.2, line 3) — Substitute the following for the existing:

$$V_{sb} \leq V_{db}$$

(Page 76, clause 10.4.3, first sentence) — Substitute the following for the existing:

‘Design for friction type bolting, where slip resistance is required at factored design force  $V_{sf}$ , shall satisfy the following:’

(Page 76, clause 10.4.3, line 14) — Substitute ‘ $\mu_f \leq 0.55$ ’ for ‘ $\mu_f = 0.55$ ’.

(Page 76, clause 10.4.3, Note, line 1) — Substitute ‘ $V_{nsf}$ ’ for ‘ $V_{ns}$ ’.

(Page 77, clause 10.4.5, col 1, line 6, from top, formula) — Substitute ‘ $0.9 f_{ub} A_n \leq f_{yb} A_{sb} (\gamma_{m1}/\gamma_{m0})$ ’ for ‘ $0.9 f_{ub} A_n \leq f_{yb} A_{sb} (\gamma_{m1}/\gamma_m)$ ’.

(Page 80, clause 10.5.10.2.2, line 7, formula) — Substitute ‘ $f_{br}^2$ ’ for ‘ $f_{bf}^2$ ’.

(Page 89, clause 12.8.2.1, first sentence) — Substitute the following for the existing:

‘Bracing members shall be made of E250B steel of IS 2062 or of steel having Charpy V-notch energy,  $E > 27J$ .’

(Page 90, clause 12.11.1, line 2) — Insert ‘or of steel having Charpy V-notch energy,  $E > 27J$ ’ between ‘IS 2062’ and ‘and’.

(Page 106, clause 16.4.1, line 4, formula) — Substitute ‘ $\frac{f_y(T)}{f_y(20)} = \frac{905 - T}{690} \leq 1.0$ ’ for the existing.

(Page 121, Annex B, clause B-3.2, line 10 from top, formula) — Substitute ‘ $\phi_{si} = \frac{\delta_{ui} - \delta_{Li}}{h_i}$ ’ for ‘ $\phi_s = \frac{\delta_u - \delta_L}{h}$ ’.

(Page 121, Annex B, clause B-3.2, lines 12, 13 and 16 from top) — Substitute ‘ $h_i$ ’, ‘ $\delta_{ui}$ ’ and ‘ $\delta_{Li}$ ’ for ‘ $h$ ’, ‘ $\delta_u$ ’ and ‘ $\delta_L$ ’.

(Page 128, Annex E, clause E-1.2, line 5, formula) — Substitute ‘ $(L_{LT})^2$ ’ for ‘ $(L_{LT})$ ’.

(Page 128, Annex E, clause E-1.2, line 30) — Substitute ‘ $(z^2 + y^2)^2$ ’ for ‘ $(z^2 - y^2)$ ’.

(Page 129, Annex E, clause E-1.2, col 1, line 18 from top) — Insert ‘St. Venant’s’ before ‘torsion’.

(Page 130, Table 42, col 5, row 7) — Substitute ‘1.267’ for ‘1.257’.

(Page 129, Table 42, col 6, rows 5 and 10) — Substitute ‘1.730’ for ‘1.780’ and ‘1.890’ for ‘1.390’, respectively.

(CED 7)

*Indian Standard*

**GENERAL CONSTRUCTION IN  
STEEL — CODE OF PRACTICE**

*( Third Revision )*

**SECTION 1  
GENERAL**

**1.1 Scope**

**1.1.1** This standard applies to general construction using hot rolled steel sections joined using riveting, bolting and welding. Specific provisions for bridges, chimneys, cranes, tanks, transmission line towers, bulk storage structures, tubular structures, cold formed light gauge steel sections, etc, are covered in separate standards.

**1.1.2** This standard gives only general guidance as regards the various loads to be considered in design. For the actual loads and load combinations to be used, reference may be made to IS 875 for dead, live, snow and wind loads and to IS 1893 (Part 1) for earthquake loads.

**1.1.3** Fabrication and erection requirements covered in this standard are general and the minimum necessary quality of material and workmanship consistent with assumptions in the design rules. The actual requirements may be further developed as per other standards or the project specification, the type of structure and the method of construction.

**1.1.4** For seismic design, recommendations pertaining to steel frames only are covered in this standard. For more detailed information on seismic design of other structural and non-structural components, reference should be made to IS 1893 (Part 1) and other special publications on the subject.

**1.2 References**

The standards listed in Annex A contain provisions which through reference in this text, constitute provisions of this standard. At the time of publication, the editions indicated were valid. All standards are subject to revision and parties to agreements based on this standard are encouraged to investigate the possibility of applying the most recent editions of the standards indicated in Annex A.

**1.3 Terminology**

For the purpose of this standard, the following definitions shall apply.

**1.3.1 Accidental Loads** — Loads due to explosion, impact of vehicles, or other rare loads for which the structure is considered to be vulnerable as per the user.

**1.3.2 Accompanying Load** — Live (imposed) load acting along with leading imposed load but causing lower actions and/or deflections.

**1.3.3 Action Effect or Load Effect** — The internal force, axial, shear, bending or twisting moment, due to external actions and temperature loads.

**1.3.4 Action** — The primary cause for stress or deformations in a structure such as dead, live, wind, seismic or temperature loads.

**1.3.5 Actual Length** — The length between centre-to-centre of intersection points, with supporting members or the cantilever length in the case of a free standing member.

**1.3.6 Beam** — A member subjected predominately to bending.

**1.3.7 Bearing Type Connection** — A connection made using bolts in 'snug-tight' condition, or rivets where the load is transferred by bearing of bolts or rivets against plate inside the bolt hole.

**1.3.8 Braced Member** — A member in which the relative transverse displacement is effectively prevented by bracing.

**1.3.9 Brittle Cladding** — Claddings, such as asbestos cement sheets which get damaged before undergoing considerable deformation.

**1.3.10 Buckling Load** — The load at which an element, a member or a structure as a whole, either collapses in service or buckles in a load test and develops excessive lateral (out of plane) deformation or instability.

**1.3.11 Buckling Strength or Resistance** — Force or moment, which a member can withstand without buckling.

**1.3.12 Built-up Section** — A member fabricated by interconnecting more than one element to form a compound section acting as a single member.

**1.3.13 Camber** — Intentionally introduced pre-curving (usually upwards) in a system, member or any portion

of a member with respect to its chord. Frequently, camber is introduced to compensate for deflections at a specific level of loads.

**1.3.14 Characteristic Load (Action)** — The value of specified load (action), above which not more than a specified percentage (usually 5 percent) of samples of corresponding load are expected to be encountered.

**1.3.15 Characteristic Yield/Ultimate Stress** — The minimum value of stress, below which not more than a specified percentage (usually 5 percent) of corresponding stresses of samples tested are expected to occur.

**1.3.16 Column** — A member in upright (vertical) position which supports a roof or floor system and predominantly subjected to compression.

**1.3.17 Compact Section** — A cross-section, which can develop plastic moment, but has inadequate plastic rotation capacity needed for formation of a plastic collapse mechanism of the member or structure.

**1.3.18 Constant Stress Range** — The amplitude between which the stress ranges under cyclic loading is constant during the life of the structure or a structural element.

**1.3.19 Corrosion** — An electrochemical process over the surface of steel, leading to oxidation of the metal.

**1.3.20 Crane Load** — Horizontal and vertical loads from cranes.

**1.3.21 Cumulative Fatigue** — Total damage due to fatigue loading of varying stress ranges.

**1.3.22 Cut-off Limit** — The stress range, corresponding to the particular detail, below which cyclic loading need not be considered in cumulative fatigue damage evaluation (corresponds to  $10^8$  numbers of cycles in most cases).

**1.3.23 Dead Loads** — The self-weights of all permanent constructions and installations including the self-weight of all walls, partitions, floors, roofs, and other permanent fixtures acting on a member.

**1.3.24 Deflection** — It is the deviation from the standard position of a member or structure.

**1.3.25 Design Life** — Time period for which a structure or a structural element is required to perform its function without damage.

**1.3.26 Design Load/Factored Load** — A load value obtained by multiplying the characteristic load with a load factor.

**1.3.27 Design Spectrum** — Frequency distribution of the stress ranges from all the nominal loading events during the design life (stress spectrum).

**1.3.28 Detail Category** — Designation given to a particular detail to indicate the *S-N* curve to be used in fatigue assessment.

**1.3.29 Discontinuity** — A sudden change in cross-section of a loaded member, causing a stress concentration at the location.

**1.3.30 Ductility** — It is the property of the material or a structure indicating the extent to which it can deform beyond the limit of yield deformation before failure or fracture. The ratio of ultimate to yield deformation is usually termed as ductility.

**1.3.31 Durability** — It is the ability of a material to resist deterioration over long periods of time.

**1.3.32 Earthquake Loads** — The inertia forces produced in a structure due to the ground movement during an earthquake.

**1.3.33 Edge Distance** — Distance from the centre of a fastener hole to the nearest edge of an element measured perpendicular to the direction of load transfer.

**1.3.34 Effective Lateral Restraint** — Restraint, that produces sufficient resistance to prevent deformation in the lateral direction.

**1.3.35 Effective Length** — Actual length of a member between points of effective restraint or effective restraint and free end, multiplied by a factor to take account of the end conditions in buckling strength calculations.

**1.3.36 Elastic Cladding** — Claddings, such as metal sheets, that can undergo considerable deformation without damage.

**1.3.37 Elastic Critical Moment** — The elastic moment, which initiates lateral-torsional buckling of a laterally unsupported beam.

**1.3.38 Elastic Design** — Design, which assumes elastic behaviour of materials throughout the service load range.

**1.3.39 Elastic Limit** — It is the stress below which the material regains its original size and shape when the load is removed. In steel design, it is taken as the yield stress.

**1.3.40 End Distance** — Distance from the centre of a fastener hole to the edge of an element measured parallel to the direction of load transfer.

**1.3.41 Erection Loads** — The actions (loads and deformations) experienced by the structure exclusively during erection.

**1.3.42 Erection Tolerance** — Amount of deviation related to the plumbness, alignment, and level of the

element as a whole in the erected position. The deviations are determined by considering the locations of the ends of the element.

**1.3.43 Exposed Surface Area to Mass Ratio** — The ratio of the surface area exposed to the fire (in mm<sup>2</sup>) to the mass of steel (in kg).

NOTE — In the case of members with fire protection material applied, the exposed surface area is to be taken as the internal surface area of the fire protection material.

**1.3.44 Fabrication Tolerance** — Amount of deviation allowed in the nominal dimensions and geometry in fabrication activities, such as cutting to length, finishing of ends, cutting of bevel angles, etc.

**1.3.45 Factor of Safety** — The factor by which the yield stress of the material of a member is divided to arrive at the permissible stress in the material.

**1.3.46 Fatigue** — Damage caused by repeated fluctuations of stress, leading to progressive cracking of a structural element.

**1.3.47 Fatigue Loading** — Set of nominal loading events, cyclic in nature, described by the distribution of the loads, their magnitudes and the number of applications in each nominal loading event.

**1.3.48 Fatigue Strength** — The stress range for a category of detail, depending upon the number of cycles it is required to withstand during design life.

**1.3.49 Fire Exposure Condition**

- a) *Three-sided fire exposure condition* — Steel member incorporated in or in contact with a concrete or masonry floor or wall (at least against one surface).

NOTES

1 Three-sided fire exposure condition is to be considered separately unless otherwise specified (see 16.10).

2 Members with more than one face in contact with a concrete or masonry floor or wall may be treated as three-sided fire exposure.

- b) *Four-sided fire exposure condition* — Steel member, which may be exposed to fire on all sides.

**1.3.50 Fire Protection System** — The fire protection material and its method of attachment to the steel member.

**1.3.51 Fire Resistance** — The ability of an element, component or structure, to fulfil for a stated period of time, the required stability, integrity, thermal insulation and/or other expected performance specified in a standard fire test.

**1.3.52 Fire Resistance Level** — The fire resistance grading period for a structural element or system, in minutes, which is required to be attained in the standard fire test.

**1.3.53 Flexural Stiffness** — Stiffness of a member against rotation as evaluated by the value of bending deformation moment required to cause a unit rotation while all other degrees of freedom of the joints of the member except the rotated one are assumed to be restrained.

**1.3.54 Friction Type Connection** — Connection effected by using pre-tensioned high strength bolts where shear force transfer is due to mobilisation of friction between the connected plates due to clamping force developed at the interface of connected plates by the bolt pre-tension.

**1.3.55 Gauge** — The spacing between adjacent parallel lines of fasteners, transverse to the direction of load/stress.

**1.3.56 Gravity Load** — Loads arising due to gravitational effects.

**1.3.57 Gusset Plate** — The plate to which the members intersecting at a joint are connected.

**1.3.58 High Shear** — High shear condition is caused when the actual shear due to factored load is greater than a certain fraction of design shear resistance (see 9.2.2).

**1.3.59 Imposed (Live) Load** — The load assumed to be produced by the intended use or occupancy including distributed, concentrated, impact, vibration and snow loads but excluding, wind, earthquake and temperature loads.

**1.3.60 Instability** — The phenomenon which disables an element, member or a structure to carry further load due to excessive deflection lateral to the direction of loading and vanishing stiffness.

**1.3.61 Lateral Restraint for a Beam** (see 1.3.34)

**1.3.62 Leading Imposed Load** — Imposed load causing higher action and/or deflection.

**1.3.63 Limit State** — Any limiting condition beyond which the structure ceases to fulfil its intended function (see also 1.3.86).

**1.3.64 Live Load** (see 1.3.59)

**1.3.65 Load** — An externally applied force or action (see also 1.3.4).

**1.3.66 Main Member** — A structural member, which is primarily responsible for carrying and distributing the applied load or action.

**1.3.67 Mill Tolerance** — Amount of variation allowed from the nominal dimensions and geometry, with respect to cross-sectional area, non-parallelism of

flanges, and out of straightness such as sweep or camber, in a product, as manufactured in a steel mill.

**1.3.68 Normal Stress** — Stress component acting normal to the face, plane or section.

**1.3.69 Partial Safety Factor** — The factor normally greater than unity by which either the loads (actions) are multiplied or the resistances are divided to obtain the design values.

**1.3.70 Period of Structural Adequacy under Fire** — The time ( $t$ ), in minutes, for the member to reach the limit state of structural inadequacy in a standard fire test.

**1.3.71 Permissible Stress** — When a structure is being designed by the working stress method, the maximum stress that is permitted to be experienced in elements, members or structures under the nominal/service load (action).

**1.3.72 Pitch** — The centre-to-centre distance between individual fasteners in a line, in the direction of load/stress.

**1.3.73 Plastic Collapse** — The failure stage at which sufficient number of plastic hinges have formed due to the loads (actions) in a structure leading to a failure mechanism.

**1.3.74 Plastic Design** — Design against the limit state of plastic collapse.

**1.3.75 Plastic Hinge** — A yielding zone with significant inelastic rotation, which forms in a member, when the plastic moment is reached at a section.

**1.3.76 Plastic Moment** — Moment capacity of a cross-section when the entire cross-section has yielded due to bending moment.

**1.3.77 Plastic Section** — Cross-section, which can develop a plastic hinge and sustain plastic moment over sufficient plastic rotation required for formation of plastic failure mechanism of the member or structure.

**1.3.78 Poisson's Ratio** — It is the absolute value of the ratio of lateral strain to longitudinal strain under uni-axial loading.

**1.3.79 Proof Stress** — The stress to which high strength friction grip (HSFG) bolts are pre-tensioned.

**1.3.80 Proof Testing** — The application of test loads to a structure, sub-structure, member or connection to ascertain the structural characteristics of only that specific unit.

**1.3.81 Prototype Testing** — Testing of structure, sub-structure, members or connections to ascertain the structural characteristics of that class of structures, sub-

structures, members or connections that are nominally identical (full scale) to the units tested.

**1.3.82 Prying Force** — Additional tensile force developed in a bolt as a result of the flexing of a connection component such as a beam end plate or leg of an angle.

**1.3.83 Rotation** — The change in angle at a joint between the original orientation of two linear member and their final position under loading.

**1.3.84 Secondary Member** — Member which is provided for overall stability and or for restraining the main members from buckling or similar modes of failure.

**1.3.85 Semi-compact Section** — Cross-section, which can attain the yield moment, but not the plastic moment before failure by plate buckling.

**1.3.86 Serviceability Limit State** — A limit state of acceptable service condition exceedence of which causes serviceability failure.

**1.3.87 Shear Force** — The inplane force at any transverse cross-section of a straight member of a column or beam.

**1.3.88 Shear Lag** — The in plane shear deformation effect by which concentrated forces tangential to the surface of a plate gets distributed over the entire section perpendicular to the load over a finite length of the plate along the direction of the load.

**1.3.89 Shear Stress** — The stress component acting parallel to a face, plane or cross-section.

**1.3.90 Slender Section** — Cross-section in which the elements buckle locally before reaching yield moment.

**1.3.91 Slenderness Ratio** — The ratio of the effective length of a member to the radius of gyration of the cross-section about the axis under consideration.

**1.3.92 Slip Resistance** — Limit shear that can be applied in a friction grip connection before slip occurs.

**1.3.93 S-N Curve** — The curve defining the relationship between the number of stress cycles to failure ( $N_{sc}$ ) at a constant stress range ( $S_c$ ), during fatigue loading of a structure.

**1.3.94 Snow Load** — Load on a structure due to the accumulation of snow and ice on surfaces such as roof.

**1.3.95 Snug Tight** — The tightness of a bolt achieved by a few impacts of an impact wrench or by the full effort of a person using a standard spanner.

**1.3.96 Stability Limit State** — A limit state corresponding to the loss of static equilibrium of a structure by excessive deflection transverse to the direction of predominant loads.

**1.3.97 Stickability** — The ability of the fire protection system to remain in place as the member deflects under load during a fire test.

**1.3.98 Stiffener** — An element used to retain or prevent the out-of-plane deformations of plates.

**1.3.99 Strain** — Deformation per unit length or unit angle.

**1.3.100 Strain Hardening** — The phenomenon of increase in stress with increase in strain beyond yielding.

**1.3.101 Strength** — Resistance to failure by yielding or buckling.

**1.3.102 Strength Limit State** — A limit state of collapse or loss of structural integrity.

**1.3.103 Stress** — The internal force per unit area of the original cross-section.

**1.3.104 Stress Analysis** — The analysis of the internal force and stress condition in an element, member or structure.

**1.3.105 Stress Cycle Counting** — Sum of individual stress cycles from stress history arrived at using any rational method.

**1.3.106 Stress Range** — Algebraic difference between two extremes of stresses in a cycle of loading.

**1.3.107 Stress Spectrum** — Histogram of stress cycles produced by a nominal loading event design spectrum, during design life.

**1.3.108 Structural Adequacy for Fire** — The ability of the member to carry the test load exposed to the standard fire test.

**1.3.109 Structural Analysis** — The analysis of stress, strain, and deflection characteristics of a structure.

**1.3.110 Strut** — A compression member, which may be oriented in any direction.

**1.3.111 Sway** — The lateral deflection of a frame.

**1.3.112 Sway Member** — A member in which the transverse displacement of one end, relative to the other is not effectively prevented.

**1.3.113 Tensile Stress** — The characteristic stress corresponding to rupture in tension, specified for the grade of steel in the appropriate Indian Standard, as listed in Table 1.

**1.3.114 Test Load** — The factored load, equivalent to a specified load combination appropriate for the type of test being performed.

**1.3.115 Transverse** — Direction along the stronger axes of the cross-section of the member.

**1.3.116 Ultimate Limit State** — The state which, if exceeded can cause collapse of a part or the whole of the structure.

**1.3.117 Ultimate Stress** (see 1.3.113)

**1.3.118 Wind Loads** — Load experienced by member or structure due to wind pressure acting on the surfaces.

**1.3.119 Yield Stress** — The characteristic stress of the material in tension before the elastic limit of the material is exceeded, as specified in the appropriate Indian Standard, as listed in Table 1.

## 1.4 Symbols

Symbols used in this standard shall have the following meanings with respect to the structure or member or condition, unless otherwise defined elsewhere in this Code.

$A$	— Area of cross-section
$A_c$	— Area at root of threads
$A_e$	— Effective cross-sectional area
$A_{ef}$	— Reduced effective flange area
$A_f$	— Total flange area
$A_g$	— Gross cross-sectional area
$A_{gf}$	— Gross cross-sectional area of flange
$A_{go}$	— Gross cross-sectional area of outstanding (not connected) leg of a member
$A_n$	— Net area of the total cross-section
$A_{nb}$	— Net tensile cross-sectional area of bolt
$A_{nc}$	— Net cross-sectional area of the connected leg of a member
$A_{nf}$	— Net cross-sectional area of each flange
$A_{no}$	— Net cross-sectional area of outstanding (not connected) leg of a member
$A_{pb}$	— Nominal bearing area of bolt on any plate
$A_q$	— Cross-sectional area of a bearing (load carrying) stiffener in contact with the flange
$A_s$	— Tensile stress area
$A_{sb}$	— Gross cross-sectional area of a bolt at the shank
$A_{tg}$	— Gross sectional area in tension from the centre of the hole to the toe of the angle section/channel section, etc (see 6.4) perpendicular to the line of force



$A_{tn}$	— Net sectional area in tension from the centre of the hole to the toe of the angle perpendicular to the line of force (see 6.4)		compression flange angles, plates or tongue plates to the neutral axis
$A_v$	— Shear area	$d_h$	— Diameter of a bolt/ rivet hole
$A_{vg}$	— Gross cross-sectional area in shear along the line of transmitted force (see 6.4)	$d_o$	— Nominal diameter of the pipe column or the dimensions of the column in the depth direction of the base plate
$A_{vn}$	— Net cross-sectional area in shear along the line of transmitted force (see 6.4)	$d_p$	— Panel zone depth in the beam-column junction
$a, b$	— Larger and smaller projection of the slab base beyond the rectangle circumscribing the column, respectively (see 7.4)	$E$	— Modulus of elasticity for steel
$a_o$	— Peak acceleration	$E(T)$	— Modulus of elasticity of steel at $T^\circ\text{C}$
$a_1$	— Unsupported length of individual elements being laced between lacing points	$E(20)$	— Modulus of elasticity of steel at $20^\circ\text{C}$
$B$	— Length of side of cap or base plate of a column	$E_p$	— Modulus of elasticity of the panel material
$b$	— Outstand/width of the element	$F_{cdw}$	— Buckling strength of un-stiffened beam web under concentrated load
$b_1$	— Stiff bearing length, Stiffener bearing length	$F_d$	— Factored design load
$b_e$	— Effective width of flange between pair of bolts	$F_n$	— Normal force
$b_f$	— Width of the flange	$F_o$	— Minimum proof pretension in high strength friction grip bolts.
$b_i$	— Width of flange as an internal element	$F_{psd}$	— Bearing capacity of load carrying stiffener
$b_o$	— Width of flange outstand	$F_q$	— Stiffener force
$b_p$	— Panel zone width between column flanges at beam-column junction	$F_{qd}$	— Stiffener buckling resistance
$b_s$	— Shear lag distance	$F_{test}$	— Test load
$b_t$	— Width of tension field	$F_{test, a}$	— Load for acceptance test
$b_w$	— Width of outstanding leg	$F_{test, Min}$	— Minimum test load from the test to failure
$C$	— Centre-to-centre longitudinal distance of battens	$F_{test, R}$	— Test load resistance
$C_m$	— Coefficient of thermal expansion	$F_{test, S}$	— Strength test load
$C_{my}, C_{mz}$	— Moment amplification factor about respective axes	$F_w$	— Design capacity of the web in bearing
$c$	— Spacing of transverse stiffener	$F_x$	— External load, force or reaction
$c_b$	— Moment amplification factor for braced member	$F_{xd}$	— Buckling resistance of load carrying web stiffener
$c_m$	— Moment reduction factor for lateral torsional buckling strength calculation	$f$	— Actual normal stress range for the detail category
$c_s$	— Moment amplification factor for sway frame	$f_1$	— Frequency for a simply supported one way system
$D$	— Overall depth/diameter of the cross-section	$f_2$	— Frequency of floor supported on steel girder perpendicular to the joist
$d$	— Depth of web, Nominal diameter	$f_a$	— Calculated stress due to axial force at service load
$d_2$	— Twice the clear distance from the	$f_{abc}$	— Permissible bending stress in compression at service load
		$f_{ac}$	— Permissible compressive stress at service load
		$f_{abt}$	— Permissible bending stress in tension at service load
		$f_{apb}$	— Permissible bearing stress of the bolt at service load
		$f_{asb}$	— Permissible stress of the bolt in shear at service load

$f_{at}$	— Permissible tensile stress at service load	$f_v$	— Applied shear stress in the panel designed utilizing tension field action
$f_{atb}$	— Permissible tensile stress of the bolt at service load	$f_w$	— Actual stress of weld at service load
$f_{aw}$	— Permissible stress of the weld at service load	$f_{wd}$	— Design stress of weld at service load
$f_b$	— Actual bending stress at service load	$f_{wn}$	— Nominal strength of fillet weld
$f_{bc}$	— Actual bending stress in compression at service load	$f_x$	— Maximum longitudinal stress under combined axial force and bending
$f_{bd}$	— Design bending compressive stress corresponding to lateral buckling	$f_y$	— Characteristic yield stress
$f_{br}$	— Actual bearing stress due to bending at service load	$f_y(T)$	— Yield stress of steel at $T$ °C
$f_{bt}$	— Actual bending stress in tension at service load	$f_y(20)$	— Yield stress of steel at 20°C
$f_{bs}$	— Permissible bending stress in column base at service load	$f_{yb}$	— Characteristic yield stress of bolt
$f_c$	— Actual axial compressive stress at service load	$f_{yf}$	— Characteristic yield stress of flange
$f_{cc}$	— Elastic buckling stress of a column, Euler buckling stress	$f_{ym}$	— Average yield stress as obtained from test
$f_{cd}$	— Design compressive stress	$f_{yp}$	— Characteristic yield stress of connected plate
$f_{cr, b}$	— Extreme fibre compressive stress corresponding elastic lateral buckling moment	$f_{yq}$	— Characteristic yield stress of stiffener material
$f_e$	— Equivalent stress at service load	$f_{yw}$	— Characteristic yield stress of the web material
$f_f$	— Fatigue stress range corresponding to $5 \times 10^6$ cycles of loading	$G$	— Modulus of rigidity for steel
$f_{feq}$	— Equivalent constant amplitude stress	$g$	— Gauge length between centre of the holes perpendicular to the load direction, acceleration due to gravity
$f_{fd}$	— Design normal fatigue strength	$h$	— Depth of the section
$f_{f, Max}$	— Highest normal stress range	$h_b$	— Total height from the base to the floor level concerned
$f_{fn}$	— Normal fatigue stress range	$h_c$	— Height of the column
$f_{nw}$	— Normal stress in weld at service load	$h_e$	— Effective thickness
$f_o$	— Proof stress	$h_f$	— Centre-to-centre distance of flanges
$f_p$	— Actual bearing stress at service load	$h_i$	— Thickness of fire protection material
$f_{pb}$	— Actual bearing stress in bending at service load	$h_l$	— Height of the lip
$f_{psd}$	— Bearing strength of the stiffeners	$h_s$	— Storey height
$f_r$	— Frequency	$h_y$	— Distance between shear centre of the two flanges of a cross-section
$f_{sb}$	— Actual shear stress in bolt at service load	$I$	— Moment of inertia of the member about an axis perpendicular to the plane of the frame
$f_t$	— Actual tensile stress at service load	$I_{fc}$	— Moment of inertia of the compression flange of the beam about the axis parallel to the web
$f_{tb}$	— Actual tensile stress of the bolt at service load	$I_{ft}$	— Moment of inertia of the tension flange of the beam about minor axis
$f_u$	— Characteristic ultimate tensile stress	$I_q$	— Moment of inertia of a pair of stiffener about the centre of the web, or a single stiffener about the face of the web
$f_{ub}$	— Characteristic ultimate tensile stress of the bolt	$I_s$	— Second moment of inertia
$f_{um}$	— Average ultimate stress of the material as obtained from test	$I_{so}$	— Second moment of inertia of the stiffener about the face of the element perpendicular to the web
$f_{up}$	— Characteristic ultimate tensile stress of the connected plate		

$I_T$	— Transformed moment of inertia of the one way system (in terms of equivalent steel, assuming the concrete flange of width equal to the spacing of the beam to be effective)	$l$	— Centre-to-centre length of the supporting member
$I_t$	— St. Venant's torsion constant	$l_c$	— Distance between prying force and bolt centre line
$I_w$	— Warping constant	$l_g$	— Grip length of bolts in a connection
$I_y$	— Moment of inertia about the minor axis of the cross-section	$l_j$	— Length of the joint
$I_z$	— Moment of inertia about the major axis of the cross-section	$l_s$	— Length between points of lateral support to the compression flange in a beam
$K_b$	— Effective stiffness of the beam and column	$l_v$	— Distance from bolt centre line to the toe of fillet weld or to half the root radius for a rolled section
$K_h$	— Reduction factor to account for the high strength friction grip connection bolts in over sized and slotted holes	$l_w$	— Length of weld
$KL$	— Effective length of the member	$M$	— Bending moment
$KL/r$	— Appropriate effective slenderness ratio of the section	$M_a$	— Applied bending moment
$KL/r_y$	— Effective slenderness ratio of the section about the minor axis of the section	$M_{cr}$	— Elastic critical moment corresponding to lateral torsional buckling of the beam
$KL/r_z$	— Effective slenderness ratio of the section about the major axis of the section	$M_d$	— Design flexural strength
$\left(\frac{KL}{r}\right)_o$	— Actual maximum effective slenderness ratio of the laced column	$M_{dv}$	— Moment capacity of the section under high shear
$\left(\frac{KL}{r}\right)_c$	— Effective slenderness ratio of the laced column accounting for shear deformation	$M_{dy}$	— Design bending strength about the minor axis of the cross-section
$K_v$	— Shear buckling co-efficient	$M_{dz}$	— Design bending strength about the major axis of the cross-section
$K_w$	— Warping restraint factor	$M_{eff}$	— Reduced effective moment
$k$	— Regression coefficient	$M_{fr}$	— Reduced plastic moment capacity of the flange plate
$k_{sm}$	— Exposed surface area to mass ratio	$M_{fd}$	— Design plastic resistance of the flange alone
$L$	— Actual length, unsupported length, Length centre-to-centre distance of the intersecting members, Cantilever length	$M_{nd}$	— Design bending strength under combined axial force and uniaxial moment
$L_c$	— Length of end connection in bolted and welded members, taken as the distance between outermost fasteners in the end connection, or the length of the end weld, measured along the length of the member	$M_{ndy}, M_{ndz}$	— Design bending strength under combined axial force and the respective uniaxial moment acting alone
$L_{LT}$	— Effective length for lateral torsional buckling	$M_p$	— Plastic moment capacity of the section
$L_m$	— Maximum distance from the restraint to the compression flange at the plastic hinge to an adjacent restraint (limiting distance)	$M_{pb}$	— Moment in the beam at the intersection of the beam and column centre lines
$L_o$	— Length between points of zero moment (inflection) in the span	$M_{pc}$	— Moments in the column above and below the beam surfaces
		$M_{pd}$	— Plastic design strength
		$M_{pdf}$	— Plastic design strength of flanges only
		$M_q$	— Applied moment on the stiffener
		$M_s$	— Moment at service (working) load
		$M_{tf}$	— Moment resistance of tension flange
		$M_y$	— Factored applied moment about the minor axis of the cross-section

$M_{yq}$	— Moment capacity of the stiffener based on its elastic modulus	$R_i$	— Net shear in bolt group at bolt “ $i$ ”
$M_z$	— Factored applied moment about the major axis of the cross-section	$R_r$	— Response reduction factor
$N$	— Number of parallel planes of battens	$R_{if}$	— Flange shear resistance
$N_d$	— Design strength in tension or in compression	$R_u$	— Ultimate strength of the member at room temperature
$N_f$	— Axial force in the flange	$r$	— Appropriate radius of gyration
$N_{sc}$	— Number of stress cycles	$r_1$	— Minimum radius of gyration of the individual element being laced together
$n$	— Number of bolts in the bolt group/critical section	$r_f$	— Ratio of the design action on the member under fire to the design capacity
$n_e$	— Number of effective interfaces offering frictional resistance to slip	$r_{vv}$	— Radius of gyration about the minor axis ( $v-v$ ) of angle section.
$n_n$	— Number of shear planes with the threads intercepting the shear plane in the bolted connection	$r_y$	— Radius of gyration about the minor axis
$n_s$	— Number of shear planes without threads intercepting the shear plane in the bolted connection	$r_z$	— Radius of gyration about the major axis
$P$	— Factored applied axial force	$S$	— Minimum transverse distance between the centroid of the rivet or bolt group or weld group
$P_{cc}$	— Elastic buckling load	$S_c$	— Constant stress range
$P_d$	— Design axial compressive strength	$S_d$	— Design strength
$P_{dy}, P_{dz}$	— Design compression strength as governed by flexural buckling about the respective axis	$S_o$	— Original cross-sectional area of the test specimen
$P_e$	— Elastic Euler buckling load	$S_p$	— Spring stiffness
$P_{Min}$	— Minimum required strength for each flange splice	$S_u$	— Ultimate strength
$P_r$	— Required compressive strength	$s_c$	— Anchorage length of tension field along the compression flange
$P_s$	— Actual compression at service load	$s_t$	— Anchorage length of tension field along the tension flange
$P_y$	— Yield strength of the cross-section under axial compression	$s_a$	— Actual stiffener spacing
$p$	— Pitch length between centres of holes parallel to the direction of the load	$T$	— Temperature in degree Celsius; Factored tension
$p_s$	— Staggered pitch length along the direction of the load between lines of the bolt holes ( <i>see</i> Fig. 5)	$T_b$	— Applied tension in bolt
$Q$	— Prying force	$T_{cf}$	— Thickness of compression flange
$Q_a$	— Accidental load (Action)	$T_d$	— Design strength under axial tension
$Q_c$	— Characteristic loads (Action)	$T_{dg}$	— Yielding strength of gross section under axial tension
$Q_d$	— Design load (Action)	$T_{dn}$	— Rupture strength of net section under axial tension
$Q_p$	— Permanent loads (Action)	$T_{db}$	— Design strength of bolt under axial tension; Block shear strength at end connection
$Q_v$	— Variable loads (Action)	$T_e$	— Externally applied tension
$q$	— Shear stress at service load	$T_f$	— Factored tension force of friction type bolt
$R$	— Ratio of the mean compressive stress in the web (equal to stress at mid depth) to yield stress of the web; reaction of the beam at support	$T_l$	— Limiting temperature of the steel
$R_d$	— Design strength of the member at room temperature	$T_{nb}$	— Nominal strength of bolt under axial tension
		$T_{nd}$	— Design tension capacity

$T_{ndf}$	— Design tension capacity of friction type bolt		member with respect to extreme compression fibre
$T_{nf}$	— Nominal tensile strength of friction type bolt	$Z_{ct}$	— Elastic section modulus of the member with respect to extreme tension fibre
$T_s$	— Actual tension under service load	$Z_p$	— Plastic section modulus
$t$	— Thickness of element/angle, time in minutes	$Z_v$	— Contribution to the plastic section modulus of the total shear area of the cross-section
$t_f$	— Thickness of flange	$y_g$	— Distance between point of application of the load and shear centre of the cross-section
$t_p$	— Thickness of plate	$y_s$	— Co-ordinate of the shear centre in respect to centroid
$t_{pk}$	— Thickness of packing	$\alpha$	— Imperfection factor for buckling strength in columns and beams
$t_q$	— Thickness of stiffener	$\alpha_t$	— Coefficient of thermal expansion
$t_s$	— Thickness of base slab	$\beta_M$	— Ratio of smaller to the larger bending moment at the ends of a beam column
$t_t$	— Effective throat thickness of welds	$\beta_{My}, \beta_{Mz}$	— Equivalent uniform moment factor for flexural buckling for y-y and z-z axes respectively
$t_w$	— Thickness of web,	$\beta_{MLT}$	— Equivalent uniform moment factor for lateral torsional buckling
$V$	— Factored applied shear force	$\chi$	— Strength reduction factor to account for buckling under compression
$V_b$	— Shear in batten plate	$\chi_{m1}$	— Strength reduction factor, $\chi$ , at $f_{ym}$
$V_{br}$	— Factored frictional shear force in friction type connection	$\chi_{LT}$	— Strength reduction factor to account for lateral torsional buckling of beams
$V_{cr}$	— Critical shear strength corresponding to web buckling	$\delta$	— Storey deflection
$V_d$	— Design shear strength	$\delta_L$	— Horizontal deflection of the bottom of storey due to combined gravity and notional load
$V_{db}$	— Block shear strength	$\delta_p$	— Load amplification factor
$V_{nb}$	— Nominal shear strength of bolt	$\delta_U$	— Horizontal deflection of the top of storey due to combined gravity and notional load
$V_{nbf}$	— Bearing capacity of bolt for friction type connection	$\phi$	— Inclination of the tension field stress in web
$V_p$	— Plastic shear resistance under pure shear	$\gamma$	— Unit weight of steel
$V_n$	— Nominal shear strength	$\gamma_f$	— Partial safety factor for load
$V_{npb}$	— Nominal bearing strength of bolt	$\gamma_m$	— Partial safety factor for material
$V_{nsb}$	— Nominal shear capacity of a bolt	$\gamma_{m0}$	— Partial safety factor against yield stress and buckling
$V_{nsf}$	— Nominal shear capacity of bolt as governed by slip in friction type connection	$\gamma_{m1}$	— Partial safety factor against ultimate stress
$V_s$	— Transverse shear at service load	$\gamma_{m2}$	— Partial safety factor for bolted connection with bearing type bolts
$V_{sb}$	— Factored shear force in the bolt	$\gamma_{mf}$	— Partial safety factor for bolted connection with High Strength Friction Grip bolts
$V_{sd}$	— Design shear capacity		
$V_{sdf}$	— Design shear strength in friction type bolt		
$V_{sf}$	— Factored design shear force of friction bolts		
$V_t$	— Applied transverse shear		
$V_{tf}$	— Shear resistance in tension field		
$W$	— Total load		
$w$	— Uniform pressure from below on the slab base due to axial compression under the factored load		
$w_{tf}$	— Width of tension field		
$x_t$	— Torsional index		
$Z_e$	— Elastic section modulus		
$Z_{ec}$	— Elastic section modulus of the		

$\gamma_{fit}$	— Partial safety factor for fatigue load
$\gamma_{mft}$	— Partial safety factor for fatigue strength
$\gamma_{mv}$	— Partial safety factor against shear failure
$\gamma_{mw}$	— Partial safety factor for strength of weld
$\epsilon$	— Yield stress ratio $(250 / f_y)^{1/2}$
$\lambda$	— Non-dimensional slenderness ratio = $\sqrt{f_y (KL/r)^2 / \pi^2 E} = \sqrt{f_y / f_{cc}} = \sqrt{P_y / P_{cc}}$
$\lambda_{cr}$	— Elastic buckling load factor
$\lambda_e$	— Equivalent slenderness ratio
$\lambda_{LT}$	— Non-dimensional slenderness ratio in lateral bending
$\lambda_{scr}$	— Elastic buckling load factor of each storey
$\mu$	— Poisson's ratio
$\mu_c$	— Correction factor
$\mu_f$	— Coefficient of friction (slip factor)
$\mu_r$	— Capacity reduction factor
$\theta$	— Ratio of the rotation at the hinge point to the relative elastic rotation of the far end of the beam segment containing plastic hinge
$\rho$	— Unit mass of steel
$\tau$	— Actual shear stress range for the detail category
$\tau_b$	— Buckling shear stress
$\tau_{ab}$	— Permissible shear stress at the service load
$\tau_{cr,e}$	— Elastic critical shear stress
$\tau_f$	— Fatigue shear stress range
$\tau_{f,Max}$	— Highest shear stress range
$\tau_{fd}$	— Design shear fatigue strength
$\tau_{fn}$	— Fatigue shear stress range at $N_{sc}$ cycle for the detail category
$\tau_v$	— Actual shear stress at service load
$\psi$	— Ratio of the moments at the ends of the laterally unsupported length of a beam
$\Gamma$	— Frame buckling load factor

NOTE — The subscripts  $y$ ,  $z$  denote the  $y$ - $y$  and  $z$ - $z$  axes of the section, respectively. For symmetrical sections,  $y$ - $y$  denotes the minor principal axis whilst  $z$ - $z$  denotes the major principal axis (see 1.8).

## 1.5 Units

For the purpose of design calculations the following units are recommended:

- Forces and loads, in kN, kN/m, kN/m<sup>2</sup>;
- Unit mass, in kg/m<sup>3</sup>;
- Unit weight, in kN/m<sup>3</sup>;
- Stresses and strengths, in N/mm<sup>2</sup> (MN/m<sup>2</sup> or MPa); and
- Moments (bending, etc), in kNm.

For conversion of one system of units to another system, IS 786 (Supplement) may be referred.

## 1.6 Standard Dimensions, Form and Weight

The dimensions, form, weight, tolerances of all rolled shapes, all rivets, bolts, nuts, studs, and welds and other members used in any steel structure shall conform to IS 808 and IS 1852, wherever applicable.

## 1.7 Plans and Drawings

1.7.1 Plans, drawings and stress sheet shall be prepared according to IS 8000 (Parts 1 to 4), IS 8976 and IS 962.

### 1.7.1.1 Plans

The plans (design drawings) shall show the sizes, sections, and the relative locations of the various members. Floor levels, column centres, and offsets shall be dimensioned. Plans shall be drawn to a scale large enough to convey the information adequately. Plans shall indicate the type of construction to be employed; and shall be supplemented by such data on the assumed loads, shears, moments and axial forces to be resisted by all members and their connections, as may be required for the proper preparation of shop drawings. Any special precaution to be taken in the erection of structure, from the design consideration shall also be indicated in the drawing.

### 1.7.1.2 Shop drawings

Shop drawings, giving complete information necessary for the fabrication of the component parts of the structure including the location, type, size, length and detail of all welds and fasteners shall be prepared in advance of the actual fabrication. They shall clearly distinguish between shop and field rivets, bolts and welds. For additional information to be included on drawings for designs based on the use of welding, reference shall be made to appropriate Indian Standards. Shop drawings shall be made in conformity with IS 962. A marking diagram allotting distinct identification marks to each separate part of steel work shall be prepared. The diagram shall be sufficient to ensure convenient assembly and erection at site.

1.7.2 Symbols used for welding on plans and shop drawings shall be according to IS 813.

## 1.8 Convention for Member Axes

Unless otherwise specified convention used for member axes is as follows (*see* Fig. 1):

- a)  $x-x$  along the member.
- b)  $y-y$  an axis of the cross-section.
  - 1) perpendicular to the flanges, and
  - 2) perpendicular to the smaller leg in an angle section.
- c)  $z-z$  an axis of the cross-section.
  - 1) axis parallel to flanges, and
  - 2) axis parallel to smaller leg in angle section.
- d)  $u-u$  major axis (when it does not coincide with  $z-z$  axis).
- e)  $v-v$  minor axis (when it does not coincide with  $y-y$  axis).

## SECTION 2 MATERIALS

### 2.1 General

The material properties given in this section are nominal values, to be accepted as characteristic values in design calculations.

### 2.2 Structural Steel

**2.2.1** The provisions in this section are applicable to the steels commonly used in steel construction, namely, structural mild steel and high tensile structural steel.

**2.2.2** All the structural steel used in general construction, coming under the purview of this standard shall before fabrication conform to IS 2062.

**2.2.3** Structural steel other than those specified in 2.2.2 may also be used provided that the permissible stresses and other design provisions are suitably modified and the steel is also suitable for the type of fabrication adopted.

**2.2.3.1** Steel that is not supported by mill test result may be used only in unimportant members and details, where their properties such as ductility and weldability would not affect the performance requirements of the members and the structure as a whole.

However, such steels may be used in structural system after confirming their quality by carrying out appropriate tests in accordance with the method specified in IS 1608.

### 2.2.4 Properties

The properties of structural steel for use in design, may be taken as given in 2.2.4.1 and 2.2.4.2.

**2.2.4.1** Physical properties of structural steel irrespective of its grade may be taken as:

- a) Unit mass of steel,  $\rho = 7\,850\text{ kg/m}^3$
- b) Modulus of elasticity,  $E = 2.0 \times 10^5\text{ N/mm}^2$  (MPa)
- c) Poisson ratio,  $\mu = 0.3$
- d) Modulus of rigidity,  $G = 0.769 \times 10^5\text{ N/mm}^2$  (MPa)
- e) Co-efficient of thermal expansion  $\alpha_t = 12 \times 10^{-6}/^\circ\text{C}$

### 2.2.4.2 Mechanical properties of structural steel

The principal mechanical properties of the structural steel important in design are the yield stress,  $f_y$ ; the tensile or ultimate stress,  $f_u$ ; the maximum percent elongation on a standard gauge length and notch toughness. Except for notch toughness, the other properties are determined by conducting tensile tests on samples cut from the plates, sections, etc, in accordance with IS 1608. Commonly used properties for the common steel products of different specifications are summarized in Table 1.

### 2.3 Rivets

**2.3.1** Rivets shall be manufactured from steel

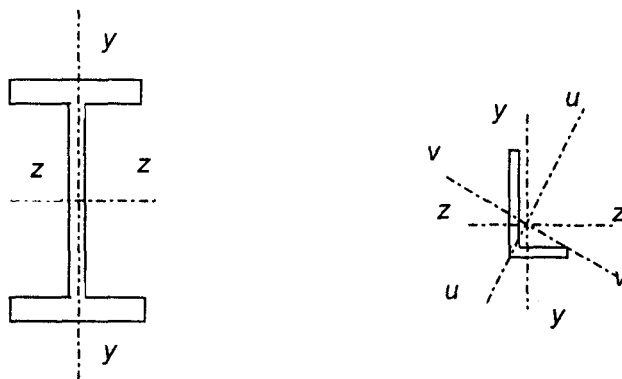


FIG. 1 AXES OF MEMBERS

Table 1 Tensile Properties of Structural Steel Products

(Clauses 1.3.113, 1.3.119 and 2.2.4.2)

SI No.	Indian Standard	Grade/Classification	Properties									
			Yield Stress MPa, <i>Min</i>	Ultimate Tensile Stress MPa, <i>Min</i>	Elongation, Percent, <i>Min</i>							
(1)	(2)	(3)	(4)	(5)	(6)							
i)	IS 513	O	—	—	—							
		D	280	270-410	28							
		DD	250	270-370	32							
		EDD	220	270-350	35							
ii)	IS 814	Ex40xx	330	410-540	16							
		Ex41xx	330	410-540	20							
		Ex42xx	330	410-540	22							
		Ex43xx	330	410-540	24							
		Ex44xx	330	410-540	24							
		Ex50xx	360	510-610	16							
		Ex51xx	360	510-610	18							
		Ex52xx	360	510-610	18							
		Ex53xx	360	510-610	20							
		Ex54xx	360	510-610	20							
iii)	IS 1079	O	—	—	—							
		D	—	240-400	25							
		DD	—	260-390	28							
		EDD	—	260-380	32							
iv)	IS 1367 (Part 3)	3.6	—	330	25							
		4.6	—	400	22							
		4.8	—	420	—							
		5.6	—	500	20							
		5.8	—	520	—							
		6.8	—	600	—							
		8.8 ( $d \leq 16$ mm)	640 <sup>1)</sup>	800	12							
		8.8 ( $d > 16$ mm)	660 <sup>1)</sup>	830	12							
		9.8	720 <sup>1)</sup>	900	10							
		10.9	940 <sup>1)</sup>	1 040	9							
12.9	1 100 <sup>1)</sup>	1 220	8									
v)	IS 1875	1	200	370	26							
		1A	220	410	25							
		2	230	430	24							
		2A	250	460	22							
		3	270	490	21							
		3A	280	540	20							
		4	320	620	15							
		5	350	710	13							
6	370	740	10									
vi)	IS 1990	S <sub>r</sub> 37	$d$ or $t$		360-440	26						
			$\leq 20$	$> 20$								
		S <sub>r</sub> 42	$\leq 20$	$> 20$	410-500	23						
			220	200								
			250	240								
vii)	IS 2002	1 2 3	$t$					$t$			$t$	
			$\leq 16$	$>16$ and $\leq 40$	$>40$ and $\leq 60$	$>60$ and $\leq 100$	$>100$ and $\leq 350$	$\leq 60$	$>60$ and $\leq 100$	$>100$ and $\leq 350$	$\leq 60$	$>60$ and $\leq 350$
			235	225	215	200	185	360-480	360-480	350-480	24	23
			265	255	245	215	200	410-530	410-530	400-530	22	21
			290	285	280	255	230	460-580	450-570	440-570	21	20



Table 1 (Concluded)

SI No.	Indian Standard	Grade/Classification	Properties				
			Yield Stress MPa, <i>Min</i>	Ultimate Tensile Stress MPa, <i>Min</i>	Elongation, Percent, <i>Min</i>		
(1)	(2)	(3)	(4)			(5)	(6)
			<i>d or t</i>				
			< 20	20-40	> 40		
viii)	IS 2062	E 165 (Fe 290)	165	165	165	290	23
		E 250 (Fe 410 W) A	250	240	230	410	23
		E 250 (Fe 410 W) B	250	240	230	410	23
		E 250 (Fe 410 W) C	250	240	230	410	23
		E 300 (Fe 440)	300	290	280	440	22
		E 350 (Fe 490)	350	330	320	490	22
		E 410 (Fe 540)	410	390	380	540	20
		E 450 (Fe 570) D	450	430	420	570	20
		E 450 (Fe 590) E	450	430	420	590	20
			<i>d or t</i>				
			≤ 25	> 25 and ≤ 50			
ix)	IS 3039	I	230	220		400-490	22
		II	235	235		400-490	22
		III	235	235		400-490	22
x)	IS 6240	Grade 1		240		350-450	25
		Grade 2		245		360-450	34
xi)	IS 7557	Annealed Condition		160		330-410	30
		As-Drawn Condition		190		410-490	20
xii)	IS 9295	HFC 210/CDS 210/ERW210		210		330	20
		HFC 240/CDS 240/ERW240		240		410	18
		HFC 310/CDS 310/ERW310		310		450	15
xiii)	IS 10748	1		170		290	30
		2		210		330	28
		3		240		410	25
		4		275		430	20
		5		310		490	15

## NOTES

1 Percent of elongation shall be taken over the gauge length  $5.65 \sqrt{S_0}$ , where  $S_0$  = Original cross-sectional area of the test specimen.

2 Abbreviations: O = Ordinary, D = Drawing, DD = Deep Drawing, EDD = Extra Deep Drawing.

1) Stress at 0.2 percent non-proportional elongation, *Min*.

conforming to IS 7557. They may also be manufactured from steel conforming to IS 2062 provided that the steel meets the requirements given in IS 1148.

**2.3.2 Rivets** shall conform to IS 1929 and IS 2155 as appropriate.

### 2.3.3 High Tensile Steel Rivets

High tensile steel rivets, shall be manufactured from steel conforming to IS 1149.

## 2.4 Bolts, Nuts and Washers

Bolts, nuts and washers shall conform as appropriate to IS 1363 (Parts 1 to 3), IS 1364 (Parts 1 to 5), IS 1367 (Parts 1 to 20), IS 3640, IS 3757, IS 4000, IS 5369, IS 5370, IS 5372, IS 5374, IS 5624, IS 6610, IS 6623, IS 6639, and IS 6649. The recommendations in IS 4000 shall be followed.

## 2.5 Steel Casting

Steel casting shall conform to IS 1030 or IS 2708.

## 2.6 Welding Consumable

**2.6.1 Covered electrodes** shall conform to IS 814 or IS 1395, as appropriate.

**2.6.2 Filler rods and wires for gas welding** shall conform to IS 1278.

**2.6.3 The supply of solid filler wires for submerged arc welding of structural steels** shall conform to IS 1387.

**2.6.4 The bare wire electrodes for submerged arc welding** shall conform to IS 7280. The combination of wire and flux shall satisfy the requirements of IS 3613.

**2.6.5 Filler rods and bare electrodes for gas shielded metal arc welding** shall conform to IS 6419 and IS 6560, as appropriate.

## 2.7 Other Materials

Other materials used in association with structural steel work shall conform to appropriate Indian Standards.

## SECTION 3 GENERAL DESIGN REQUIREMENTS

### 3.1 Basis for Design

#### 3.1.1 Design Objective

The objective of design is the achievement of an acceptable probability that structures will perform satisfactorily for the intended purpose during the design life. With an appropriate degree of safety, they should sustain all the loads and deformations, during

construction and use and have adequate resistance to certain expected accidental loads and fire. Structure should be stable and have alternate load paths to prevent disproportionate overall collapse under accidental loading.

#### 3.1.2 Methods of Design

**3.1.2.1** Structure and its elements shall normally, be designed by the limit state method. Account should be taken of accepted theories, experimental information and experience and the need to design for durability. Calculations alone may not produce safe, serviceable and durable structures. Suitable materials, quality control, adequate detailing and good supervision are equally important.

**3.1.2.2** Where the limit states method cannot be conveniently adopted; the working stress design (*see* Section 11) may be used.

#### 3.1.3 Design Process

Structural design, including design for durability, construction and use should be considered as a whole. The realization of design objectives requires compliance with clearly defined standards for materials, fabrication, erection and in-service maintenance.

## 3.2 Loads and Forces

**3.2.1** For the purpose of designing any element, member or a structure, the following loads (actions) and their effects shall be taken into account, where applicable, with partial safety factors and combinations (*see* 5.3.3):

- a) Dead loads;
- b) Imposed loads (live load, crane load, snow load, dust load, wave load, earth pressures, etc);
- c) Wind loads;
- d) Earthquake loads;
- e) Erection loads;
- f) Accidental loads such as those due to blast, impact of vehicles, etc; and
- g) Secondary effects due to contraction or expansion resulting from temperature changes, differential settlements of the structure as a whole or of its components, eccentric connections, rigidity of joints differing from design assumptions.

**3.2.1.1** Dead loads should be assumed in design as specified in IS 875 (Part 1).

**3.2.1.2** Imposed loads for different types of occupancy and function of structures shall be taken as recommended in IS 875 (Part 2). Imposed loads arising

from equipment, such as cranes and machines should be assumed in design as per manufacturers/suppliers data (*see* 3.5.4). Snow load shall be taken as per IS 875 (Part 4).

**3.2.1.3** Wind loads on structures shall be taken as per the recommendations of IS 875 (Part 3).

**3.2.1.4** Earthquake loads shall be assumed as per the recommendations of IS 1893 (Part 1).

**3.2.1.5** The erection loads and temperature effects shall be considered as specified in 3.3 and 3.4 respectively.

### 3.3 Erection Loads

All loads required to be carried by the structure or any part of it due to storage or positioning of construction material and erection equipment, including all loads due to operation of such equipment shall be considered as erection loads. Proper provision shall be made, including temporary bracings, to take care of all stresses developed during erection. Dead load, wind load and also such parts of the live load as would be imposed on the structure during the period of erection shall be taken as acting together with the erection loads. The structure as a whole and all parts of the structure in conjunction with the temporary bracings shall be capable of sustaining these loads during erection.

### 3.4 Temperature Effects

**3.4.1** Expansion and contraction due to changes in temperature of the members and elements of a structure shall be considered and adequate provision made for such effect.

**3.4.2** The temperature range varies for different localities and under different diurnal and seasonal conditions. The absolute maximum and minimum temperatures, which may be expected in different localities of the country, may be obtained from the Indian Metrological Department and used in assessing the maximum variations of temperature for which provision for expansion and contraction has to be made in the structure.

**3.4.3** The range of variation in temperature of the building materials may be appreciably greater or lesser than the variation of air temperature and is influenced by the condition of exposure and the rate at which the materials composing the structure absorb or radiate heat. This difference in temperature variations of the material and air shall be given due consideration. The effect of differential temperature within an element or member, due to part exposure to direct sunlight shall also be considered.

**3.4.4** The co-efficient of thermal expansion for steel is as given in 2.2.4.1(e).

### 3.5 Load Combinations

**3.5.1** Load combinations for design purposes shall be those that produce maximum forces and effects and consequently maximum stresses and deformations. The following combination of loads with appropriate partial safety factors (*see* Table 4) may be considered.

- a) Dead load + imposed load,
- b) Dead load + imposed load + wind or earthquake load,
- c) Dead load + wind or earthquake load, and
- d) Dead load + erection load.

NOTE — In the case of structures supporting cranes, imposed loads shall include the crane effects as given in 3.5.4.

**3.5.2** Wind load and earthquake loads shall not be assumed to act simultaneously. The effect of each shall be considered separately.

**3.5.3** The effect of cranes to be considered under imposed loads shall include the vertical loads, eccentricity effects induced by the vertical loads, impact factors, lateral (surge) and longitudinal (horizontal) thrusts, not acting simultaneously, across and along the crane rail, respectively [*see* IS 875 (Part 2)].

**3.5.4** The crane loads and their combinations to be considered shall be as indicated by the customer. In the absence of any specific indications, the load combinations shall be in accordance with the provisions in IS 875 (Part 2) or as given below:

- a) Vertical loads with full impact from one loaded crane or two cranes in case of tandem operation, together with vertical loads without impact from as many loaded cranes as may be positioned for maximum effect, along with maximum horizontal thrust from one crane only or two in case of tandem operation;
- b) Loads as specified in 3.5.4(a), subject to cranes in maximum of any two bays of the building cross-section shall be considered for multi-bay multi-crane gantries;
- c) The longitudinal thrust on a crane track rail shall be considered for a maximum of two loaded cranes on the track; and
- d) Lateral thrust (surge) and longitudinal thrust acting across and along the crane rail respectively, shall be assumed not to act simultaneously. The effect of each force, shall however be investigated separately.

**3.5.5** While investigating the effect of earthquake forces, the resulting effect from dead loads of all cranes parked in each bay, positioned to cause maximum effect shall be considered.

**3.5.6** The crane runway girders supporting bumpers shall be checked for bumper impact loads also, as specified by the manufacturers.

**3.5.7** Stresses developed due to secondary effects such as handling, erection, temperature and settlement of foundations, if any, shall be appropriately added to the stresses calculated from the combination of loads stated in **3.5.1**, with appropriate partial safety factors.

### 3.6 Geometrical Properties

#### 3.6.1 General

The geometrical properties of the gross and the effective cross-sections of a member or part thereof, shall be calculated on the following basis:

- a) The properties of the gross cross-section shall be calculated from the specified size of the member or part thereof or read from appropriate table.
- b) The properties of the effective cross-section shall be calculated by deducting from the area of the gross cross-section, the following:
  - 1) The sectional area in excess of effective plate width, in case of slender sections (*see 3.7.2*).
  - 2) The sectional areas of all holes in the section except for parts in compression. In case of punched holes, hole size 2 mm in excess of the actual diameter may be deducted.

### 3.7 Classification of Cross-Sections

**3.7.1** Plate elements of a cross-section may buckle locally due to compressive stresses. The local buckling can be avoided before the limit state is achieved by limiting the width to thickness ratio of each element of a cross-section subjected to compression due to axial force, moment or shear.

**3.7.1.1** When plastic analysis is used, the members shall be capable of forming plastic hinges with sufficient rotation capacity (ductility) without local buckling, to enable the redistribution of bending moment required before formation of the failure mechanism.

**3.7.1.2** When elastic analysis is used, the member shall be capable of developing the yield stress under compression without local buckling.

**3.7.2** On basis of the above, four classes of sections are defined as follows:

- a) *Class 1 (Plastic)* — Cross-sections, which can develop plastic hinges and have the rotation capacity required for failure of the structure by formation of plastic mechanism. The width to thickness ratio of plate elements

shall be less than that specified under Class 1 (Plastic), in Table 2.

- b) *Class 2 (Compact)* — Cross-sections, which can develop plastic moment of resistance, but have inadequate plastic hinge rotation capacity for formation of plastic mechanism, due to local buckling. The width to thickness ratio of plate elements shall be less than that specified under Class 2 (Compact), but greater than that specified under Class 1 (Plastic), in Table 2.
- c) *Class 3 (Semi-compact)* — Cross-sections, in which the extreme fiber in compression can reach yield stress, but cannot develop the plastic moment of resistance, due to local buckling. The width to thickness ratio of plate elements shall be less than that specified under Class 3 (Semi-compact), but greater than that specified under Class 2 (Compact), in Table 2.
- d) *Class 4 (Slender)* — Cross-sections in which the elements buckle locally even before reaching yield stress. The width to thickness ratio of plate elements shall be greater than that specified under Class 3 (Semi-compact), in Table 2. In such cases, the effective sections for design shall be calculated either by following the provisions of IS 801 to account for the post-local-buckling strength or by deducting width of the compression plate element in excess of the semi-compact section limit.

When different elements of a cross-section fall under different classes, the section shall be classified as governed by the most critical element.

The maximum value of limiting width to thickness ratios of elements for different classifications of sections are given in Table 2.

#### 3.7.3 Types of Elements

- a) *Internal elements* — These are elements attached along both longitudinal edges to other elements or to longitudinal stiffeners connected at suitable intervals to transverse stiffeners, for example, web of I-section and flanges and web of box section.
- b) *Outside elements or outstands* — These are elements attached along only one of the longitudinal edges to an adjacent element, the other edge being free to displace out of plane, for example flange overhang of an I-section, stem of T-section and legs of an angle section.
- c) *Tapered elements* — These may be treated as flat elements having average thickness as defined in SP 6 (Part 1).

**Table 2 Limiting Width to Thickness Ratio**

(Clauses 3.7.2 and 3.7.4)

Compression Element (1)		Ratio (2)	Class of Section			
			Class 1 Plastic (3)	Class 2 Compact (4)	Class 3 Semi-compact (5)	
Outstanding element of compression flange	Rolled section	$b/t_f$	$9.4\epsilon$	$10.5\epsilon$	$15.7\epsilon$	
	Welded section	$b/t_f$	$8.4\epsilon$	$9.4\epsilon$	$13.6\epsilon$	
Internal element of compression flange	Compression due to bending	$b/t_f$	$29.3\epsilon$	$33.5\epsilon$	$42\epsilon$	
	Axial compression	$b/t_f$	Not applicable			
Web of an I, H or box section	Neutral axis at mid-depth		$d/t_w$	$84\epsilon$	$105\epsilon$	$126\epsilon$
	Generally	If $r_1$ is negative:	$d/t_w$	$\frac{84\epsilon}{1+r_1}$ but $\leq 42\epsilon$	$\frac{105.0\epsilon}{1+r_1}$	$\frac{126.0\epsilon}{1+2r_1}$ but $\leq 42\epsilon$
		If $r_1$ is positive :	$d/t_w$		$\frac{105.0\epsilon}{1+1.5r_1}$ but $\leq 42\epsilon$	
	Axial compression		$d/t_w$	Not applicable		$42\epsilon$
Web of a channel		$d/t_w$	$42\epsilon$	$42\epsilon$	$42\epsilon$	
Angle, compression due to bending (Both criteria should be satisfied)		$b/t$	$9.4\epsilon$	$10.5\epsilon$	$15.7\epsilon$	
		$d/t$	$9.4\epsilon$	$10.5\epsilon$	$15.7\epsilon$	
Single angle, or double angles with the components separated, axial compression (All three criteria should be satisfied)		$b/t$ $d/t$ $(b+d)/t$	Not applicable		$15.7\epsilon$ $15.7\epsilon$ $25\epsilon$	
Outstanding leg of an angle in contact back-to-back in a double angle member		$d/t$	$9.4\epsilon$	$10.5\epsilon$	$15.7\epsilon$	
Outstanding leg of an angle with its back in continuous contact with another component		$d/t$	$9.4\epsilon$	$10.5\epsilon$	$15.7\epsilon$	
Stem of a T-section, rolled or cut from a rolled I-or H- section		$D/t_f$	$8.4\epsilon$	$9.4\epsilon$	$18.9\epsilon$	
Circular hollow tube, including welded tube subjected to: a) moment		$D/t$	$42\epsilon^2$	$52\epsilon^2$	$146\epsilon^2$	
		b) axial compression	$D/t$	Not applicable		$88\epsilon^2$
<p>NOTES</p> <p>1 Elements which exceed semi-compact limits are to be taken as of slender cross-section.</p> <p>2 <math>\epsilon = (250 / f_y)^{1/2}</math>.</p> <p>3 Webs shall be checked for shear buckling in accordance with 8.4.2 when <math>d/t &gt; 67\epsilon</math>, where, <math>b</math> is the width of the element (may be taken as clear distance between lateral supports or between lateral support and free edge, as appropriate), <math>t</math> is the thickness of element, <math>d</math> is the depth of the web, <math>D</math> is the outer diameter of the element (see Fig. 2, 3.7.3 and 3.7.4).</p> <p>4 Different elements of a cross-section can be in different classes. In such cases the section is classified based on the least favourable classification.</p> <p>5 The stress ratio <math>r_1</math> and <math>r_2</math> are defined as:</p> $r_1 = \frac{\text{Actual average axial stress (negative if tensile)}}{\text{Design compressive stress of web alone}}$ $r_2 = \frac{\text{Actual average axial stress (negative if tensile)}}{\text{Design compressive stress of overall section}}$						

The design of slender compression element (Class 4) considering the strength beyond elastic local buckling of element is outside the scope of this standard. Reference may be made to IS 801 for such design provisions. The design of slender web elements may be made as given in 8.2.1.1 for flexure and 8.4.2.2 for shear.

3.7.4 Compound Elements in Built-up Section (see Fig. 2)

In case of compound elements consisting of two or more elements bolted or welded together, the limiting width to thickness ratios as given in Table 2 should be considered on basis of the following:

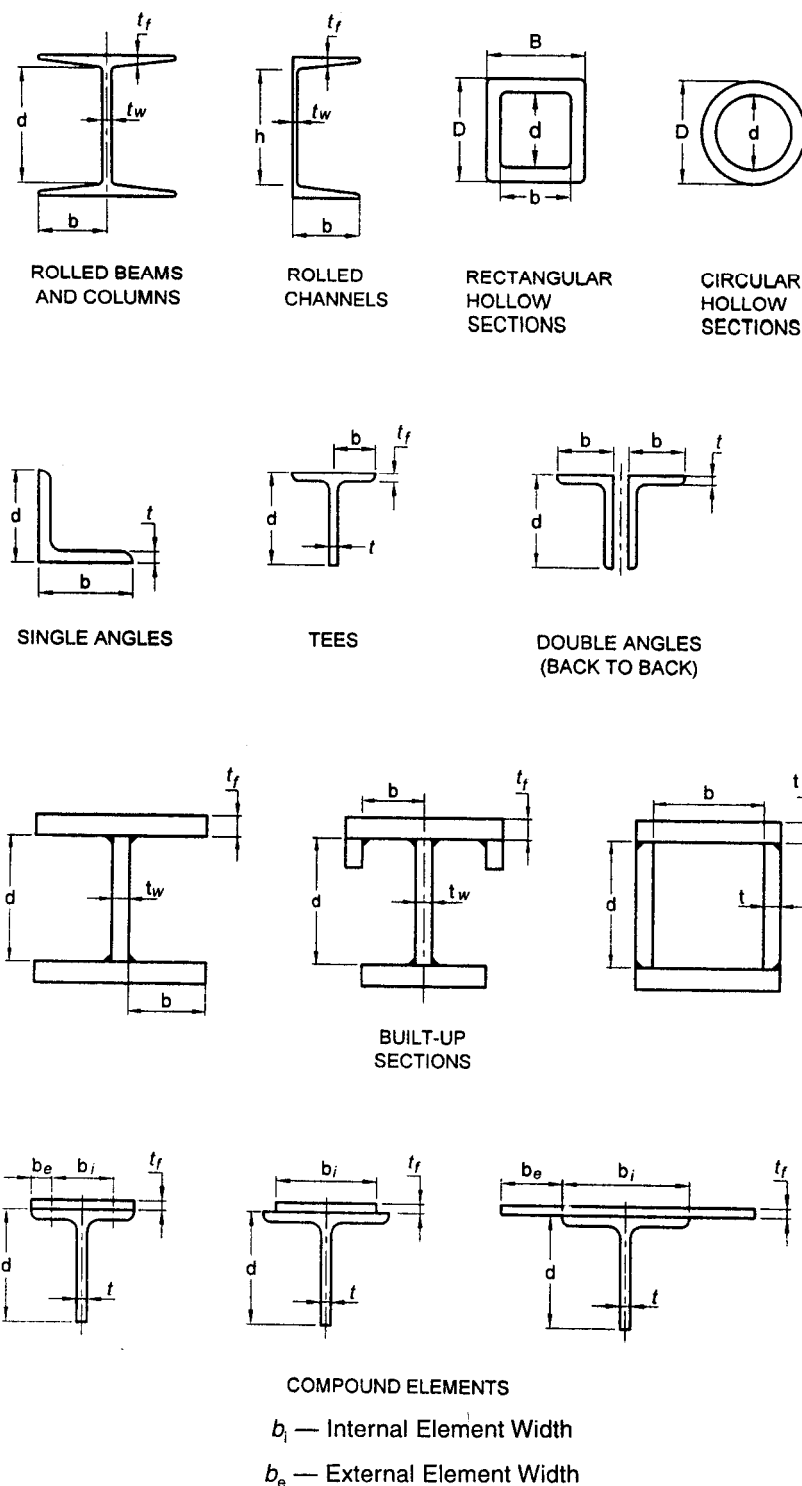


FIG. 2 DIMENSIONS OF SECTIONS

- a) Outstanding width of compound element ( $b_c$ ) to its own thickness.
- b) The internal width of each added plate between the lines of welds or fasteners connecting it to the original section to its own thickness.
- c) Any outstand of the added plates beyond the line of welds or fasteners connecting it to original section to its own thickness.

### 3.8 Maximum Effective Slenderness Ratio

The maximum effective slenderness ratio,  $KL/r$ , values of a beam, strut or tension member shall not exceed those given in Table 3. 'KL' is the effective length of the member and 'r' is appropriate radius of gyration based on the effective section as defined in 3.6.1.

**Table 3 Maximum Values of Effective Slenderness Ratios**

Sl No.	Member	Maximum Effective Slenderness Ratio ( $KL/r$ )
(1)	(2)	(3)
i)	A member carrying compressive loads resulting from dead loads and imposed loads	180
ii)	A tension member in which a reversal of direct stress occurs due to loads other than wind or seismic forces	180
iii)	A member subjected to compression forces resulting only from combination with wind/earthquake actions, provided the deformation of such member does not adversely affect the stress in any part of the structure	250
iv)	Compression flange of a beam against lateral torsional buckling	300
v)	A member normally acting as a tie in a roof truss or a bracing system not considered effective when subject to possible reversal of stress into compression resulting from the action of wind or earthquake forces <sup>1)</sup>	350
vi)	Members always under tension <sup>1)</sup> (other than pre-tensioned members)	400

<sup>1)</sup> Tension members, such as bracing's, pre-tensioned to avoid sag, need not satisfy the maximum slenderness ratio limits.

### 3.9 Resistance to Horizontal Forces

**3.9.1** In designing the steel frame work of a building, provision shall be made (by adequate moment connections or by a system of bracing) to effectively transmit to the foundations all the horizontal forces, giving due allowance for the stiffening effect of the walls and floors, where applicable.

**3.9.2** When the walls, or walls and floors and/or roofs

are capable of effectively transmitting all the horizontal forces directly to the foundations, the structural steel framework may be designed without considering the effect of wind or earthquake.

**3.9.3** Wind and earthquake forces are reversible and therefore call for rigidity and strength under force reversal in both longitudinal and transverse directions. To resist torsional effects of wind and earthquake forces, bracings in plan should be provided and integrally connected with the longitudinal and transverse bracings, to impart adequate torsional resistance to the structure.

**3.9.3.1** In shed type steel mill buildings, adequate bracings shall be provided to transfer the wind or earthquake loads from their points of action to the appropriate supporting members. Where the connections to the interior columns or frames are designed such that the wind or earthquake loads will not be transferred to the interior columns, the exterior columns or frames shall be designed to resist the total wind or earthquake loads. Where the connections to the interior columns and frames are designed such that the wind or earthquake effects are transferred to the interior columns also, and where adequate rigid diaphragm action can be mobilized as in the case of the cast-in place RC slab, both exterior and interior columns and frames may be designed on the assumption that the wind or earthquake load is divided among them in proportion to their relative stiffness. Columns also should be designed to withstand the net uplifting effect caused by excessive wind or earthquake. Additional axial forces arising in adjacent columns due to the vertical component of bracings or due to frame action shall also be accounted for.

**3.9.3.2** Earthquake forces are proportional to the seismic mass as defined in IS 1893. Earthquake forces should be applied at the centre of gravity of all such components of mass and their transfer to the foundation should be ensured. Other construction details, stipulated in IS 4326 should also be followed.

**3.9.3.3** In buildings where high-speed travelling cranes are supported or where a building or structure is otherwise subjected to vibration or sway, triangulated bracing or rigid portal systems shall be provided to reduce the vibration or sway to an acceptable minimum.

#### 3.9.4 Foundations

The foundations of a building or other structures shall be designed to provide the rigidity and strength that has been assumed in the analysis and design of the superstructure.

**3.9.5 Eccentrically Placed Loads**

Where a wall, or other gravity load, is placed eccentrically upon the flange of a supporting steel beam, the beam and its connections shall be designed for torsion, unless the beam is restrained laterally in such a way as to prevent the twisting of the beam.

**3.10 Expansion Joints**

**3.10.1** In view of the large number of factors involved in deciding the location, spacing and nature of expansion joints, the decision regarding provision of expansion joints shall be left to the discretion of the designer.

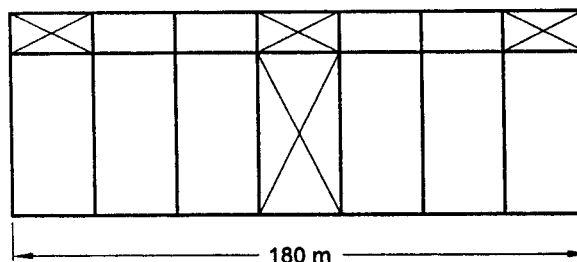
**3.10.2** Structures in which marked changes in plan dimensions take place abruptly, shall be provided with expansion joints at the section where such changes occur. Expansion joints shall be so provided that the necessary movement occurs with minimum resistance at the joint. The gap at the expansion joint should be such that;

- a) It accommodates the expected expansion/contraction due to seasonal and diurnal variation of temperature, and
- b) It avoids pounding of adjacent units under earthquake. The structure adjacent to the joint should preferably be supported on separate columns but not necessarily on separate foundations.

**3.10.3** The details as to the length of a structure where expansion joints have to be provided may be determined after taking into consideration various factors such as temperature, exposure to weather and structural design. The provisions in 3.10.3.1 to 3.10.3.3 are given as general guidance.

**3.10.3.1** If one bay of longitudinal bracing is provided

at the centre of the building or building section, the length of the building section may be restricted to 180 m in case of covered buildings and 120 m in case of open gantries (see Fig. 3).



END OF COVERED BUILDING/SECTION

FIG. 3 MAXIMUM LENGTH OF BUILDING WITH ONE BAY OF BRACING

**3.10.3.2** If more than one bay of longitudinal bracing is provided near the centre of the building/section, the maximum centre line distance between the two lines of bracing may be restricted to 50 m for covered buildings (and 30 m for open gantries) and the maximum distance between the centre of the bracing to the nearest expansion joint/end of building or section may be restricted to 90 m (60 m in case of open gantries). The maximum length of the building section thus may be restricted to 230 m for covered buildings (150 m for open gantries). Beyond this, suitable expansion joints shall be provided (see Fig. 4).

**3.10.3.3** The maximum width of the covered building section should preferably be restricted to 150 m beyond which suitable provisions for the expansion joint may be made.

**3.10.4** When the provisions of these sections are met for a building or open structure, the stress analysis due to temperature is not required.

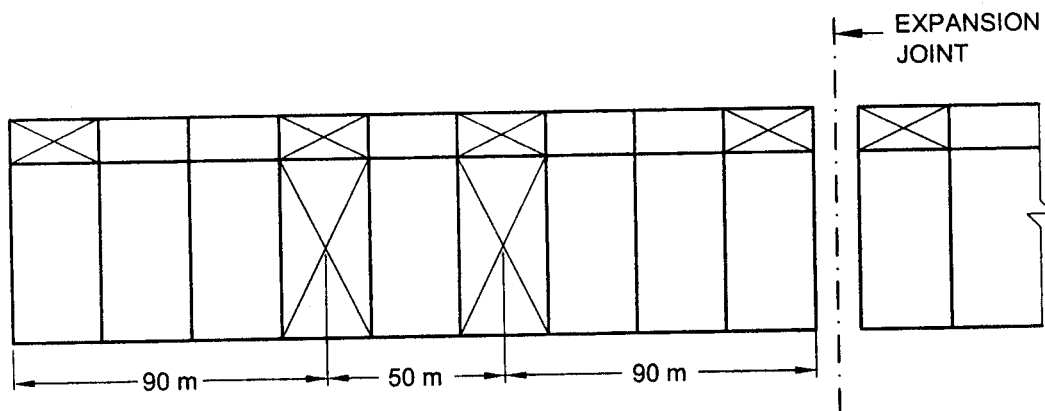


FIG. 4 MAXIMUM LENGTH OF BUILDING/SECTION WITH TWO BAYS OF BRACINGS



## SECTION 4 METHODS OF STRUCTURAL ANALYSIS

### 4.1 Methods of Determining Action Effects

#### 4.1.1 General

For the purpose of complying with the requirements of the limit states of stability, strength and serviceability specified in Section 5, effects of design actions on a structure and its members and connections, shall be determined by structural analysis using the assumptions of 4.2 and 4.3 and one of the following methods of analysis:

- a) Elastic analysis in accordance with 4.4,
- b) Plastic analysis in accordance with 4.5,
- c) Advanced analysis in accordance with Annex B, and
- d) Dynamic analysis in accordance with IS 1893 (Part 1).

The design action effects for design basis earthquake loads shall be obtained only by an elastic analysis. The maximum credible earthquake loads shall be assumed to correspond to the load at which significant plastic hinges are formed in the structure and the corresponding effects shall be obtained by plastic or advanced analysis. More information on analysis and design to resist earthquake is given in Section 12 and IS 1893 (Part 1).

#### 4.1.2 Non-sway and Sway Frames

For the purpose of analysis and design, the structural frames are classified as non-sway and sway frames as given below:

- a) *Non-sway frame* — One in which the transverse displacement of one end of the member relative to the other end is effectively prevented. This applies to triangulated frames and trusses or to frames where in-plane stiffness is provided by bracings, or by shear walls, or by floor slabs and roof decks secured horizontally to walls or to bracing systems parallel to the plane of loading and bending of the frame.
- b) *Sway frame* — One in which the transverse displacement of one end of the member relative to the other end is not effectively prevented. Such members and frames occur in structures which depend on flexural action of members to resist lateral loads and sway, as in moment resisting frames.
- c) A rigid jointed multi-storey frame may be considered as a non-sway frame if in every individual storey, the deflection  $\delta$ , over a storey height  $h_s$ , due to the notional horizontal

loading given in 4.3.6 satisfies the following criteria:

- 1) For clad frames, when the stiffening effect of the cladding is not taken into account in the deflection calculations:

$$\delta \leq \frac{h_s}{2\ 000}$$

- 2) For unclad frame or clad frames, when the stiffening effect of the cladding is taken into account in the deflection calculations:

$$\delta \leq \frac{h_s}{4\ 000}$$

- 3) A frame, which when analyzed considering all the lateral supporting system does not comply with the above criteria, should be classified as a sway frame, even if it is braced or otherwise laterally stiffened.

### 4.2 Forms of Construction Assumed for Structural Analysis

4.2.1 The effects of design action in the members and connections of a structure shall be determined by assuming singly or in combination of the following forms of construction (*see 10.6.1*).

#### 4.2.1.1 Rigid construction

In rigid construction, the connections between members (beam and column) at their junction shall be assumed to have sufficient rigidity to hold the original angles between the members connected at a joint unchanged under loading.

#### 4.2.1.2 Semi-rigid construction

In semi-rigid construction, the connections between members (beam and column) at their junction may not have sufficient rigidity to hold the original angles between the members at a joint unchanged, but shall be assumed to have the capacity to furnish a dependable and known degree of flexural restraint. The relationship between the degree of flexural restraint and the level of the load effects shall be established by any rational method or based on test results (*see Annex F*).

#### 4.2.1.3 Simple construction

In simple construction, the connections between members (beam and column) at their junction will not resist any appreciable moment and shall be assumed to be hinged.

### 4.2.2 Design of Connections

The design of all connections shall be consistent with

the form of construction, and the behaviour of the connections shall not adversely affect any other part of the structure beyond what is allowed for in design. Connections shall be designed in accordance with Section 10.

### 4.3 Assumptions in Analysis

4.3.1 The structure shall be analyzed in its entirety except as follows:

- a) Regular building structures, with orthogonal frames in plan, may be analyzed as a series of parallel two-dimensional sub-structures (part of a structure), the analysis being carried out in each of the two directions, at right angles to each other, except when there is significant load redistribution between the sub-structures (part of a structure). For earthquake loading three dimensional analysis may be necessary to account for effects of torsion and also for multi-component earthquake forces [see IS 1893 (Part 1)].
- b) For vertical loading in a multi-storey building structure, provided with bracing or shear walls to resist all lateral forces, each level thereof, together with the columns immediately above and below, may be considered as a sub-structure, the columns being assumed fixed at the ends remote from the level under consideration.
- c) Where beams at a floor level in a multi-bay building structure are considered as a sub-structure (part of a structure), the bending moment at the support of the beam due to gravity loads may be determined based on the assumption that the beam is fixed at the far end support, one span away from the span under consideration, provided that the floor beam is continuous beyond that support point.

#### 4.3.2 Span Length

The span length of a flexural member in a continuous frame system shall be taken as the distance between centre-to-centre of the supports.

#### 4.3.3 Arrangements of Imposed Loads in Buildings

For building structures, the various arrangements of imposed loads considered for the analysis, shall include at least the following:

- a) Where the loading pattern is fixed, the arrangement concerned.
- b) Where the imposed load is variable and not greater than three-quarters of the dead load, the live load may be taken to be acting on all spans.

- c) Where the imposed load is variable and exceeds three-quarters of the dead load, arrangements of live load acting on the floor under consideration shall include the following cases:

- 1) Imposed load on alternate spans,
- 2) Imposed load on two adjacent spans, and
- 3) Imposed load on all the spans.

#### 4.3.4 Base Stiffness

In the analysis of all structures the appropriate base stiffness about the axis under consideration shall be used. In the absence of the knowledge of the pedestal and foundation stiffness, the following may be assumed:

- a) When the column is rigidly connected to a suitable foundation, the stiffness of the pedestal shall be taken as the stiffness of the column above base plate. However in case of very stiff pedestals and foundations the column may be assumed as fixed at base.
- b) When the column is nominally connected to the foundation, a pedestal stiffness of 10 percent of the column stiffness may be assumed.
- c) When an actual pin or rocker is provided in the connection between the steel column and pedestal, the column is assumed as hinged at base and the pedestal and foundation may be appropriately designed for the reactions from the column.
- d) In case of (a) and (b), the bottom of the pedestal shall be assumed to have the following boundary condition in the absence of any detailed procedure based on theory or tests:
  - 1) When the foundation consist of a group of piles with a pile cap, raft foundation or an isolated footing resting on rock or very hard soil, the pedestal shall be assumed to be fixed at the level of the bottom of footing or at the top of pile cap.
  - 2) When the foundation consist of an isolated footing resting on other soils, pedestal shall be assumed to be hinged at the level of the bottom of footing.
  - 3) When the pedestal is supported by a single pile, which is laterally surrounded by soil providing passive resistance, the pile shall be assumed to be fixed at a depth of 5 times the diameter of the pile

below the ground level in case of compact ground or the top level of compact soil in case of poor soil overlying compact soil.

- 4) When the column is founded into rock, it may be assumed to be fixed at the interface of the column and rock.

#### 4.3.5 Simple Construction

Bending members may be assumed to have their ends connected for shear only and to be free to rotate. In triangulated structures, axial forces may be determined by assuming that all members are pin connected. The eccentricity for stanchion and column shall be assumed in accordance with 7.3.3.

#### 4.3.6 Notional Horizontal Loads

To analyze a frame subjected to gravity loads, considering the sway stability of the frame, notional horizontal forces should be applied. These notional horizontal forces account for practical imperfections and should be taken at each level as being equal to 0.5 percent of factored dead load plus vertical imposed loads applied at that level. The notional load should not be applied along with other lateral loads such as wind and earthquake loads in the analysis.

**4.3.6.1** The notional forces should be applied on the whole structure, in both orthogonal directions, in one direction at a time, at roof and all floor levels or their equivalent. They should be taken as acting simultaneously with factored gravity loads.

**4.3.6.2** The notional force should not be,

- a) applied when considering overturning or overall instability;
- b) combined with other horizontal (lateral) loads;
- c) combined with temperature effects; and
- d) taken to contribute to the net shear on the foundation.

**4.3.6.3** The sway effect using notional load under gantry load case need not be considered if the ratio of height to lateral width of the building is less than unity.

### 4.4 Elastic Analysis

#### 4.4.1 Assumptions

Individual members shall be assumed to remain elastic under the action of the factored design loads for all limit states.

The effect of haunching or any variation of the cross-section along the axis of a member shall be considered, and where significant, shall be taken into account in the determination of the member stiffness.

#### 4.4.2 First-Order Elastic Analysis

In a first-order elastic analysis, the equilibrium of the frame in the undeformed geometry is considered, the changes in the geometry of the frame due to the loading are not accounted for, and changes in the effective stiffness of the members due to axial force are neglected. The effects of these on the first-order bending moments shall be allowed for by using one of the methods of moment amplification of 4.4.3.2 or 4.4.3.3 as appropriate. Where the moment amplification factor  $C_y$ ,  $C_z$ , calculated in accordance with 4.4.3.2 or 4.4.3.3 as appropriate, is greater than 1.4, a second-order elastic analysis in accordance with Annex B shall be carried out.

#### 4.4.3 Second-Order Elastic Analysis

**4.4.3.1** The analysis shall allow for the effects of the design loads acting on the structure and its members in their displaced and deformed configuration. These second-order effects shall be taken into account by using either:

- a) A first-order elastic analysis with moment amplification in accordance with 4.4.2, provided the moment amplification factors,  $C_y$  and  $C_z$  are not greater than 1.4; or
- b) A second-order elastic analysis in accordance with Annex B.

#### 4.4.3.2 Moment amplification for members in non-sway frames

For a member with zero axial compression or a member subject to axial tension, the design bending moment is that obtained from the first order analysis for factored loads, without any amplification.

For a braced member with a design axial compressive force  $P_d$  as determined by the first order analysis, the design bending moment shall be calculated considering moment amplification as in 9.3.2.2.

#### 4.4.3.3 Moment amplification for members in sway frames

The design bending moment shall be calculated as the product of moment amplification factor [see 9.3.2.2 ( $C_{my}$ ,  $C_{mz}$ )] and the moment obtained from the first order analysis of the sway frame, unless analysis considering second order effects is carried out (see 4.4.3).

**4.4.3.4** The calculated bending moments from the first order elastic analysis may be modified by redistribution upto 15 percent of the peak calculated moment of the member under factored load, provided that:

- a) the internal forces and moments in the

members of the frame are in equilibrium with applied loads.

- b) all the members in which the moments are reduced shall belong to plastic or compact section classification (*see 3.7*).

## 4.5 Plastic Analysis

### 4.5.1 Application

The effects of design action throughout or on part of a structure may be determined by a plastic analysis, provided that the requirements of 4.5.2 are met. The distribution of design action effects shall satisfy equilibrium and the boundary conditions.

### 4.5.2 Requirements

When a plastic method of analysis is used, all of the following conditions shall be satisfied, unless adequate ductility of the structure and plastic rotation capacity of its members and connections are established for the design loading conditions by other means of evaluation:

- The yield stress of the grade of the steel used shall not exceed 450 MPa.
- The stress-strain characteristics of the steel shall not be significantly different from those obtained for steels complying with IS 2062 or equivalent and shall be such as to ensure complete plastic moment redistribution. The stress-strain diagram shall have a plateau at the yield stress, extending for at least six times the yield strain. The ratio of the tensile strength to the yield stress specified for the grade of the steel shall not be less than 1.2. The elongation on a gauge length complying with IS 2062 shall not be than 15 percent, and the steel shall exhibit strain-hardening capability. Steels conforming to IS 2062 shall be deemed to satisfy the above requirements.
- The members used shall be hot-rolled or fabricated using hot-rolled plates and sections.
- The cross-section of members not containing plastic hinges should be at least that of compact section (*see 3.7.2*), unless the members meet the strength requirements from elastic analysis.
- Where plastic hinges occur in a member, the proportions of its cross-section should not exceed the limiting values for plastic section given in 3.7.2.
- The cross-section should be symmetrical about its axis perpendicular to the axis of the plastic hinge rotation.
- The members shall not be subject to impact loading, requiring fracture assessment or

fluctuating loading, requiring a fatigue assessment (*see Section 13*).

### 4.5.2.1 Restraints

If practicable, torsional restraint (against lateral buckling) should be provided at all plastic hinge locations. Where not feasible, the restraint should be provided within a distance of  $D/2$  of the plastic hinge location, where  $D$  is the total depth of section.

The torsional restraint requirement at a section as above, need not be met at the last plastic hinge to form, provided it can be clearly identified.

Within a member containing a plastic hinge, the maximum distance  $L_m$  from the restraint at the plastic hinge to an adjacent restraint should be calculated by any rational method or the conservative method given below, so as to prevent lateral buckling.

Conservatively  $L_m$  (in mm) may be taken as

$$L_m \leq \frac{38 r_y}{\left[ \frac{f_c}{130} + \left( \frac{f_y}{250} \right)^2 \left( \frac{x_t}{40} \right)^2 \right]^{1/2}}$$

where

$f_c$  = actual compressive stress on the cross-section due to axial load, in N/mm<sup>2</sup>;

$f_y$  = yield stress, in N/mm<sup>2</sup>;

$r_y$  = radius of gyration about the minor axis, in mm;

$x_t$  = torsional index,  $x_t = 1.132 (AI_w/I_y I_t)^{0.5}$ ;

$A$  = area of cross-section; and

$I_w, I_y, I_t$  = warping constant, second moment of the cross section about the minor axes and St. Venant's torsion constant, respectively.

Where the member has unequal flanges,  $r_y$  should be taken as the lesser of the values of the compression flange only or the whole section.

Where the cross-section of the member varies within the length  $L_m$ , the maximum value of  $r_y$  and the minimum value of  $x_t$  should be used.

The spacing of restraints to member lengths not containing a plastic hinge should satisfy the recommendations of section on lateral buckling strength of beams (*see 8.2.2*). Where the restraints are placed at the limiting distance  $L_m$ , no further checks are required.

### 4.5.2.2 Stiffeners at plastic hinge locations

Web stiffeners should be provided where a concentrated load, which exceeds 10 percent of the shear capacity

of the member, is applied within  $D/2$  of a plastic hinge location (see 8.2.1.2). The stiffener should be provided within a distance of half the depth of the member on either side of the hinge location and be designed to carry the applied load in accordance with 8.7.4. If the stiffeners are flat plates, the outstand width to the thickness ratio,  $b/t$ , should not exceed the values given in the plastic section (see 3.7, Table 2). Where other

sections are used the ratio  $\left(\frac{I_{so}}{I_t}\right)^{1/2}$  should not exceed

the values given for plastic section (for simple outstand, as in 3.7);

where

$I_{so}$  = second moment of area of the stiffener about the face of the element perpendicular to the web; and

$I_t$  = St. Venant's torsion constant of the stiffener.

**4.5.2.3** The frame shall be adequately supported against sway and out-of-plane buckling, by bracings, moment resisting frame or an independent system such as shear wall.

#### 4.5.2.4 Fabrication restriction

Within a length equal to the member depth, on either side of a plastic hinge location, the following restrictions should be applied to the tension flange and noted in the design drawings. Holes if required, should be drilled or else punched 2 mm undersize and reamed. All sheared or hand flame cut edges should be finished smooth by grinding, chipping or planning.

#### 4.5.3 Assumptions in Analysis

The design action effects shall be determined using a rigid-plastic analysis.

It shall be permissible to assume full strength or partial strength connections, provided the capacities of these are used in the analysis, and provided that

- in a full strength connection, the moment capacity of the connection shall be not less than that of the member being connected;
- in a partial strength connection, the moment capacity of the connection may be less than that of the member being connected; and
- in both cases the behaviour of the connection shall be such as to allow all plastic hinges necessary for the collapse mechanism to develop, and shall be such that the required plastic hinge rotation does not exceed the rotation capacity at any of the plastic hinges in the collapse mechanism.

In the case of building structures, it is not normally necessary to consider the effect of alternating plasticity.

#### 4.5.4 Second-Order Elastic Analysis

Any second-order effects of the loads acting on the structure in its deformed configuration may be neglected, provided the following are satisfied:

- For clad frames, provided the stiffening effects of masonry infill wall panels or diaphragms of profiled wall panel is not taken into account, and where elastic buckling load factor,  $\lambda_{cr}$  (see 4.6) satisfies  $\lambda_{cr}/\lambda_p \geq 10$ .  
If  $10 > \lambda_{cr}/\lambda_p \geq 4.6$  the second-order effects may be considered by amplifying the design load effects obtained from plastic analysis by a factor  $\delta_p = \{0.9 \lambda_{cr} / (\lambda_{cr} - 1)\}$ .  
If  $\lambda_{cr}/\lambda_p < 4.6$ , second-order elasto-plastic analysis or second-order elastic analysis (see 4.4.3) is to be carried out.
- For un-clad frames or for clad frames where the stiffening effects of masonry infill or diaphragms of profiled wall panel is taken into account, where elastic buckling load factor,  $\lambda_{cr}$  (see 4.6) satisfies  $\lambda_{cr}/\lambda_p \geq 20$ .  
If  $20 > \lambda_{cr}/\lambda_p \geq 5.75$  the second-order effects may be considered by amplifying the design load effects obtained from plastic analysis by a factor  $\delta_p = \{0.9 \lambda_{cr} / (\lambda_{cr} - 1)\}$ .  
If  $\lambda_{cr}/\lambda_p < 5.75$ , second-order elasto-plastic analysis or second-order elastic analysis (see 4.4.3) shall be carried out.

#### 4.6 Frame Buckling Analysis

**4.6.1** The elastic buckling load factor ( $\lambda_{cr}$ ) shall be the ratio of the elastic buckling load set of the frame to the design load set for the frame, and shall be determined in accordance with 4.6.2.

NOTE — The value of  $\lambda_{cr}$  depends on the load set and has to be evaluated for each possible set of load combination.

#### 4.6.2 In-plane Frame Buckling

The elastic buckling load factor ( $\lambda_{cr}$ ) of a rigid-jointed frame shall be determined by using:

- One of the approximate methods of 4.6.2.1 and 4.6.2.2, or
- A rational elastic buckling analysis of the whole frame.

##### 4.6.2.1 Regular non-sway frames (see 4.1.2)

In a rectangular non-sway frame with regular loading and negligible axial forces in the beams, the Euler buckling stress  $f_{cc}$  for each column shall be determined in accordance with 7.1.2.1. The elastic buckling load factor ( $\lambda_{cr}$ ) for the whole frame shall be taken as the lowest of the ratio of ( $f_{cc}/f_{cd}$ ) for all the columns, where

$f_{cd}$  is the axial compressive stress in the column from the factored load analysis.

#### 4.6.2.2 Regular sway frames

In a rectangular sway frame with regular loading and negligible axial forces in the beams, the buckling load,  $P_{cc}$ , for each column shall be determined as  $P_{cc} = A f_{cc}$  where  $f_{cc}$  is the elastic buckling stress of the column in the plane of frame, obtained in accordance with 7.1.2.1. The elastic buckling load factor  $\lambda_{cr}$  for the whole frame shall be taken as the lowest of all the ratios,  $\lambda_{scr}$ , calculated for each storey of the building, as given below:

$$\lambda_{scr} = \frac{\sum (P_{cc}/L)}{\sum (P/L)}$$

where

- $P$  = member axial force from the factored load analysis, with tension taken as negative; and
- $L$  = column length and the summation includes all columns in the plane frame within a storey.

## SECTION 5 LIMIT STATE DESIGN

### 5.1 Basis for Design

**5.1.1** In the limit state design method, the structure shall be designed to withstand safely all loads likely to act on it throughout its life. It shall not suffer total collapse under accidental loads such as from explosions or impact or due to consequences of human error to an extent beyond the local damages. The objective of the design is to achieve a structure that will remain fit for use during its life with acceptable target reliability. In other words, the probability of a limit state being reached during its lifetime should be very low. The acceptable limit for the safety and serviceability requirements before failure occurs is called a limit state. In general, the structure shall be designed on the basis of the most critical limit state and shall be checked for other limit states.

**5.1.2** Steel structures are to be designed and constructed to satisfy the design requirements with regard to stability, strength, serviceability, brittle fracture, fatigue, fire, and durability such that they meet the following:

- a) Remain fit with adequate reliability and be able to sustain all actions (loads) and other influences experienced during construction and use;
- b) Have adequate durability under normal maintenance;
- c) Do not suffer overall damage or collapse

disproportionately under accidental events like explosions, vehicle impact or due to consequences of human error to an extent beyond local damage. The potential for catastrophic damage shall be limited or avoided by appropriate choice of one or more of the following:

- 1) Avoiding, eliminating or reducing exposure to hazards, which the structure is likely to sustain.
- 2) Choosing structural forms, layouts and details and designing such that:
  - i) the structure has low sensitivity to hazardous conditions; and
  - ii) the structure survives with only local damage even after serious damage to any one individual element by the hazard.
- 3) Choosing suitable material, design and detailing procedure, construction specifications, and control procedures for shop fabrication and field construction as relevant to the particular structure.

The following conditions may be satisfied to avoid a disproportionate collapse:

- a) The building should be effectively tied together at each principal floor level and each column should be effectively held in position by means of continuous ties (beams) nearly orthogonal, except where the steel work supports only cladding weighing not more than 0.7 kN/m<sup>2</sup> along with imposed and wind loads. These ties must be steel members such as beams, which may be designed for other purposes, steel bar reinforcement anchoring the steel frame to concrete floor or steel mesh reinforcement in composite slab with steel profiled sheeting directly connected to beam with shear connectors. These steel ties and their end connections should be capable of resisting factored tensile force not less than the factored dead and imposed loads acting on the floor area tributary to the tie nor less than 75 kN. Such connection of ties to edge column should also be capable of resisting 1 percent of the maximum axial compression in the column at the level due to factored dead and imposed loads. All column splices should be capable of resisting a tensile force equal to the largest of a factored dead and live load reaction from a single floor level located between that column splice and the next column splice below that splice. Lateral load system to resist notional horizontal loads prescribed in 4.3.6 should be distributed

throughout the building in nearly orthogonal directions so that no substantial portions is connected at only one point to such a system. Precast concrete or other heavy floor or roof units should be effectively anchored in the direction of their span either to each other over the support or directly to the support.

- b) Where the above conditions to tie the columns to the floor adequately are not satisfied each storey of the building should be checked to ensure that disproportionate collapse would not precipitate by the notional removal, one at a time, of each column.
- c) Where each floor is not laterally supported by more than one system, check should be made at each storey by removing one such lateral support system at a time to ensure that disproportionate collapse would not occur. The collapse is considered disproportionate, if more than 15 percent of the floor or roof area of 70 m<sup>2</sup> collapse at that level and at one adjoining level either above or below it, under a load equal to 1.05 or 0.9 times the dead load, 0.33 times temporary or full imposed load of permanent nature (as in storage buildings) and 0.33 times wind load acting together.

**5.1.3** Structures designed for unusual or special functions shall comply with any other relevant additional limit state considered appropriate to that structure.

**5.1.4** Generally structures and elements shall be designed by limit state method. Where limit state method cannot be conveniently adopted, working stress design (*see* Section 11) may be used.

## 5.2 Limit State Design

**5.2.1** For achieving the design objectives, the design shall be based on characteristic values for material strengths and applied loads (actions), which take into account the probability of variations in the material strengths and in the loads to be supported. The characteristic values shall be based on statistical data, if available. Where such data is not available, these shall be based on experience. The design values are derived from the characteristic values through the use of partial safety factors, both for material strengths and for loads. In the absence of special considerations, these factors shall have the values given in this section according to the material, the type of load and the limit state being considered. The reliability of design is ensured by satisfying the requirement:

$$\text{Design action} \leq \text{Design strength}$$

**5.2.2** Limit states are the states beyond which the structure

no longer satisfies the performance requirements specified. The limit states are classified as:

- a) Limit state of strength; and
- b) Limit state of serviceability.

**5.2.2.1** The limit states of strength are those associated with failures (or imminent failure), under the action of probable and most unfavourable combination of loads on the structure using the appropriate partial safety factors, which may endanger the safety of life and property. The limit state of strength includes:

- a) Loss of equilibrium of the structure as a whole or any of its parts or components.
- b) Loss of stability of the structure (including the effect of sway where appropriate and overturning) or any of its parts including supports and foundations.
- c) Failure by excessive deformation, rupture of the structure or any of its parts or components.
- d) Fracture due to fatigue.
- e) Brittle fracture.

**5.2.2.2** The limit state of serviceability include:

- a) Deformation and deflections, which may adversely affect the appearance or effective use of the structure or may cause improper functioning of equipment or services or may cause damages to finishes and non-structural members.
- b) Vibrations in the structure or any of its components causing discomfort to people, damages to the structure, its contents or which may limit its functional effectiveness. Special consideration shall be given to systems susceptible to vibration, such as large open floor areas free of partitions to ensure that such vibrations are acceptable for the intended use and occupancy (*see* Annex C).
- c) Repairable damage or crack due to fatigue.
- d) Corrosion, durability.
- e) Fire.

## 5.3 Actions

The actions (loads) to be considered in design include direct actions (loads) experienced by the structure due to self weight, external actions etc., and imposed deformations such as that due to temperature and settlements.

### 5.3.1 Classification of Actions

Actions are classified by their variation with time as given below:

- a) *Permanent actions* ( $Q_p$ ): Actions due to self-weight of structural and non-structural

components, fittings, ancillaries, and fixed equipment, etc.

- b) *Variable actions* ( $Q_v$ ): Actions due to construction and service stage loads such as imposed (live) loads (crane loads, snow loads, etc.), wind loads, and earthquake loads, etc.
- c) *Accidental actions* ( $Q_a$ ): Actions expected due to explosions, and impact of vehicles, etc.

**5.3.2 Characteristic Actions (Loads)**

**5.3.2.1** The Characteristic Actions,  $Q_c$ , are the values of the different actions that are not expected to be exceeded with more than 5 percent probability, during the life of the structure and they are taken as:

- a) the self-weight, in most cases calculated on the basis of nominal dimensions and unit weights [see IS 875 (Part 1)].
- b) the variable loads, values of which are specified in relevant standard [see IS 875 (all Parts) and IS 1893 (Part 1)].
- c) the upper limit with a specified probability (usually 5 percent) not exceeding during some reference period (design life).
- d) specified by client, or by designer in consultation with client, provided they satisfy the minimum provisions of the relevant loading standard.

**5.3.2.2** The characteristic values of accidental loads generally correspond to the value specified by relevant code, standard or client. The design for accidental load

is generally not required in building unless it is required by client or approving authority in which case, generally recommendation in 5.1.2 c) or specialist literature shall be followed.

**5.3.3 Design Actions**

The Design Actions,  $Q_d$ , is expressed as  $Q_d = \sum_k \gamma_{fk} Q_{ck}$

where

$\gamma_{fk}$  = partial safety factor for different loads  $k$ , given in Table 4 to account for:

- a) Possibility of unfavourable deviation of the load from the characteristic value,
- b) Possibility of inaccurate assessment of the load,
- c) Uncertainty in the assessment of effects of the load, and
- d) Uncertainty in the assessment of the limit states being considered.

The loads or load effects shall be multiplied by the relevant  $\gamma_f$  factors, given in Table 4, to get the design loads or design load effects.

**5.4 Strength**

The ultimate strength calculation may require consideration of the following:

- a) Loss of equilibrium of the structure or any part of it, considered as a rigid body; and
- b) Failure by excessive deformation, rupture or

**Table 4 Partial Safety Factors for Loads,  $\gamma_f$ , for Limit States**  
(Clauses 3.5.1 and 5.3.3)

Combination	Limit State of Strength					Limit State of Serviceability			
	DL	LL <sup>1)</sup>		WL/EL	AL	DL	LL <sup>1)</sup>		WL/EL
		Leading	Accompanying				Leading	Accompanying	
(1)	(2)	(3)	(4)	(5)	(6)	(7)	(8)	(9)	(10)
DL+LL+CL	1.5	1.5	1.05	—	—	1.0	1.0	1.0	—
DL+LL+CL+	1.2	1.2	1.05	0.6	—	1.0	0.8	0.8	0.8
WL/EL	—	1.2	0.53	1.2	—	—	—	—	—
DL+WL/EL	1.5 (0.9) <sup>2)</sup>	—	—	1.5	—	1.0	—	—	1.0
DL+ER	1.2	1.2	—	—	—	—	—	—	—
DL+LL+AL	1.0	0.35	0.35	—	1.0	—	—	—	—

<sup>1)</sup> When action of different live loads is simultaneously considered, the leading live load shall be considered to be the one causing the higher load effects in the member/section.

<sup>2)</sup> This value is to be considered when the dead load contributes to stability against overturning is critical or the dead load causes reduction in stress due to other loads.

**Abbreviations:**

DL = Dead load, LL = Imposed load (Live loads), WL = Wind load, CL = Crane load (Vertical/Horizontal), AL = Accidental load, ER = Erection load, EL = Earthquake load.

NOTE — The effects of actions (loads) in terms of stresses or stress resultants may be obtained from an appropriate method of analysis as in 4.



loss of stability of the structure or any part of it including support and foundation.

#### 5.4.1 Design Strength

The Design Strength,  $S_d$ , is obtained as given below from ultimate strength,  $S_u$  and partial safety factors for materials,  $\gamma_m$  given in Table 5.

$$S_d = S_u / \gamma_m$$

where partial safety factor for materials,  $\gamma_m$  account for:

- Possibility of unfavourable deviation of material strength from the characteristic value,
- Possibility of unfavourable variation of member sizes,
- Possibility of unfavourable reduction in member strength due to fabrication and tolerances, and
- Uncertainty in the calculation of strength of the members.

### 5.5 Factors Governing the Ultimate Strength

#### 5.5.1 Stability

Stability shall be ensured for the structure as a whole and for each of its elements. This should include, overall frame stability against overturning and sway, as given in 5.5.1.1 and 5.5.1.2.

##### 5.5.1.1 Stability against overturning

The structure as a whole or any part of it shall be designed to prevent instability due to overturning, uplift or sliding under factored load as given below:

- The Actions shall be divided into components aiding instability and components resisting instability.
- The permanent and variable actions and their effects causing instability shall be combined using appropriate load factors as per the Limit State requirements, to obtain maximum destabilizing effect.

- The permanent actions (loads) and effects contributing to resistance shall be multiplied with a partial safety factor 0.9 and added together with design resistance (after multiplying with appropriate partial safety factor). Variable actions and their effects contributing to resistance shall be disregarded.
- The resistance effect shall be greater than or equal to the destabilizing effect. Combination of imposed and dead loads should be such as to cause most severe effect on overall stability.

##### 5.5.1.2 Sway stability

The whole structure, including portions between expansion joints, shall be adequately stiff against sway. To ensure this, in addition to designing for applied horizontal loads, a separate check should be carried out for notional horizontal loads such as given in 4.3.6 to evaluate the sway under gravity loads.

##### 5.5.2 Fatigue

Generally fatigue need not be considered unless a structure or element is subjected to numerous significant fluctuations of stress. Stress changes due to fluctuations in wind loading normally need not be considered. Fatigue design shall be in accordance with Section 13. When designing for fatigue, the partial safety factor for load,  $\gamma_r$  equal to unity shall be used for the load causing stress fluctuation and stress range.

##### 5.5.3 Plastic Collapse

Plastic analysis and design may be used, if the requirement specified under the plastic method of analysis (*see* 4.5) are satisfied.

### 5.6 Limit State of Serviceability

Serviceability limit state is related to the criteria governing normal use. Serviceability limit state is limit state beyond which the service criteria specified below, are no longer met:

- Deflection limit,

**Table 5 Partial Safety Factor for Materials,  $\gamma_m$**

(Clause 5.4.1)

Sl No.	Definition	Partial Safety Factor	
		Shop Fabrications	Field Fabrications
i)	Resistance, governed by yielding, $\gamma_{m0}$	1.10	
ii)	Resistance of member to buckling, $\gamma_{m0}$	1.10	
iii)	Resistance, governed by ultimate stress, $\gamma_{m1}$	1.25	
iv)	Resistance of connection:		
	a) Bolts-Friction Type, $\gamma_{mf}$	1.25	1.25
	b) Bolts-Bearing Type, $\gamma_{mb}$	1.25	1.25
	c) Rivets, $\gamma_{mr}$	1.25	1.25
	d) Welds, $\gamma_{mw}$	1.25	1.50

- b) Vibration limit,
- c) Durability consideration, and
- d) Fire resistance.

Unless specified otherwise, partial safety factor for loads,  $\gamma_f$ , of value equal to unity shall be used for all loads leading to serviceability limit states to check the adequacy of the structure under serviceability limit states.

### 5.6.1 Deflection

The deflection under serviceability loads of a building

or a building component should not impair the strength of the structure or components or cause damage to finishings. Deflections are to be checked for the most adverse but realistic combination of service loads and their arrangement, by elastic analysis, using a load factor of 1.0. Table 6 gives recommended limits of deflections for certain structural members and systems. Circumstances may arise where greater or lesser values would be more appropriate depending upon the nature of material in element to be supported (vulnerable to cracking or not) and intended use of the structure, as required by client.

**Table 6 Deflection Limits**

Type of Building	Deflection	Design Load	Member	Supporting	Maximum Deflection	
(1)	(2)	(3)	(4)	(5)	(6)	
Industrial Buildings	Vertical	Live load/ Wind load	Purlins and Girts	Elastic cladding	Span/150	
				Brittle cladding	Span/180	
		Live load	Simple span	Elastic cladding	Span/240	
				Brittle cladding	Span/300	
		Live load	Cantilever span	Elastic cladding	Span/120	
				Brittle cladding	Span/150	
		Live load/ Wind load	Rafter supporting	Profiled Metal Sheeting	Span/180	
			Plastered Sheeting	Span/240		
		Lateral	Crane load (Manual operation)	Gantry	Crane	Span/500
	Crane load (Electric operation up to 50 t)		Gantry	Crane	Span/750	
Crane load (Electric operation over 50 t)	Gantry		Crane	Span/1 000		
	Lateral	No cranes	Column	Elastic cladding	Height/150	
				Masonry/Brittle cladding	Height/240	
Crane + wind		Gantry (lateral)	Crane (absolute)	Span/400		
	Lateral	Crane + wind	Column/frame	Relative displacement between rails supporting crane	10 mm	
				Gantry (Elastic cladding; pendent operated)	Height/200	
				Gantry (Brittle cladding; cab operated)	Height/400	
Other Buildings	Vertical	Live load	Floor and Roof	Elements not susceptible to cracking	Span/300	
				Elements susceptible to cracking	Span/360	
	Vertical	Live load	Cantilever	Elements not susceptible to cracking	Span/150	
				Elements susceptible to cracking	Span/180	
	Lateral	Wind	Building	Elastic cladding	Height/300	
			Brittle cladding	Height/500		
	Lateral	Wind	Inter storey drift	—	Storey height/300	

**5.6.1.1** Where the deflection due to the combination of dead load and live load is likely to be excessive, consideration should be given to pre-camber the beams, trusses and girders. The value of desired camber shall be specified in design drawing. Generally, for spans greater than 25 m, a camber approximately equal to the deflection due to dead loads plus half the live load may be used. The deflection of a member shall be calculated without considering the impact factor or dynamic effect of the loads on deflection. Roofs, which are very flexible, shall be designed to withstand any additional load that is likely to occur as a result of ponding of water or accumulation of snow or ice.

### 5.6.2 Vibration

Suitable provisions in the design shall be made for the dynamic effects of live loads, impact loads and vibration due to machinery operating loads. In severe cases possibility of resonance, fatigue or unacceptable vibrations shall be investigated. Unusually flexible structures (generally the height to effective width of lateral load resistance system exceeding 5:1) shall be investigated for lateral vibration under dynamic wind loads. Structures subjected to large number of cycles of loading shall be designed against fatigue failure, as specified in Section 13. Floor vibration effect shall be considered using specialist literature (*see Annex C*).

### 5.6.3 Durability

Factors that affect the durability of the buildings, under conditions relevant to their intended life, are listed below:

- Environment,
- Degree of exposure,
- Shape of the member and the structural detail,
- Protective measure, and
- Ease of maintenance.

**5.6.3.1** The durability of steel structures shall be ensured by following recommendations in Section 15. Specialist literature may be referred to for more detailed and additional information in design for durability.

### 5.6.4 Fire Resistance

Fire resistance of a steel member is a function of its mass, its geometry, the actions to which it is subjected, its structural support condition, fire protection measures adopted and the fire to which it is exposed. Design provisions to resist fire are briefly discussed in Section 16. Specialist literature may be referred to for more detailed information in design of fire resistance of steel structures.

## SECTION 6 DESIGN OF TENSION MEMBERS

### 6.1 Tension Members

Tension members are linear members in which axial forces act to cause elongation (stretch). Such members can sustain loads upto the ultimate load, at which stage they may fail by rupture at a critical section. However, if the gross area of the member yields over a major portion of its length before the rupture load is reached, the member may become non-functional due to excessive elongation. Plates and other rolled sections in tension may also fail by block shear of end bolted regions (*see 6.4.1*).

The factored design tension  $T$ , in the members shall satisfy the following requirement:

$$T < T_d$$

where

$T_d$  = design strength of the member.

The design strength of a member under axial tension,  $T_d$ , is the lowest of the design strength due to yielding of gross section,  $T_{dg}$ , rupture strength of critical section,  $T_{dn}$ , and block shear  $T_{db}$ , given in 6.2, 6.3 and 6.4, respectively.

### 6.2 Design Strength Due to Yielding of Gross Section

The design strength of members under axial tension,  $T_{dg}$ , as governed by yielding of gross section, is given by

$$T_{dg} = A_g f_y / \gamma_{m0}$$

where

$f_y$  = yield stress of the material,

$A_g$  = gross area of cross-section, and

$\gamma_{m0}$  = partial safety factor for failure in tension by yielding (*see Table 5*).

### 6.3 Design Strength Due to Rupture of Critical Section

#### 6.3.1 Plates

The design strength in tension of a plate,  $T_{dn}$ , as governed by rupture of net cross-sectional area,  $A_n$ , at the holes is given by

$$T_{dn} = 0.9 A_n f_u / \gamma_{m1}$$

where

$\gamma_{m1}$  = partial safety factor for failure at ultimate stress (*see Table 5*),

$f_u$  = ultimate stress of the material, and

$A_n$  = net effective area of the member given by,

$$A_n = \left[ b - nd_h + \sum_i \frac{p_{si}^2}{4g_i} \right] t$$

where

$b, t$  = width and thickness of the plate, respectively,

$d_h$  = diameter of the bolt hole (2 mm in addition to the diameter of the hole, in case the directly punched holes),

$g$  = gauge length between the bolt holes, as shown in Fig. 5,

$p_s$  = staggered pitch length between line of bolt holes, as shown in Fig. 5,

$n$  = number of bolt holes in the critical section, and

$i$  = subscript for summation of all the inclined legs.

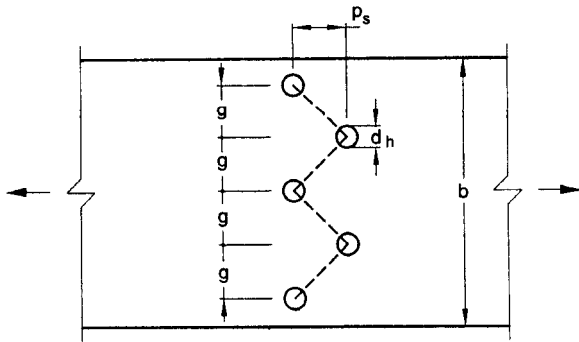


FIG. 5 PLATES WITH BOLTS HOLES IN TENSION

### 6.3.2 Threaded Rods

The design strength of threaded rods in tension,  $T_{dn}$ , as governed by rupture is given by

$$T_{dn} = 0.9 A_n f_u / \gamma_{m1}$$

where

$A_n$  = net root area at the threaded section.

### 6.3.3 Single Angles

The rupture strength of an angle connected through one leg is affected by shear lag. The design strength,  $T_{dn}$ , as governed by rupture at net section is given by:

$$T_{dn} = 0.9 A_{nc} f_u / \gamma_{m1} + \beta A_{go} f_y / \gamma_{m0}$$

where

$$\beta = 1.4 - 0.076 (w/t) (f_y/f_u) (b_s/L_c) \leq (f_u \gamma_{m0} / f_y \gamma_{m1}) \geq 0.7$$

where

$w$  = outstand leg width,

$b_s$  = shear lag width, as shown in Fig. 6, and

$L_c$  = length of the end connection, that is the distance between the outermost bolts in the end joint measured along the load direction or length of the weld along the load direction.

For preliminary sizing, the rupture strength of net section may be approximately taken as:

$$T_{dn} = \alpha A_n f_u / \gamma_{m1}$$

where

$\alpha$  = 0.6 for one or two bolts, 0.7 for three bolts and 0.8 for four or more bolts along the length in the end connection or equivalent weld length;

$A_n$  = net area of the total cross-section;

$A_{nc}$  = net area of the connected leg;

$A_{go}$  = gross area of the outstanding leg; and

$t$  = thickness of the leg.

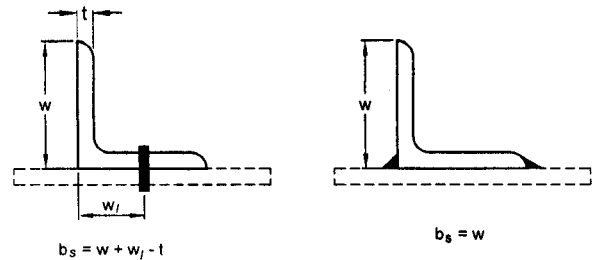


FIG. 6 ANGLES WITH SINGLE LEG CONNECTIONS

### 6.3.4 Other Section

The rupture strength,  $T_{dn}$ , of the double angles, channels, I-sections and other rolled steel sections, connected by one or more elements to an end gusset is also governed by shear lag effects. The design tensile strength of such sections as governed by tearing of net section may also be calculated using equation in 6.3.3, where  $\beta$  is calculated based on the shear lag distance,  $b_s$ , taken from the farthest edge of the outstanding leg to the nearest bolt/weld line in the connected leg of the cross-section.

### 6.4 Design Strength Due to Block Shear

The strength as governed by block shear at an end connection of plates and angles is calculated as given in 6.4.1.

#### 6.4.1 Bolted Connections

The block shear strength,  $T_{db}$  of connection shall be taken as the smaller of,

$$T_{db} = [ A_{vg} f_y / (\sqrt{3} \gamma_{m0}) + 0.9 A_{tn} f_u / \gamma_{m1} ]$$

or

$$T_{db} = (0.9 A_{vn} f_u / (\sqrt{3} \gamma_{m1}) + A_{tg} f_y / \gamma_{m0})$$

where

$A_{vg}, A_{vn}$  = minimum gross and net area in shear along bolt line parallel to external force, respectively (1-2 and 3-4 as shown in Fig. 7A and 1-2 as shown in Fig. 7B),

$A_{tg}, A_{tn}$  = minimum gross and net area in tension from the bolt hole to the toe of the angle, end bolt line, perpendicular to the line of force, respectively (2-3 as shown in Fig. 7B), and

$f_u, f_y$  = ultimate and yield stress of the material, respectively.

**6.4.2 Welded Connection**

The block shear strength,  $T_{db}$  shall be checked for welded end connections by taking an appropriate section in the member around the end weld, which can shear off as a block.

**SECTION 7  
DESIGN OF COMPRESSION MEMBERS**

**7.1 Design Strength**

**7.1.1** Common hot rolled and built-up steel members used for carrying axial compression, usually fail by flexural buckling. The buckling strength of these members is affected by residual stresses, initial bow and accidental eccentricities of load. To account for all these factors, the strength of members subjected to axial compression is defined by buckling class a, b, c, or d as given Table 7.

**7.1.2** The design compressive strength  $P_d$ , of a member is given by:

$$P < P_d$$

where

$$P_d = A_e f_{cd}$$

where

$A_e$  = effective sectional area as defined in 7.3.2, and

$f_{cd}$  = design compressive stress, obtained as per 7.1.2.1.

**7.1.2.1** The design compressive stress,  $f_{cd}$ , of axially loaded compression members shall be calculated using the following equation:

$$f_{cd} = \frac{f_y / \gamma_{m0}}{\phi + [\phi^2 - \lambda^2]^{0.5}} = \chi f_y / \gamma_{m0} \leq f_y / \gamma_{m0}$$

where

$$\phi = 0.5 [1 + \alpha (\lambda - 0.2) + \lambda^2]$$

$\lambda$  = non-dimensional effective slenderness ratio

$$= \sqrt{f_y / f_{cc}} = \sqrt{f_y \left( \frac{KL}{r} \right)^2 / \pi^2 E}$$

$$f_{cc} = \text{Euler buckling stress} = \frac{\pi^2 E}{\left( \frac{KL}{r} \right)^2}$$

where

$KL/r$  = effective slenderness ratio or ratio of effective length,  $KL$  to appropriate radius of gyration,  $r$ ;

$\alpha$  = imperfection factor given in Table 7;

$\chi$  = stress reduction factor (see Table 8) for different buckling class, slenderness ratio and yield stress

$$= \frac{1}{\left[ \phi + (\phi^2 - \lambda^2)^{0.5} \right]}$$

$\lambda_{m0}$  = partial safety factor for material strength.

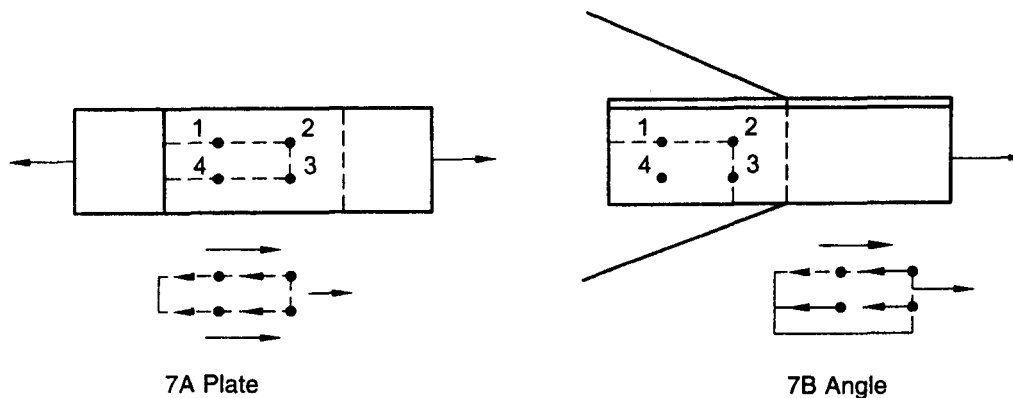


FIG. 7 BLOCK SHEAR FAILURE

NOTE — Calculated values of design compressive stress,  $f_{cd}$  for different buckling classes are given in Table 9.

**7.1.2.2** The classification of different sections under different buckling class a, b, c or d, is given in Table 10. The stress reduction factor  $\chi$ , and the design compressive stress  $f_{cd}$ , for different buckling class, yield stress, and effective slenderness ratio is given in Table 8 for convenience. The curves corresponding to different buckling class are presented in non-dimensional form, in Fig. 8.

**Table 7 Imperfection Factor,  $\alpha$**   
(Clauses 7.1.1 and 7.1.2.1)

Buckling Class	a	b	c	d
$\alpha$	0.21	0.34	0.49	0.76

## 7.2 Effective Length of Compression Members

**7.2.1** The effective length  $KL$ , is calculated from the actual length  $L$ , of the member, considering the rotational and relative translational boundary conditions at the ends. The actual length shall be taken as the length from centre-to-centre of its intersections with the supporting members in the plane of the buckling deformation. In the case of a member with a free end, the free standing length from the center of the intersecting member at the supported end, shall be taken as the actual length.

### 7.2.2 Effective Length

Where the boundary conditions in the plane of buckling

can be assessed, the effective length,  $KL$  can be calculated on the basis of Table 11. Where frame analysis does not consider the equilibrium of a framed structure in the deformed shape (second-order analysis or advanced analysis), the effective length of compression members in such cases can be calculated using the procedure given in **D-1**. The effective length of stepped column in single storey buildings can be calculated using the procedure given in **D-2**.

### 7.2.3 Eccentric Beam Connection

In cases where the beam connections are eccentric in plan with respect to the axes of the column, the same conditions of restraint as in concentric connection shall be deemed to apply, provided the connections are carried across the flange or web of the columns as the case may be, and the web of the beam lies within, or in direct contact with the column section. Where practical difficulties prevent this, the effective length shall be taken as equal to the distance between points of restraint, in non-sway frames.

### 7.2.4 Compression Members in Trusses

In the case of bolted, riveted or welded trusses and braced frames, the effective length,  $KL$ , of the compression members shall be taken as 0.7 to 1.0 times the distance between centres of connections, depending on the degree of end restraint provided. In the case of members of trusses, buckling in the plane perpendicular to the plane of the truss, the effective length,  $KL$  shall be taken as the distance between the centres of intersection. The design of angle struts shall be as specified in 7.5.

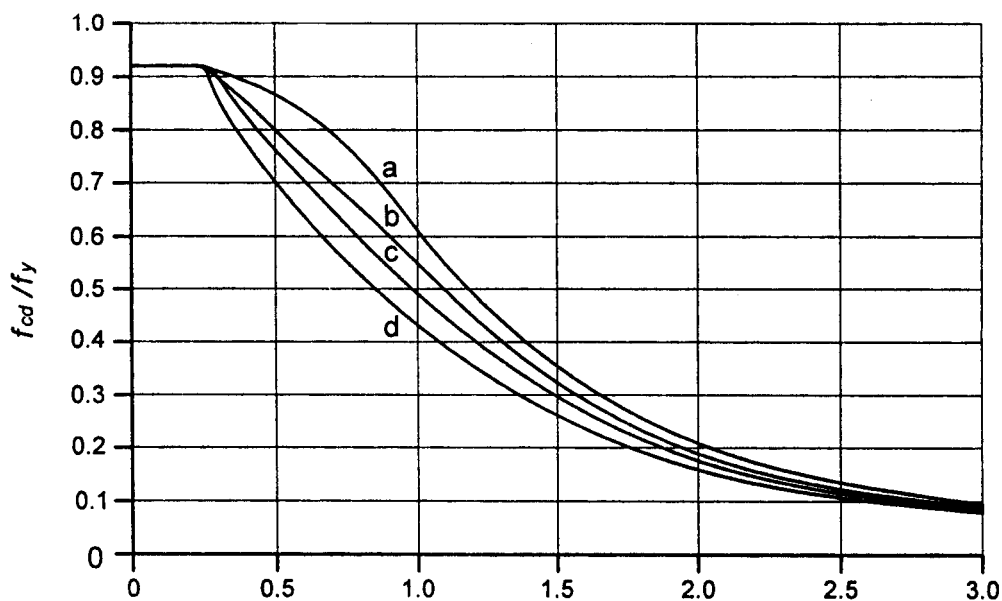


FIG. 8 COLUMN BUCKLING CURVES

**Table 8(a) Stress Reduction Factor,  $\chi$  for Column Buckling Class a**  
(Clauses 7.1.2.1 and 7.1.2.2)

$KL/r$ ↓	Yield Stress, $f_y$ (MPa)																								
	200	210	220	230	240	250	260	280	300	320	340	360	380	400	420	450	480	510	540						
10	1.000	1.000	1.000	1.000	1.000	1.000	1.000	1.000	1.000	1.000	1.000	1.000	1.000	1.000	1.000	1.000	1.000	1.000	1.000						
20	1.000	0.999	0.998	0.997	0.995	0.994	0.993	0.993	0.990	0.988	0.986	0.984	0.983	0.981	0.979	0.977	0.975	0.972	0.970						
30	0.977	0.975	0.974	0.972	0.970	0.969	0.967	0.965	0.961	0.957	0.954	0.951	0.948	0.946	0.943	0.938	0.934	0.930	0.925						
40	0.952	0.949	0.947	0.944	0.942	0.939	0.937	0.934	0.926	0.921	0.916	0.911	0.906	0.901	0.896	0.888	0.881	0.873	0.865						
50	0.923	0.919	0.915	0.911	0.908	0.904	0.900	0.896	0.884	0.876	0.867	0.859	0.851	0.842	0.834	0.820	0.807	0.794	0.780						
60	0.888	0.883	0.877	0.871	0.865	0.859	0.853	0.847	0.828	0.816	0.803	0.790	0.777	0.763	0.750	0.730	0.710	0.690	0.671						
70	0.846	0.837	0.829	0.820	0.811	0.803	0.794	0.785	0.758	0.740	0.722	0.703	0.686	0.668	0.651	0.626	0.602	0.579	0.557						
80	0.793	0.781	0.769	0.757	0.746	0.734	0.722	0.710	0.675	0.653	0.631	0.610	0.589	0.570	0.551	0.525	0.501	0.478	0.458						
90	0.730	0.715	0.700	0.685	0.671	0.657	0.643	0.628	0.590	0.565	0.542	0.520	0.500	0.481	0.463	0.439	0.416	0.396	0.377						
100	0.661	0.644	0.627	0.610	0.594	0.579	0.564	0.549	0.510	0.486	0.463	0.443	0.424	0.407	0.390	0.368	0.348	0.331	0.314						
110	0.591	0.573	0.555	0.538	0.522	0.507	0.492	0.478	0.440	0.418	0.397	0.379	0.362	0.346	0.332	0.312	0.295	0.279	0.265						
120	0.525	0.507	0.489	0.473	0.458	0.443	0.429	0.416	0.381	0.361	0.343	0.326	0.311	0.297	0.284	0.267	0.252	0.238	0.226						
130	0.466	0.448	0.432	0.416	0.402	0.388	0.376	0.364	0.332	0.314	0.298	0.283	0.269	0.257	0.246	0.231	0.217	0.206	0.195						
140	0.413	0.397	0.382	0.368	0.355	0.342	0.331	0.320	0.291	0.275	0.260	0.247	0.235	0.224	0.214	0.201	0.189	0.179	0.170						
150	0.368	0.353	0.339	0.326	0.314	0.303	0.293	0.283	0.257	0.243	0.229	0.218	0.207	0.197	0.189	0.177	0.166	0.157	0.149						
160	0.329	0.316	0.303	0.291	0.280	0.270	0.261	0.252	0.229	0.215	0.204	0.193	0.184	0.175	0.167	0.157	0.147	0.139	0.132						
170	0.296	0.283	0.272	0.261	0.251	0.242	0.233	0.225	0.204	0.192	0.182	0.172	0.164	0.156	0.149	0.140	0.131	0.124	0.117						
180	0.267	0.255	0.245	0.235	0.226	0.218	0.210	0.203	0.184	0.173	0.163	0.155	0.147	0.140	0.134	0.125	0.118	0.111	0.105						
190	0.242	0.231	0.222	0.213	0.205	0.197	0.190	0.183	0.166	0.156	0.147	0.140	0.133	0.126	0.121	0.113	0.106	0.100	0.095						
200	0.220	0.210	0.202	0.193	0.186	0.179	0.172	0.166	0.151	0.142	0.134	0.127	0.120	0.115	0.109	0.102	0.096	0.091	0.086						
210	0.201	0.192	0.184	0.177	0.170	0.163	0.157	0.152	0.137	0.129	0.122	0.115	0.110	0.104	0.099	0.093	0.087	0.083	0.078						
220	0.184	0.176	0.169	0.162	0.155	0.149	0.144	0.139	0.126	0.118	0.111	0.106	0.100	0.095	0.091	0.085	0.080	0.075	0.071						
230	0.170	0.162	0.155	0.149	0.143	0.137	0.132	0.128	0.115	0.108	0.102	0.097	0.092	0.088	0.083	0.078	0.073	0.069	0.065						
240	0.157	0.149	0.143	0.137	0.132	0.127	0.122	0.118	0.106	0.100	0.094	0.089	0.085	0.081	0.077	0.072	0.068	0.064	0.060						
250	0.145	0.138	0.132	0.127	0.122	0.117	0.113	0.109	0.098	0.092	0.087	0.082	0.078	0.074	0.071	0.066	0.062	0.059	0.056						

**Table 8(b) Stress Reduction Factor,  $\chi$  for Column Buckling Class b**  
(Clauses 7.1.2.1 and 7.1.2.2)

$KL/r$ ↓	Yield Stress, $f_y$ (MPa)																								
	200	210	220	230	240	250	260	280	300	320	340	360	380	400	420	450	480	510	540						
10	1.000	1.000	1.000	1.000	1.000	1.000	1.000	1.000	1.000	1.000	1.000	1.000	1.000	1.000	1.000	1.000	1.000	1.000	1.000	1.000					
20	1.000	0.998	0.996	0.994	0.993	0.991	0.990	0.986	0.983	0.981	0.978	0.975	0.972	0.970	0.967	0.963	0.960	0.956	0.953	0.953					
30	0.963	0.961	0.958	0.955	0.953	0.950	0.948	0.943	0.938	0.933	0.929	0.924	0.920	0.915	0.911	0.904	0.898	0.892	0.886	0.886					
40	0.925	0.921	0.917	0.913	0.909	0.906	0.902	0.895	0.887	0.880	0.873	0.866	0.859	0.852	0.845	0.835	0.825	0.815	0.805	0.805					
50	0.883	0.877	0.872	0.866	0.861	0.855	0.850	0.839	0.829	0.818	0.808	0.798	0.787	0.777	0.767	0.752	0.737	0.722	0.708	0.708					
60	0.835	0.827	0.820	0.812	0.805	0.798	0.790	0.775	0.761	0.746	0.732	0.718	0.704	0.691	0.677	0.657	0.638	0.620	0.602	0.602					
70	0.781	0.771	0.761	0.751	0.742	0.732	0.722	0.703	0.685	0.667	0.649	0.632	0.615	0.599	0.584	0.561	0.540	0.520	0.502	0.502					
80	0.721	0.709	0.697	0.685	0.673	0.661	0.650	0.627	0.606	0.585	0.566	0.547	0.529	0.512	0.496	0.474	0.453	0.434	0.416	0.416					
90	0.657	0.643	0.629	0.615	0.602	0.589	0.576	0.552	0.530	0.508	0.488	0.470	0.452	0.436	0.421	0.400	0.380	0.363	0.346	0.346					
100	0.593	0.577	0.562	0.548	0.534	0.520	0.507	0.483	0.461	0.440	0.421	0.403	0.387	0.372	0.358	0.339	0.321	0.306	0.291	0.291					
110	0.531	0.515	0.500	0.485	0.471	0.458	0.445	0.422	0.401	0.381	0.364	0.348	0.333	0.319	0.306	0.289	0.274	0.260	0.247	0.247					
120	0.474	0.458	0.443	0.429	0.416	0.403	0.391	0.370	0.350	0.332	0.316	0.301	0.288	0.276	0.265	0.249	0.236	0.223	0.212	0.212					
130	0.423	0.408	0.394	0.380	0.368	0.356	0.345	0.325	0.307	0.291	0.276	0.263	0.251	0.240	0.230	0.217	0.204	0.194	0.184	0.184					
140	0.378	0.364	0.350	0.338	0.327	0.316	0.306	0.287	0.271	0.256	0.243	0.231	0.221	0.211	0.202	0.190	0.179	0.169	0.161	0.161					
150	0.339	0.325	0.313	0.302	0.291	0.281	0.272	0.255	0.241	0.227	0.215	0.205	0.195	0.186	0.178	0.167	0.158	0.149	0.142	0.142					
160	0.305	0.292	0.281	0.271	0.261	0.252	0.243	0.228	0.215	0.203	0.192	0.182	0.174	0.166	0.158	0.149	0.140	0.133	0.126	0.126					
170	0.275	0.264	0.253	0.244	0.235	0.227	0.219	0.205	0.193	0.182	0.172	0.163	0.155	0.148	0.142	0.133	0.125	0.118	0.112	0.112					
180	0.249	0.239	0.229	0.220	0.212	0.205	0.198	0.185	0.174	0.164	0.155	0.147	0.140	0.133	0.128	0.120	0.113	0.106	0.101	0.101					
190	0.227	0.217	0.208	0.200	0.193	0.186	0.179	0.168	0.157	0.148	0.140	0.133	0.127	0.121	0.115	0.108	0.102	0.096	0.091	0.091					
200	0.207	0.198	0.190	0.183	0.176	0.169	0.163	0.153	0.143	0.135	0.128	0.121	0.115	0.110	0.105	0.098	0.092	0.087	0.083	0.083					
210	0.190	0.182	0.174	0.167	0.161	0.155	0.149	0.140	0.131	0.123	0.117	0.110	0.105	0.100	0.096	0.090	0.084	0.080	0.075	0.075					
220	0.174	0.167	0.160	0.154	0.148	0.142	0.137	0.128	0.120	0.113	0.107	0.101	0.096	0.092	0.088	0.082	0.077	0.073	0.069	0.069					
230	0.161	0.154	0.147	0.141	0.136	0.131	0.126	0.118	0.111	0.104	0.098	0.093	0.088	0.084	0.080	0.075	0.071	0.067	0.063	0.063					
240	0.149	0.142	0.136	0.131	0.126	0.121	0.117	0.109	0.102	0.096	0.091	0.086	0.082	0.078	0.074	0.070	0.065	0.062	0.058	0.058					
250	0.138	0.132	0.126	0.121	0.117	0.112	0.108	0.101	0.095	0.089	0.084	0.080	0.076	0.072	0.069	0.064	0.060	0.057	0.054	0.054					



**Table 8(c) Stress Reduction Factor,  $\chi$  for Column Buckling Class c**  
(Clauses 7.1.2.1 and 7.1.2.2)

$KL/r$ ↓	Yield Stress, $f_y$ (MPa)																								
	200	210	220	230	240	250	260	280	300	320	340	360	380	400	420	450	480	510	540						
10	1.000	1.000	1.000	1.000	1.000	1.000	1.000	1.000	1.000	1.000	1.000	1.000	1.000	1.000	1.000	1.000	1.000	1.000	1.000						
20	0.999	0.997	0.994	0.992	0.990	0.987	0.985	0.981	0.976	0.972	0.968	0.964	0.961	0.957	0.953	0.948	0.943	0.938	0.933						
30	0.948	0.944	0.941	0.937	0.933	0.930	0.926	0.920	0.913	0.907	0.901	0.895	0.889	0.883	0.877	0.869	0.861	0.853	0.845						
40	0.896	0.891	0.885	0.880	0.875	0.870	0.866	0.856	0.847	0.838	0.829	0.820	0.812	0.803	0.795	0.783	0.771	0.760	0.748						
50	0.841	0.834	0.827	0.821	0.814	0.807	0.801	0.788	0.776	0.763	0.752	0.740	0.729	0.717	0.706	0.690	0.675	0.660	0.645						
60	0.783	0.774	0.765	0.757	0.748	0.740	0.732	0.716	0.700	0.685	0.670	0.656	0.642	0.628	0.615	0.596	0.578	0.561	0.544						
70	0.722	0.711	0.700	0.690	0.680	0.670	0.660	0.641	0.623	0.605	0.588	0.572	0.557	0.542	0.528	0.508	0.489	0.471	0.454						
80	0.659	0.646	0.634	0.622	0.611	0.600	0.589	0.568	0.548	0.529	0.512	0.495	0.479	0.464	0.450	0.430	0.412	0.395	0.379						
90	0.596	0.583	0.569	0.557	0.544	0.533	0.521	0.499	0.479	0.460	0.443	0.426	0.411	0.397	0.383	0.365	0.348	0.332	0.318						
100	0.536	0.522	0.508	0.495	0.483	0.471	0.459	0.438	0.418	0.400	0.384	0.368	0.354	0.341	0.328	0.311	0.296	0.282	0.269						
110	0.480	0.466	0.453	0.440	0.428	0.416	0.405	0.385	0.366	0.349	0.333	0.319	0.306	0.294	0.283	0.268	0.254	0.242	0.230						
120	0.430	0.416	0.403	0.391	0.379	0.368	0.358	0.339	0.321	0.306	0.291	0.278	0.267	0.256	0.246	0.232	0.220	0.209	0.199						
130	0.385	0.372	0.360	0.348	0.337	0.327	0.317	0.299	0.283	0.269	0.256	0.244	0.234	0.224	0.215	0.203	0.192	0.182	0.173						
140	0.346	0.333	0.322	0.311	0.301	0.291	0.282	0.266	0.251	0.238	0.227	0.216	0.206	0.197	0.189	0.178	0.168	0.160	0.152						
150	0.311	0.300	0.289	0.279	0.269	0.261	0.252	0.237	0.224	0.212	0.202	0.192	0.183	0.175	0.168	0.158	0.149	0.141	0.134						
160	0.281	0.270	0.260	0.251	0.242	0.234	0.227	0.213	0.201	0.190	0.180	0.172	0.164	0.156	0.150	0.141	0.133	0.126	0.120						
170	0.255	0.245	0.236	0.227	0.219	0.212	0.205	0.192	0.181	0.171	0.162	0.154	0.147	0.140	0.134	0.126	0.119	0.113	0.107						
180	0.232	0.223	0.214	0.206	0.199	0.192	0.186	0.174	0.164	0.155	0.147	0.139	0.133	0.127	0.121	0.114	0.107	0.102	0.096						
190	0.212	0.203	0.195	0.188	0.181	0.175	0.169	0.158	0.149	0.140	0.133	0.126	0.120	0.115	0.110	0.103	0.097	0.092	0.087						
200	0.194	0.186	0.179	0.172	0.166	0.160	0.154	0.144	0.136	0.128	0.121	0.115	0.110	0.105	0.100	0.094	0.089	0.084	0.079						
210	0.178	0.171	0.164	0.158	0.152	0.146	0.141	0.132	0.124	0.117	0.111	0.105	0.100	0.096	0.092	0.086	0.081	0.076	0.072						
220	0.164	0.157	0.151	0.145	0.140	0.135	0.130	0.122	0.114	0.108	0.102	0.097	0.092	0.088	0.084	0.079	0.074	0.070	0.066						
230	0.152	0.145	0.140	0.134	0.129	0.124	0.120	0.112	0.105	0.099	0.094	0.089	0.085	0.081	0.077	0.073	0.068	0.065	0.061						
240	0.141	0.135	0.129	0.124	0.120	0.115	0.111	0.104	0.098	0.092	0.087	0.082	0.078	0.075	0.071	0.067	0.063	0.060	0.056						
250	0.131	0.125	0.120	0.115	0.111	0.107	0.103	0.096	0.090	0.085	0.081	0.076	0.073	0.069	0.066	0.062	0.058	0.055	0.052						

**Table 8(d) Stress Reduction Factor,  $\chi$  for Column Buckling Class d**  
(Clauses 7.1.2.1 and 7.1.2.2)

$KL/r$ ↓	Yield Stress, $f_y$ (MPa)																			
	200	210	220	230	240	250	260	280	300	320	340	360	380	400	420	450	480	510	540	
10	1.000	1.000	1.000	1.000	1.000	1.000	1.000	1.000	1.000	1.000	1.000	1.000	1.000	1.000	1.000	1.000	1.000	1.000	1.000	1.000
20	0.999	0.995	0.991	0.988	0.984	0.980	0.977	0.970	0.964	0.958	0.952	0.946	0.940	0.935	0.930	0.922	0.915	0.908	0.901	0.891
30	0.922	0.916	0.911	0.906	0.901	0.896	0.891	0.881	0.872	0.863	0.855	0.847	0.839	0.831	0.823	0.813	0.802	0.792	0.782	0.772
40	0.848	0.841	0.834	0.828	0.821	0.815	0.808	0.796	0.784	0.773	0.762	0.751	0.741	0.731	0.721	0.707	0.694	0.681	0.668	0.658
50	0.777	0.768	0.760	0.752	0.744	0.736	0.728	0.713	0.699	0.685	0.672	0.659	0.647	0.635	0.624	0.608	0.592	0.577	0.563	0.553
60	0.707	0.697	0.687	0.678	0.668	0.659	0.651	0.634	0.617	0.602	0.587	0.573	0.560	0.547	0.535	0.517	0.501	0.486	0.471	0.461
70	0.640	0.629	0.618	0.607	0.597	0.587	0.578	0.559	0.542	0.526	0.510	0.496	0.482	0.469	0.456	0.439	0.423	0.408	0.394	0.384
80	0.576	0.564	0.553	0.542	0.531	0.521	0.511	0.492	0.474	0.458	0.442	0.428	0.414	0.402	0.390	0.373	0.358	0.344	0.330	0.320
90	0.517	0.505	0.493	0.482	0.471	0.461	0.451	0.432	0.415	0.399	0.384	0.370	0.357	0.345	0.334	0.319	0.304	0.292	0.280	0.270
100	0.464	0.451	0.440	0.428	0.418	0.408	0.398	0.380	0.363	0.348	0.334	0.321	0.309	0.298	0.288	0.274	0.261	0.249	0.239	0.229
110	0.416	0.404	0.392	0.381	0.371	0.361	0.352	0.335	0.319	0.305	0.292	0.281	0.270	0.259	0.250	0.237	0.226	0.215	0.206	0.196
120	0.373	0.361	0.350	0.340	0.330	0.321	0.313	0.297	0.282	0.269	0.257	0.246	0.236	0.227	0.219	0.207	0.197	0.187	0.179	0.169
130	0.336	0.325	0.314	0.305	0.295	0.287	0.279	0.264	0.251	0.239	0.228	0.218	0.209	0.200	0.193	0.182	0.173	0.164	0.157	0.147
140	0.303	0.292	0.283	0.274	0.265	0.257	0.250	0.236	0.224	0.213	0.203	0.194	0.185	0.178	0.171	0.161	0.153	0.145	0.138	0.128
150	0.274	0.264	0.255	0.247	0.239	0.231	0.224	0.212	0.201	0.190	0.181	0.173	0.165	0.159	0.152	0.144	0.136	0.129	0.123	0.113
160	0.249	0.240	0.231	0.223	0.216	0.209	0.203	0.191	0.181	0.171	0.163	0.155	0.149	0.142	0.137	0.129	0.122	0.116	0.110	0.100
170	0.227	0.218	0.210	0.203	0.196	0.190	0.184	0.173	0.164	0.155	0.147	0.140	0.134	0.128	0.123	0.116	0.110	0.104	0.099	0.089
180	0.207	0.199	0.192	0.185	0.179	0.173	0.167	0.157	0.149	0.141	0.134	0.127	0.122	0.116	0.111	0.105	0.099	0.094	0.089	0.079
190	0.190	0.183	0.176	0.169	0.164	0.158	0.153	0.144	0.136	0.128	0.122	0.116	0.111	0.106	0.101	0.095	0.090	0.085	0.081	0.071
200	0.175	0.168	0.162	0.156	0.150	0.145	0.140	0.132	0.124	0.118	0.112	0.106	0.101	0.097	0.093	0.087	0.082	0.078	0.074	0.064
210	0.161	0.155	0.149	0.143	0.138	0.134	0.129	0.121	0.114	0.108	0.102	0.097	0.093	0.089	0.085	0.080	0.075	0.071	0.068	0.058
220	0.149	0.143	0.138	0.133	0.128	0.123	0.119	0.112	0.105	0.100	0.094	0.090	0.086	0.082	0.078	0.074	0.069	0.066	0.062	0.052
230	0.138	0.133	0.128	0.123	0.118	0.114	0.110	0.104	0.097	0.092	0.087	0.083	0.079	0.075	0.072	0.068	0.064	0.061	0.058	0.048
240	0.129	0.123	0.119	0.114	0.110	0.106	0.103	0.096	0.090	0.085	0.081	0.077	0.073	0.070	0.067	0.063	0.059	0.056	0.053	0.043
250	0.120	0.115	0.110	0.106	0.102	0.099	0.095	0.089	0.084	0.079	0.075	0.071	0.068	0.065	0.062	0.058	0.055	0.052	0.049	0.039

**Table 9(a) Design Compressive Stress,  $f_{cd}$  (MPa) for Column Buckling Class a**  
(Clause 7.1.2.1)

$KL/r$ ↓	Yield Stress, $f_y$ (MPa)																								
	200	210	220	230	240	250	260	280	300	320	340	360	380	400	420	450	480	510	540						
10	182	191	200	213	218	227	236	255	273	291	309	327	345	364	382	409	436	464	491						
20	182	191	200	208	217	226	235	252	270	287	305	322	339	357	374	400	425	451	476						
30	178	186	195	203	212	220	229	245	262	279	295	311	328	344	360	384	408	431	454						
40	173	181	189	197	205	213	221	237	253	268	283	298	313	328	342	363	384	405	425						
50	168	176	183	191	198	205	213	227	241	255	268	281	294	306	318	336	352	368	383						
60	162	169	175	182	189	195	202	214	226	237	248	258	268	278	286	299	310	320	329						
70	154	160	166	171	177	182	188	197	207	215	223	230	237	243	249	256	263	268	274						
80	144	149	154	158	163	167	171	178	184	190	195	199	204	207	210	215	219	222	225						
90	133	137	140	143	146	149	152	157	161	164	168	170	173	175	177	179	182	184	185						
100	120	123	125	128	130	132	133	136	139	141	143	145	146	148	149	151	152	153	154						
110	107	109	111	112	114	115	116	118	120	121	123	124	125	126	127	128	129	129	130						
120	95.5	96.7	97.9	98.9	100	101	101	103	104	105	106	107	107	108	109	109	110	110	111						
130	84.6	85.5	86.3	87	87.7	88.3	88.8	89.8	90.6	91.3	92.0	92.5	93.0	93.5	93.9	94.4	94.9	95.3	95.7						
140	75.2	75.8	76.4	76.9	77.4	77.8	78.2	78.9	79.5	80.0	80.5	80.9	81.3	81.6	81.9	82.3	82.6	83.0	83.2						
150	67.0	67.4	67.9	68.2	68.6	68.9	69.2	69.7	70.2	70.6	70.9	71.2	71.5	71.8	72.0	72.3	72.6	72.9	73.1						
160	59.9	60.3	60.6	60.9	61.1	61.4	61.6	62.0	62.4	62.7	62.9	63.2	63.4	63.6	63.8	64.0	64.3	64.5	64.6						
170	53.8	54.1	54.3	54.6	54.8	55.0	55.1	55.5	55.7	56.0	56.2	56.4	56.6	56.7	56.9	57.1	57.3	57.4	57.6						
180	48.6	48.8	49.0	49.2	49.3	49.5	49.6	49.9	50.1	50.3	50.5	50.6	50.8	50.9	51.0	51.2	51.3	51.5	51.6						
190	44.0	44.2	44.3	44.5	44.6	44.7	44.9	45.1	45.3	45.4	45.6	45.7	45.8	45.9	46.0	46.2	46.3	46.4	46.5						
200	40.0	40.2	40.3	40.4	40.5	40.7	40.7	40.9	41.1	41.2	41.3	41.4	41.5	41.6	41.7	41.8	41.9	42.0	42.1						
210	36.6	36.7	36.8	36.9	37.0	37.1	37.2	37.3	37.4	37.6	37.7	37.8	37.8	37.9	38.0	38.1	38.2	38.3	38.3						
220	33.5	33.6	33.7	33.8	33.9	34.0	34.0	34.2	34.3	34.4	34.5	34.5	34.6	34.7	34.7	34.8	34.9	35.0	35.0						
230	30.8	30.9	31.0	31.1	31.2	31.2	31.3	31.4	31.5	31.6	31.6	31.7	31.8	31.8	31.9	31.9	32.0	32.1	32.1						
240	28.5	28.5	28.6	28.7	28.7	28.8	28.8	28.9	29.0	29.1	29.1	29.2	29.3	29.3	29.4	29.4	29.5	29.5	29.6						
250	26.3	26.4	26.5	26.5	26.6	26.6	26.7	26.7	26.8	26.9	26.9	27.0	27.0	27.1	27.1	27.2	27.2	27.3	27.3						

**Table 9(b) Design Compressive Stress,  $f_{cd}$  (MPa) for Column Buckling Class b**  
(Clause 7.1.2.1)

$KL/r$ ↓	Yield Stress, $f_y$ (MPa)																			
	200	210	220	230	240	250	260	280	300	320	340	360	380	400	420	450	480	510	540	
10	182	191	200	209	218	227	236	255	273	291	309	327	345	364	382	409	436	464	491	
20	182	190	199	208	217	225	234	251	268	285	302	319	336	353	369	394	419	443	468	
30	175	183	192	200	208	216	224	240	256	271	287	302	318	333	348	370	392	414	435	
40	168	176	183	191	198	206	213	228	242	256	270	283	297	310	323	342	360	378	395	
50	161	167	174	181	188	194	201	214	226	238	250	261	272	283	293	308	322	335	347	
60	152	158	164	170	176	181	187	197	207	217	226	235	243	251	259	269	279	287	295	
70	142	147	152	157	162	166	171	179	187	194	201	207	213	218	223	230	236	241	246	
80	131	135	139	143	147	150	154	160	165	170	175	179	183	186	190	194	198	201	204	
90	120	123	126	129	131	134	136	141	144	148	151	154	156	159	161	163	166	168	170	
100	108	110	112	114	116	118	120	123	126	128	130	132	134	135	137	139	140	142	143	
110	96.5	98.3	100	101	103	104	105	107	109	111	112	114	115	116	117	118	119	121	121	
120	86.2	87.5	88.6	89.7	90.7	91.7	92.5	94.1	95.4	96.6	97.7	98.6	100	100	101	102	103	104	104	
130	76.9	77.8	78.7	79.5	80.3	81.0	81.6	82.7	83.7	84.6	85.4	86.1	86.8	87.3	87.9	88.6	89.2	89.8	90.3	
140	68.7	69.4	70.1	70.7	71.3	71.8	72.3	73.1	73.9	74.6	75.2	75.7	76.2	76.6	77.1	77.6	78.1	78.5	78.9	
150	61.6	62.1	62.6	63.1	63.6	64.0	64.3	65.0	65.6	66.1	66.6	67.0	67.4	67.7	68.1	68.5	68.9	69.2	69.5	
160	55.4	55.8	56.2	56.6	56.9	57.3	57.5	58.1	58.5	59.0	59.3	59.7	60.0	60.3	60.5	60.9	61.2	61.5	61.7	
170	50.0	50.3	50.7	51.0	51.2	51.5	51.7	52.2	52.5	52.9	53.2	53.5	53.7	53.9	54.1	54.4	54.7	54.9	55.1	
180	45.3	45.6	45.9	46.1	46.3	46.5	46.7	47.1	47.4	47.7	47.9	48.1	48.3	48.5	48.7	48.9	49.2	49.3	49.5	
190	41.2	41.5	41.7	41.9	42.1	42.2	42.4	42.7	42.9	43.2	43.4	43.6	43.7	43.9	44.0	44.2	44.4	44.6	44.7	
200	37.6	37.8	38.0	38.2	38.3	38.5	38.6	38.9	39.1	39.3	39.5	39.6	39.8	39.9	40.0	40.2	40.3	40.5	40.6	
210	34.5	34.7	34.8	35.0	35.1	35.2	35.3	35.5	35.7	35.9	36.0	36.2	36.3	36.4	36.5	36.6	36.8	36.9	37.0	
220	31.7	31.9	32.0	32.1	32.2	32.3	32.4	32.6	32.8	32.9	33.0	33.1	33.2	33.3	33.4	33.6	33.7	33.8	33.9	
230	29.2	29.4	29.5	29.6	29.7	29.8	29.9	30.0	30.1	30.3	30.4	30.5	30.6	30.7	30.7	30.8	30.9	31.0	31.1	
240	27.1	27.2	27.3	27.3	27.4	27.5	27.6	27.7	27.8	27.9	28.0	28.1	28.2	28.3	28.3	28.4	28.5	28.6	28.7	
250	25.1	25.2	25.3	25.3	25.4	25.5	25.6	25.7	25.8	25.9	26.0	26.0	26.1	26.2	26.2	26.3	26.4	26.5	26.5	

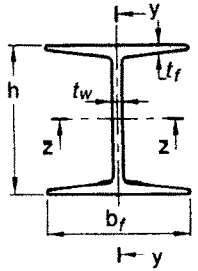
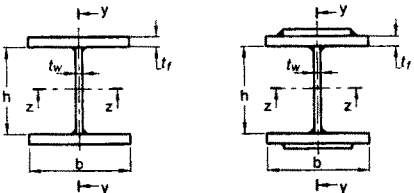

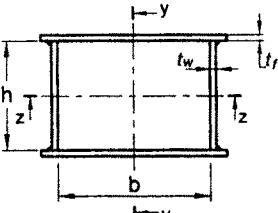
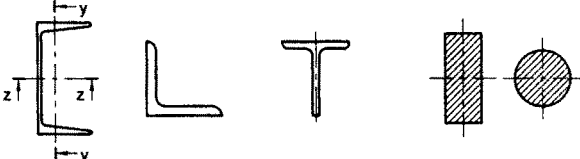
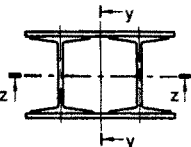
**Table 9(c) Design Compressive Stress,  $f_{cd}$  (MPa) for Column Buckling Class c**  
(Clause 7.1.2.1)

$KL/r$ ↓	Yield Stress, $f_y$ (MPa)																			
	200	210	220	230	240	250	260	280	300	320	340	360	380	400	420	450	480	510	540	
10	182	191	200	209	218	227	236	255	273	291	309	327	345	364	382	409	436	464	491	
20	182	190	199	207	216	224	233	250	266	283	299	316	332	348	364	388	412	435	458	
30	172	180	188	196	204	211	219	234	249	264	278	293	307	321	335	355	376	395	415	
40	163	170	177	184	191	198	205	218	231	244	256	268	280	292	304	320	337	352	367	
50	153	159	165	172	178	183	189	201	212	222	232	242	252	261	270	282	295	306	317	
60	142	148	153	158	163	168	173	182	191	199	207	215	222	228	235	244	252	260	267	
70	131	136	140	144	148	152	156	163	170	176	182	187	192	197	202	208	213	218	223	
80	120	123	127	130	133	136	139	145	149	154	158	162	165	169	172	176	180	183	186	
90	108	111	114	116	119	121	123	127	131	134	137	140	142	144	146	149	152	154	156	
100	97.5	100	102	104	105	107	109	112	114	116	119	120	122	124	125	127	129	131	132	
110	87.3	89.0	90.5	92.0	93.3	94.6	95.7	97.9	100	102	103	104	106	107	108	110	111	112	113	
120	78.2	79.4	80.6	81.7	82.7	83.7	84.6	86.2	87.6	88.9	90.1	91.1	92.1	93.0	93.8	94.9	95.9	96.8	97.6	
130	70.0	71.0	71.9	72.8	73.5	74.3	75.0	76.2	77.3	78.3	79.2	80.0	80.7	81.4	82.0	82.9	83.6	84.3	84.9	
140	62.9	63.6	64.4	65.0	65.6	66.2	66.7	67.7	68.6	69.3	70.0	70.7	71.2	71.8	72.3	72.9	73.5	74.1	74.6	
150	56.6	57.2	57.8	58.3	58.8	59.2	59.7	60.4	61.1	61.7	62.3	62.8	63.3	63.7	64.1	64.6	65.1	65.5	65.9	
160	51.1	51.6	52.1	52.5	52.9	53.3	53.6	54.2	54.8	55.3	55.7	56.1	56.5	56.9	57.2	57.6	58.0	58.4	58.7	
170	46.4	46.8	47.1	47.5	47.8	48.1	48.4	48.9	49.3	49.8	50.1	50.5	50.8	51.1	51.3	51.7	52.0	52.3	52.6	
180	42.2	42.5	42.8	43.1	43.4	43.6	43.9	44.3	44.7	45.0	45.3	45.6	45.8	46.1	46.3	46.6	46.9	47.1	47.3	
190	38.5	38.8	39.0	39.3	39.5	39.7	39.9	40.3	40.6	40.9	41.1	41.4	41.6	41.8	42.0	42.2	42.5	42.7	42.9	
200	35.3	35.5	35.7	35.9	36.1	36.3	36.5	36.8	37.0	37.3	37.5	37.7	37.9	38.1	38.2	38.4	38.6	38.8	39.0	
210	32.4	32.6	32.8	33.0	33.1	33.3	33.4	33.7	33.9	34.1	34.3	34.5	34.7	34.8	34.9	35.1	35.3	35.4	35.6	
220	29.9	30.1	30.2	30.4	30.5	30.6	30.8	31.0	31.2	31.4	31.5	31.7	31.8	31.9	32.1	32.2	32.4	32.5	32.6	
230	27.6	27.8	27.9	28.0	28.2	28.3	28.4	28.6	28.8	28.9	29.1	29.2	29.3	29.4	29.5	29.7	29.8	29.9	30.0	
240	25.6	25.7	25.9	26.0	26.1	26.2	26.3	26.4	26.6	26.7	26.9	27.0	27.1	27.2	27.3	27.4	27.5	27.6	27.7	
250	23.8	23.9	24.0	24.1	24.2	24.3	24.4	24.5	24.7	24.8	24.9	25.0	25.1	25.2	25.3	25.4	25.5	25.6	25.7	







Table 9(d) Design Compressive Stress,  $f_{cd}$  (MPa) for Column Buckling Class d  
(Clause 7.1.2.1)

KL/r ↓	Yield Stress, $f_y$ (MPa)																			
	200	210	220	230	240	250	260	280	300	320	340	360	380	400	420	450	480	510	540	
10	182	191	200	209	218	227	236	255	273	291	309	327	345	364	382	409	436	464	491	
20	182	190	198	206	215	223	231	247	263	279	294	310	325	340	355	377	399	421	442	
30	168	175	182	189	197	204	211	224	238	251	264	277	290	302	314	332	350	367	384	
40	154	161	167	173	179	185	191	203	214	225	235	246	256	266	275	289	303	316	328	
50	141	147	152	157	162	167	172	182	191	199	208	216	224	231	238	249	258	268	277	
60	129	133	137	142	146	150	154	161	168	175	182	188	193	199	204	212	219	225	231	
70	116	120	124	127	130	133	137	142	148	153	158	162	167	171	174	180	184	189	193	
80	105	108	111	113	116	118	121	125	129	133	137	140	143	146	149	153	156	159	162	
90	94.1	96.4	98.6	101	103	105	107	110	113	116	119	121	123	126	128	130	133	135	137	
100	84.3	86.2	87.9	89.6	91.1	92.6	94.0	96.7	99.1	101	103	105	107	108	110	112	114	116	117	
110	75.6	77.0	78.4	79.7	81.0	82.1	83.2	85.3	87.1	88.8	90.4	91.8	93.1	94.4	95.5	97.1	98.5	100	101	
120	67.8	69.0	70.1	71.1	72.1	73.0	73.9	75.5	77.0	78.3	79.5	80.6	81.7	82.6	83.5	84.7	85.8	86.9	87.8	
130	61.0	62.0	62.8	63.7	64.5	65.2	65.9	67.2	68.3	69.4	70.4	71.2	72.1	72.8	73.5	74.5	75.4	76.2	76.9	
140	55.0	55.8	56.5	57.2	57.8	58.4	59.0	60.0	61.0	61.8	62.6	63.3	64.0	64.6	65.2	66.0	66.7	67.3	67.9	
150	49.8	50.4	51.0	51.6	52.1	52.6	53.1	53.9	54.7	55.4	56.0	56.6	57.2	57.7	58.1	58.8	59.3	59.9	60.4	
160	45.2	45.7	46.2	46.7	47.1	47.5	47.9	48.6	49.3	49.9	50.4	50.9	51.3	51.7	52.1	52.7	53.1	53.6	54.0	
170	41.2	41.6	42.1	42.4	42.8	43.1	43.5	44.1	44.6	45.1	45.5	45.9	46.3	46.7	47.0	47.4	47.8	48.2	48.6	
180	37.7	38.0	38.4	38.7	39.0	39.3	39.6	40.1	40.5	41.0	41.3	41.7	42.0	42.3	42.6	43.0	43.3	43.6	43.9	
190	34.5	34.9	35.2	35.4	35.7	35.9	36.2	36.6	37.0	37.4	37.7	38.0	38.2	38.5	38.7	39.1	39.4	39.6	39.9	
200	31.8	32.0	32.3	32.5	32.8	33.0	33.2	33.6	33.9	34.2	34.5	34.7	35.0	35.2	35.4	35.7	35.9	36.2	36.4	
210	29.3	29.6	29.8	30.0	30.2	30.4	30.5	30.9	31.2	31.4	31.7	31.9	32.1	32.3	32.5	32.7	32.9	33.1	33.3	
220	27.1	27.3	27.5	27.7	27.9	28.0	28.2	28.5	28.7	29.0	29.2	29.4	29.6	29.7	29.9	30.1	30.3	30.5	30.6	
230	25.2	25.3	25.5	25.7	25.8	26.0	26.1	26.4	26.6	26.8	27.0	27.1	27.3	27.5	27.6	27.8	27.9	28.1	28.2	
240	23.4	23.6	23.7	23.9	24.0	24.1	24.2	24.5	24.7	24.8	25.0	25.2	25.3	25.4	25.5	25.7	25.9	26.0	26.1	
250	21.8	22.0	22.1	22.2	22.3	22.5	22.6	22.8	22.9	23.1	23.2	23.4	23.5	23.6	23.7	23.9	24.0	24.1	24.2	

**Table 10 Buckling Class of Cross-Sections**  
(Clause 7.1.2.2)

Cross-Section (1)	Limits (2)	Buckling About Axis (3)	Buckling Class (4)
<p>Rolled I-Sections</p> 	<p><math>h/b_f &gt; 1.2</math> : <math>t_f \leq 40</math> mm</p> <p><math>40 \leq t_f &lt; 100</math> mm</p> <hr/> <p><math>h/b_f \leq 1.2</math> : <math>t_f \leq 100</math> mm</p> <p><math>t_f &gt; 100</math> mm</p>	<p>z-z y-y</p> <hr/> <p>z-z y-y</p> <hr/> <p>z-z y-y</p>	<p>a b</p> <hr/> <p>b c</p> <hr/> <p>d d</p>
<p>Welded I-Section</p> 	<p><math>t_f \leq 40</math> mm</p> <hr/> <p><math>t_f &gt; 40</math> mm</p>	<p>z-z y-y</p> <hr/> <p>z-z y-y</p>	<p>b c</p> <hr/> <p>c d</p>
<p>Hollow Section</p> 	<p>Hot rolled</p> <hr/> <p>Cold formed</p>	<p>Any</p> <hr/> <p>Any</p>	<p>a</p> <hr/> <p>b</p>
<p>Welded Box Section</p> 	<p>Generally (except as below)</p> <hr/> <p>Thick welds and</p> <p><math>b/t_f &lt; 30</math></p> <p><math>h/t_w &lt; 30</math></p>	<p>Any</p> <hr/> <p>z-z</p> <p>y-y</p>	<p>b</p> <hr/> <p>c</p> <p>c</p>
<p>Channel, Angle, T and Solid Sections</p> 		<p>Any</p>	<p>c</p>
<p>Built-up Member</p> 		<p>Any</p>	<p>c</p>

**Table 11 Effective Length of Prismatic Compression Members**  
(Clause 7.2.2)

Boundary Conditions				Schematic Representation	Effective Length
At One End		At the Other End			
Translation (1)	Rotation (2)	Translation (3)	Rotation (4)		
Restrained	Restrained	Free	Free		2.0L
Free	Restrained	Free	Restrained		
Restrained	Free	Restrained	Free		1.0L
Restrained	Restrained	Free	Restrained		1.2L
Restrained	Restrained	Restrained	Free		0.8L
Restrained	Restrained	Restrained	Restrained		0.65L

NOTE —  $L$  is the unsupported length of the compression member (see 7.2.1).



### 7.3 Design Details

#### 7.3.1 Thickness of Plate Elements

Classification of members on the basis of thickness of constituent plate elements shall satisfy the width-thickness ratio requirements specified in Table 2.

#### 7.3.2 Effective Sectional Area, $A_e$

Except as modified in 3.7.2 (Class 4), the gross sectional area shall be taken as the effective sectional area for all compression members fabricated by welding, bolting and riveting so long as the section is semi-compact or better. Holes not fitted with rivets, bolts or pins shall be deducted from gross area to calculate effective sectional area.

#### 7.3.3 Eccentricity for Stanchions and Columns

**7.3.3.1** For the purpose of determining the stress in a stanchion or column section, the beam reactions or similar loads shall be assumed to be applied at an eccentricity of 100 mm from the face of the section or at the centre of bearing whichever dimension gives the greater eccentricity, and with the exception of the following two cases:

- a) In the case of cap connection, the load shall be assumed to be applied at the face of the column or stanchion section or at the edge of packing, if used towards the span of the beam.
- b) In the case of a roof truss bearing on a cap, no eccentricity be taken for simple bearings without connections capable of developing any appreciable moment. In case of web member connection with face, actual eccentricity is to be considered.

**7.3.3.2** In continuous columns, the bending moments due to eccentricities of loading on the columns at any floor may be divided equally between the columns above and below that floor level, provided that the moment of inertia of one column section, divided by its effective length does not exceed 1.5 times the corresponding value of the other column. Where this ratio is exceeded, the bending moment shall be divided in proportion to the moment of inertia of the column sections divided by their respective effective lengths.

#### 7.3.4 Splices

**7.3.4.1** Where the ends of compression members are prepared for bearing over the whole area, they shall be spliced to hold the connected members accurately in position, and to resist bending or tension, if present. Such splices should maintain the intended member stiffness about each axis. Splices should be located as close to the point of inflection as possible. Otherwise their capacity should be adequate to carry magnified moment

(see 9.3.2.2). The ends of compression members faced for bearing shall invariably be machined to ensure perfect contact of surfaces in bearing.

**7.3.4.2** Where such members are not faced for complete bearing, the splices shall be designed to transmit all the forces to which the members are subjected.

**7.3.4.3** Wherever possible, splices shall be proportioned and arranged so that the centroidal axis of the splice coincides as nearly as possible with the centroidal axes of the members being jointed, in order to avoid eccentricity; but where eccentricity is present in the joint, the resulting stress shall be accounted for.

### 7.4 Column Bases

#### 7.4.1 General

Column bases should have sufficient stiffness and strength to transmit axial force, bending moments and shear forces at the base of the columns to their foundation without exceeding the load carrying capacity of the supports. Anchor bolts and shear keys should be provided wherever necessary. Shear resistance at the proper contact surface between steel base and concrete/grout may be calculated using a friction coefficient of 0.45.

The nominal bearing pressure between the base plate and the support below may be determined on the basis of linearly varying distribution of pressure. The maximum bearing pressure should not exceed the bearing strength equal to  $0.6f_{ck}$ , where  $f_{ck}$  is the smaller of characteristic cube strength of concrete or bedding material.

**7.4.1.1** If the size of the base plate is larger than that required to limit the bearing pressure on the base support, an equal projection  $c$  of the base plate beyond the face of the column and gusset may be taken as effective in transferring the column load as given in Fig. 9, such that bearing pressure on the effective area does not exceed bearing capacity of concrete base.

#### 7.4.2 Gusseted Bases

For stanchion with gusseted bases, the gusset plates, angle cleats, stiffeners, fastenings, etc, in combination with the bearing area of the shaft, shall be sufficient to take the loads, bending moments and reactions to the base plate without exceeding specified strength. All the bearing surfaces shall be machined to ensure perfect contact.

**7.4.2.1** Where the ends of the column shaft and the gusset plates are not faced for complete bearing, the weldings, fastenings connecting them to the base plate shall be sufficient to transmit all the forces to which the base is subjected.

**7.4.2.2 Column and base plate connections**

Where the end of the column is connected directly to the base plate by means of full penetration butt welds, the connection shall be deemed to transmit to the base all the forces and moments to which the column is subjected.

**7.4.3 Slab Bases**

Columns with slab bases need not be provided with gussets, but sufficient fastenings shall be provided to retain the parts securely in place and to resist all moments and forces, other than direct compression, including those arising during transit, unloading and erection.

**7.4.3.1** The minimum thickness,  $t_s$ , of rectangular slab bases, supporting columns under axial compression shall be

$$t_s = \sqrt{2.5 w (a^2 - 0.3b^2) \gamma_{m0} / f_y} > t_f$$

where

- $w$  = uniform pressure from below on the slab base under the factored load axial compression;
- $a, b$  = larger and smaller projection, respectively of the slab base beyond the rectangle circumscribing the column; and
- $t_f$  = flange thickness of compression member.

When only the effective area of the base plate is used as in 7.4.1.1,  $c^2$  may be used in the above equation (see Fig. 9) instead of  $(a^2 - 0.3b^2)$ .

**7.4.3.2** When the slab does not distribute the column load uniformly, due to eccentricity of the load etc, special calculation shall be made to show that the base is adequate to resist the moment due to the non-uniform pressure from below.

**7.4.3.3** Bases for bearing upon concrete or masonry need not be machined on the underside.

**7.4.3.4** In cases where the cap or base is fillet welded directly to the end of the column without boring and shouldering, the contact surfaces shall be machined to give a perfect bearing and the welding shall be sufficient to transmit the forces as required in 7.4.3. Where full strength butt welds are provided, machining of contact surfaces is not required.

**7.5 Angle Struts**

**7.5.1 Single Angle Struts**

The compression in single angles may be transferred either concentrically to its centroid through end gusset or eccentrically by connecting one of its legs to a gusset or adjacent member.

**7.5.1.1 Concentric loading**

When a single angle is concentrically loaded in compression, the design strength may be evaluated using 7.1.2.

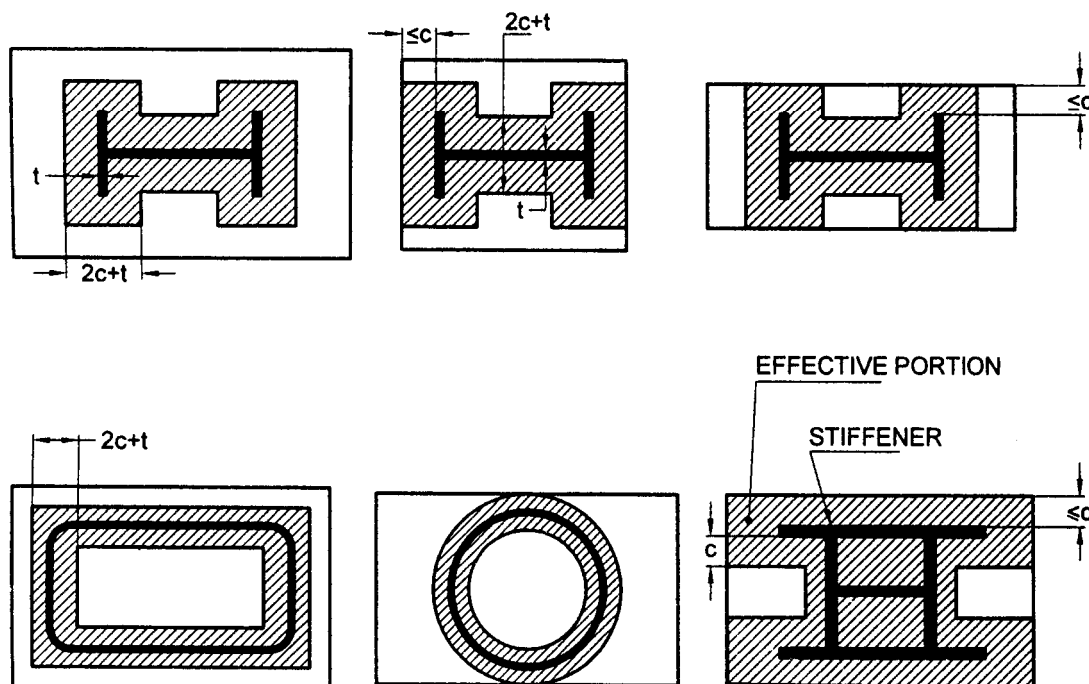


FIG. 9 EFFECTIVE AREA OF A BASE PLATE

7.5.1.2 Loaded through one leg

The flexural torsional buckling strength of single angle loaded in compression through one of its legs may be evaluated using the equivalent slenderness ratio,  $\lambda_e$ , as given below:

$$\lambda_e = \sqrt{k_1 + k_2 \lambda_{vv}^2 + k_3 \lambda_\phi^2}$$

where

$k_1, k_2, k_3$  = constants depending upon the end condition, as given in Table 12,

$$\lambda_{vv} = \frac{\left(\frac{l}{r_{vv}}\right)}{\epsilon \sqrt{\frac{\pi^2 \epsilon}{250}}} \text{ and } \lambda_\phi = \frac{(b_1 + b_2)/2t}{\epsilon \sqrt{\frac{\pi^2 \epsilon}{250}}}$$

where

- $l$  = centre-to-centre length of the supporting member,
- $r_{vv}$  = radius of gyration about the minor axis,
- $b_1, b_2$  = width of the two legs of the angle,
- $t$  = thickness of the leg, and
- $\epsilon$  = yield stress ratio  $(250/f_y)^{0.5}$ .

Table 12 Constants  $k_1, k_2$  and  $k_3$

Sl No.	No. of Bolts at Each End Connection	Gusset/Connecting Member Fixity <sup>1)</sup>	$k_1$	$k_2$	$k_3$
(1)	(2)	(3)	(4)	(5)	(6)
i)	$\geq 2$	Fixed	0.20	0.35	20
		Hinged			
ii)	1	Fixed	0.75	0.35	20
		Hinged			

<sup>1)</sup> Stiffness of in-plane rotational restraint provided by the gusset/connecting member.  
For partial restraint, the  $\lambda_e$  can be interpolated between the  $\lambda_e$  results for fixed and hinged cases.

7.5.2 Double Angle Struts

7.5.2.1 For double angle discontinuous struts, connected back to back, on opposite sides of the gusset or a section, by not less than two bolts or rivets in line along the angles at each end, or by the equivalent in welding, the load may be regarded as applied axially. The effective length,  $KL$ , in the plane of end gusset shall be taken as between 0.7 and 0.85 times the distance between intersections, depending on the degree of the restraint provided. The effective length,  $KL$ , in the plane perpendicular to that of the end gusset, shall be taken as equal to the distance between centres of intersections. The calculated average compressive

stress shall not exceed the values based on 7.1.2. The angles shall be connected together over their lengths so as to satisfy the requirements of 7.8 and 10.2.5.

7.5.2.2 Double angle discontinuous struts connected back-to-back, to one side of a gusset or section by one or more bolts or rivets in each angle, or by the equivalent in welding, shall be designed in accordance with 7.5.1 and the angles shall be connected together over their lengths so as to satisfy the requirements of 7.8 and 10.2.5.

7.5.3 Continuous Members

Double angle continuous struts such as those forming the flanges, chords or ties of trusses or trussed girders, or the legs of towers shall be designed as axially loaded compression members, and the effective length shall be taken in accordance with 7.2.4.

7.5.4 Combined Stresses

In addition to axial loads, if the struts carry loads which cause transverse bending, the combined bending and axial stresses shall be checked in accordance with 9.3. For determining the permissible axial and bending stresses, the effective length shall be taken in accordance with the 7.2 and 8.3.

7.6 Laced Columns

7.6.1 General

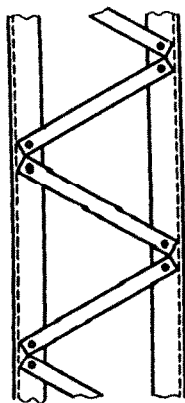
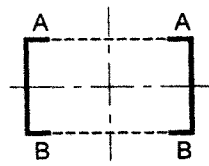
7.6.1.1 Members comprising two main components laced and tied, should where practicable, have a radius of gyration about the axis perpendicular to the plane of lacing not less than the radius of gyration about the axis parallel to the plane of lacing (see Fig. 10A and 10B).

7.6.1.2 As far as practicable, the lacing system shall be uniform throughout the length of the column.

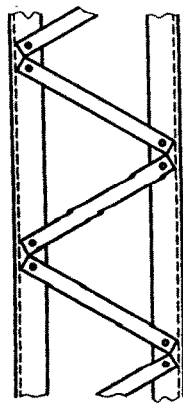
7.6.1.3 Except for tie plates as specified in 7.7, double laced systems (see Fig. 10B) and single laced systems (see Fig. 10A) on opposite sides of the main components shall not be combined with cross members (ties) perpendicular to the longitudinal axis of the strut (see Fig. 10C), unless all forces resulting from deformation of the strut members are calculated and provided for in the design of lacing and its fastenings.

7.6.1.4 Single laced systems, on opposite faces of the components being laced together shall preferably be in the same direction so that one is the shadow of the other, instead of being mutually opposed in direction.

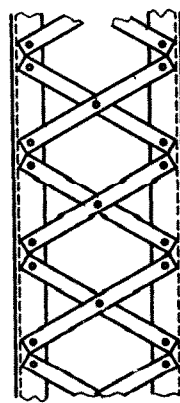
7.6.1.5 The effective slenderness ratio,  $(KL/r)_e$ , of laced columns shall be taken as 1.05 times the  $(KL/r)_0$ , the actual maximum slenderness ratio, in order to account for shear deformation effects.



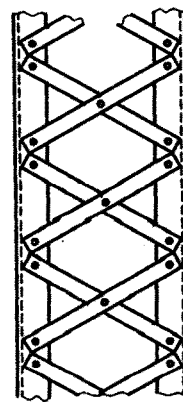
LACING ON  
FACE A



LACING ON  
FACE B



LACING ON  
FACE A



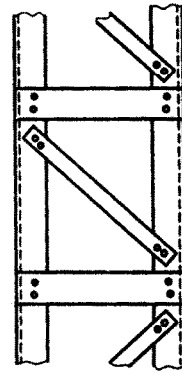
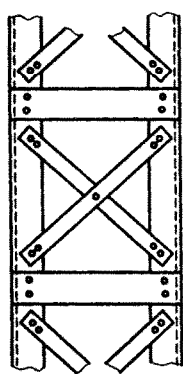
LACING ON  
FACE B

PREFFERED LACING  
ARRANGEMENT

10A Single Laced System

PREFFERED LACING  
ARRANGEMENT

10B Double Laced System



10C Double Laced and Single Laced System Combined with Cross Numbers

FIG. 10 LACED COLUMNS

### 7.6.2 Width of Lacing Bars

In bolted/riveted construction, the minimum width of lacing bars shall be three times the nominal diameter of the end bolt/rivet.

### 7.6.3 Thickness of Lacing Bars

The thickness of flat lacing bars shall not be less than one-fortieth of its effective length for single lacings and one-sixtieth of the effective length for double lacings.

**7.6.3.1** Rolled sections or tubes of equivalent strength may be permitted instead of flats, for lacings.

### 7.6.4 Angle of Inclination

Lacing bars, whether in double or single systems, shall be inclined at an angle not less than  $40^\circ$  nor more than  $70^\circ$  to the axis of the built-up member.

### 7.6.5 Spacing

**7.6.5.1** The maximum spacing of lacing bars, whether connected by bolting, riveting or welding, shall also be such that the maximum slenderness ratio of the components of the main member ( $a_1/r_1$ ), between consecutive lacing connections is not greater than 50 or 0.7 times the most unfavourable slenderness ratio of the member as a whole, whichever is less, where  $a_1$  is the unsupported length of the individual member between lacing points, and  $r_1$  is the minimum radius of gyration of the individual member being laced together

**7.6.5.2** Where lacing bars are not lapped to form the connection to the components of the members, they shall be so connected that there is no appreciable interruption in the triangulation of the system.

### 7.6.6 Design of Lacings

**7.6.6.1** The lacing shall be proportioned to resist a total transverse shear,  $V_t$  at any point in the member, equal to at least 2.5 percent of the axial force in the member and shall be divided equally among all transverse-lacing systems in parallel planes.

**7.6.6.2** For members carrying calculated bending stress due to eccentricity of loading, applied end moments and/or lateral loading, the lacing shall be proportioned to resist the actual shear due to bending, in addition to that specified in **7.6.6.1**.

**7.6.6.3** The slenderness ratio,  $KL/r$ , of the lacing bars shall not exceed 145. In bolted/riveted construction, the effective length of lacing bars for the determination of the design strength shall be taken as the length between the inner end fastener of the bars for single lacing, and as 0.7 of this length for double lacings effectively connected at intersections. In welded

construction, the effective lengths shall be taken as 0.7 times the distance between the inner ends of welds connecting the single lacing bars to the members.

NOTE — The required section for lacing bars as compression/tension members shall be determined by using the appropriate design stresses,  $f_{cd}$  subject to the requirements given in **7.6.3**, to **7.6.6** and  $T_d$  in **6.1**.

### 7.6.7 Attachment to Main Members

The bolting, riveting or welding of lacing bars to the main members shall be sufficient to transmit the force calculated in the bars. Where welded lacing bars overlap the main members, the amount of lap measured along either edge of the lacing bar shall be not less than four times the thickness of the bar or the thickness of the element of the members to which it is connected, whichever is less. The welding should be sufficient to transmit the load in the bar and shall, in any case, be provided along each side of the bar for the full length of lap.

### 7.6.8 End Tie Plates

Laced compression members shall be provided with tie plates as per **7.7** at the ends of lacing systems and at intersection with other members/stays and at points where the lacing systems are interrupted.

## 7.7 Battened Columns

### 7.7.1 General

**7.7.1.1** Compression members composed of two main components battened should preferably have the individual members of the same cross-section and symmetrically disposed about their major axis. Where practicable, the compression members should have a radius of gyration about the axis perpendicular to the plane of the batten not less than the radius of gyration about the axis parallel to the plane of the batten (*see* Fig. 11).

**7.7.1.2** Battened compression members, not complying with the requirements specified in this section or those subjected to eccentricity of loading, applied moments or lateral forces in the plane of the battens (*see* Fig. 11), shall be designed according to the exact theory of elastic stability or empirically, based on verification by tests.

NOTE — If the column section is subjected to eccentricity or other moments about an axis perpendicular to battens, the battens and the column section should be specially designed for such moments and shears.

**7.7.1.3** The battens shall be placed opposite to each other at each end of the member and at points where the member is stayed in its length and as far as practicable, be spaced and proportioned uniformly throughout. The number of battens shall be such that the member is divided into not less than three bays

within its actual length from centre-to-centre of end connections.

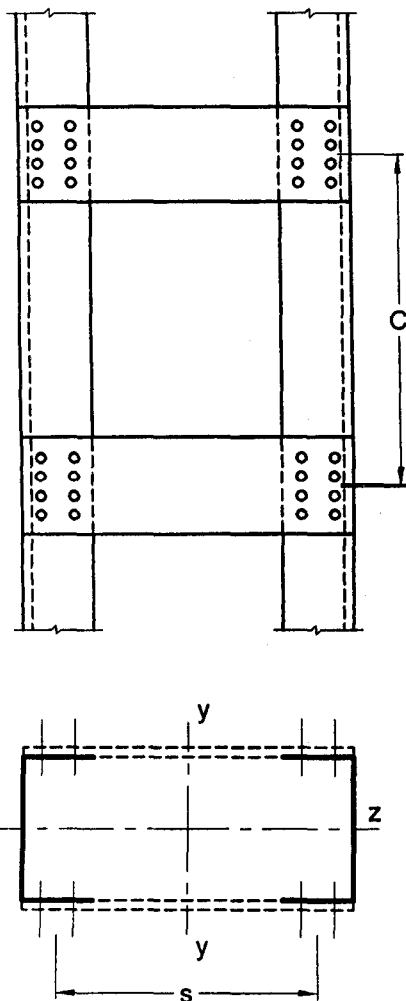


FIG. 11 BATTEN COLUMN SECTION

**7.7.1.4** The effective slenderness ratio  $(KL/r)_e$  of battened columns, shall be taken as 1.1 times the  $(KL/r)_0$ , the maximum actual slenderness ratio of the column, to account for shear deformation effects.

### 7.7.2 Design of Battens

#### 7.7.2.1 Battens

Battens shall be designed to carry the bending moments and shear forces arising from transverse shear force  $V_t$  equal to 2.5 percent of the total axial force on the whole compression member, at any point in the length of the member, divided equally between parallel planes of battens. Battened member carrying calculated bending moment due to eccentricity of axial loading, calculated end moments or lateral loads parallel to the plane of battens, shall be designed to carry actual shear in addition to the above shear. The main members shall also be checked for the same shear force and bending moments as for the battens.

Battens shall be of plates, angles, channels, or I-sections and at their ends shall be riveted, bolted or welded to the main components so as to resist simultaneously a shear  $V_b = V_t C / NS$  along the column axis and a moment  $M = V_t C / 2N$  at each connection,

where

- $V_t$  = transverse shear force as defined above;
- $C$  = distance between centre-to-centre of battens, longitudinally;
- $N$  = number of parallel planes of battens; and
- $S$  = minimum transverse distance between the centroid of the rivet/bolt group/welding connecting the batten to the main member.

#### 7.7.2.2 Tie plates

Tie plates are members provided at the ends of battened and laced members, and shall be designed by the same method as battens. In no case shall a tie plate and its fastenings be incapable of carrying the forces for which the lacing or batten has been designed.

#### 7.7.2.3 Size

When plates are used for battens, the end battens and those at points where the member is stayed in its length shall have an effective depth, longitudinally, not less than the perpendicular distance between the centroids of the main members. The intermediate battens shall have an effective depth of not less than three quarters of this distance, but in no case shall the effective depth of any batten be less than twice the width of one member, in the plane of the battens. The effective depth of a batten shall be taken as the longitudinal distance between outermost bolts, rivets or welds at the ends. The thickness of batten or the tie plates shall be not less than one-fiftieth of the distance between the innermost connecting lines of rivets, bolts or welds, perpendicular to the main member.

**7.7.2.4** The requirement of bolt size and thickness of batten specified above does not apply when angles, channels or I-sections are used for battens with their legs or flanges perpendicular to the main member. However, it should be ensured that the ends of the compression members are tied to achieve adequate rigidity.

#### 7.7.3 Spacing of Battens

In battened compression members where the individual members are not specifically checked for shear stress and bending moments, the spacing of battens, centre-to-centre of its end fastenings, shall be such that the slenderness ratio  $(KL/r)$  of any component over that distance shall be neither greater than 50 nor greater than 0.7 times the slenderness ratio of the member as a whole about its z-z (axis parallel to the battens).

#### 7.7.4 Attachment to Main Members

##### 7.7.4.1 Welded connections

Where tie or batten plates overlap the main members, the amount of lap shall be not less than four times the thickness of the plate. The length of weld connecting each edge of the batten plate to the member shall, in aggregate, be not less than half the depth of the batten plate. At least one-third of the weld shall be placed at each end of this edge. The length of weld and depth of batten plate shall be measured along the longitudinal axis of the main member.

In addition, the welding shall be returned along the other two edges of the plates transversely to the axis of the main member for a length not less than the minimum lap specified above.

#### 7.8 Compression Members Composed of Two Components Back-to-Back

**7.8.1** Compression members composed of two angles, channels, or tees back-to-back in contact or separated by a small distance, shall be connected together by riveting, bolting or welding so that the ratio of most unfavourable slenderness of each member between the intermediate connections is not greater than 40 or 0.6 times the most unfavourable ratio of slenderness of the strut as a whole, whichever is less (*see* Section 10).

**7.8.2** In no case shall the ends of the strut be connected together with less than two rivets or bolts or their equivalent in welding, and there shall be not less than two additional connections in between, spaced equidistant along the length of the strut. Where the members are separated back-to-back, the rivets or bolts through these connections shall pass through solid washers or packing in between. Where the legs of the connected angles or the connected tees are 125 mm wide or more, or where webs of channels are 150 mm wide or over, not less than two rivets or bolts shall be used in each connection, one on line of each gauge mark.

**7.8.3** Where these connections are made by welding, solid packing shall be used to effect the jointing unless the members are sufficiently close together to permit direct welding, and the members shall be connected by welding along both pairs of edges of the main components.

**7.8.4** The rivets, bolts or welds in these connections shall be sufficient to carry the shear force and moments, if any, specified for battened struts (*see* 7.7.3), and in no case shall the rivets or bolts be less than 16 mm diameter for members upto and including 10 mm thick; 20 mm diameter for members upto and including 16 mm thick; and 22 mm diameter for members over 16 mm thick.

**7.8.4.1** Compression members connected by such riveting, bolting or welding shall not be subjected to transverse loading in a plane perpendicular to the riveted, bolted or welded surfaces.

**7.8.5** Where the components are in contact back-to-back, the spacing of the rivets, bolts or intermittent welds shall not exceed the maximum spacing for compression members given in (*see* Section 10).

## SECTION 8 DESIGN OF MEMBERS SUBJECTED TO BENDING

### 8.1 General

Members subjected to predominant bending shall have adequate design strength to resist bending moment, shear force, and concentrated forces imposed upon and their combinations. Further, the members shall satisfy the deflection limitation presented in Section 5, as serviceability criteria. Member subjected to other forces in addition to bending or biaxial bending shall be designed in accordance with Section 9.

#### 8.1.1 Effective Span of Beams

The effective span of a beam shall be taken as the distance between the centre of the supports, except where the point of application of the reaction is taken as eccentric at the support, when it shall be permissible to take the effective span as the length between the assumed lines of the reactions.

### 8.2 Design Strength in Bending (Flexure)

The design bending strength of beam, adequately supported against lateral torsional buckling (laterally supported beam) is governed by the yield stress (*see* 8.2.1). When a beam is not adequately supported against lateral buckling (laterally un-supported beams) the design bending strength may be governed by lateral torsional buckling strength (*see* 8.2.2).

The factored design moment,  $M$  at any section, in a beam due to external actions, shall satisfy

$$M \leq M_d$$

where

$M_d$  = design bending strength of the section, calculated as given in 8.2.1.2.

#### 8.2.1 Laterally Supported Beam

A beam may be assumed to be adequately supported at the supports, provided the compression flange has full lateral restraint and nominal torsional restraint at supports supplied by web cleats, partial depth end plates, fin plates or continuity with the adjacent span. Full lateral restraint to compression flange may be

assumed to exist if the frictional or other positive restraint of a floor connection to the compression flange of the member is capable of resisting a lateral force not less than 2.5 percent of the maximum force in the compression flange of the member. This may be considered to be uniformly distributed along the flange, provided gravity loads constitute the dominant loading on the member and the floor construction is capable of resisting this lateral force.

The design bending strength of a section which is not susceptible to web buckling under shear before yielding (where  $d/t_w \leq 67\epsilon$ ) shall be determined according to 8.2.1.2.

#### 8.2.1.1 Section with webs susceptible to shear buckling before yielding

When the flanges are plastic, compact or semi-compact but the web is susceptible to shear buckling before yielding ( $d/t_w \leq 67\epsilon$ ), the design bending strength shall be calculated using one of the following methods:

- The bending moment and axial force acting on the section may be assumed to be resisted by flanges only and the web is designed only to resist shear (see 8.4).
- The bending moment and axial force acting on the section may be assumed to be resisted by the whole section. In such a case, the web shall be designed for combined shear and normal stresses using simple elastic theory in case of semi-compact webs and simple plastic theory in the case of compact and plastic webs.

8.2.1.2 When the factored design shear force does not exceed  $0.6 V_d$ , where  $V_d$  is the design shear strength of the cross-section (see 8.4), the design bending strength,  $M_d$  shall be taken as:

$$M_d = \beta_b Z_p f_y / \gamma_{m0}$$

To avoid irreversible deformation under serviceability loads,  $M_d$  shall be less than  $1.2 Z_e f_y / \gamma_{m0}$  in case of simply supported and  $1.5 Z_e f_y / \gamma_{m0}$  in cantilever beams;

where

$\beta_b = 1.0$  for plastic and compact sections;

$\beta_b = Z_e / Z_p$  for semi-compact sections;

$Z_p, Z_e =$  plastic and elastic section moduli of the cross-section, respectively;

$f_y =$  yield stress of the material; and

$\gamma_{m0} =$  partial safety factor (see 5.4.1).

8.2.1.3 When the design shear force (factored),  $V$  exceeds  $0.6V_d$ , where  $V_d$  is the design shear strength of the cross-section (see 8.4) the design bending strength,  $M_d$  shall be taken

$$M_d = M_{dv}$$

where

$M_{dv} =$  design bending strength under high shear as defined in 9.2.

#### 8.2.1.4 Holes in the tension zone

- The effect of holes in the tension flange, on the design bending strength need not be considered if

$$(A_{nf} / A_{gr}) \geq (f_y / f_u) (\gamma_{m1} / \gamma_{m0}) / 0.9$$

where

$A_{nf} / A_{gr} =$  ratio of net to gross area of the flange in tension,

$f_y / f_u =$  ratio of yield and ultimate stress of the material, and

$\gamma_{m1} / \gamma_{m0} =$  ratio of partial safety factors against ultimate to yield stress (see 5.4.1).

When the  $A_{nf} / A_{gr}$  does not satisfy the above requirement, the reduced effective flange area,  $A_{ef}$  satisfying the above equation may be taken as the effective flange area in tension, instead of  $A_{gr}$ .

- The effect of holes in the tension region of the web on the design flexural strength need not be considered, if the limit given in (a) above is satisfied for the complete tension zone of the cross-section, comprising the tension flange and tension region of the web.
- Fastener holes in the compression zone of the cross-section need not be considered in design bending strength calculation, except for oversize and slotted holes or holes without any fastener.

#### 8.2.1.5 Shear lag effects

The shear lag effects in flanges may be disregarded provided:

- For outstand elements (supported along one edge),  $b_o \leq L_o / 20$ ; and
- For internal elements (supported along two edges),  $b_i \leq L_o / 10$ .

where

$L_o =$  length between points of zero moment (inflection) in the span,

$b_o =$  width of the flange with outstand, and

$b_i =$  width of the flange as an internal element.

Where these limits are exceeded, the effective width of flange for design strength may be calculated using



specialist literature, or conservatively taken as the value satisfying the limit given above.

### 8.2.2 Laterally Unsupported Beams

Resistance to lateral torsional buckling need not be checked separately (member may be treated as laterally supported, *see* 8.2.1) in the following cases:

- Bending is about the minor axis of the section,
- Section is hollow (rectangular/ tubular) or solid bars, and
- In case of major axis bending,  $\lambda_{LT}$  (as defined herein) is less than 0.4.

The design bending strength of laterally unsupported beam as governed by lateral torsional buckling is given by:

$$M_d = \beta_b Z_p f_{bd}$$

where

$\beta_b = 1.0$  for plastic and compact sections.

$= Z_e/Z_p$  for semi-compact sections.

$Z_p, Z_e =$  plastic section modulus and elastic section modulus with respect to extreme compression fibre.

$f_{bd} =$  design bending compressive stress, obtained as given below [*see* Tables 13(a) and 13(b)]

$$f_{bd} = \chi_{LT} f_y / \gamma_{m0}$$

$\chi_{LT} =$  bending stress reduction factor to account for lateral torsional buckling, given by:

$$\chi_{LT} = \frac{1}{\left\{ \phi_{LT} + \left[ \phi_{LT}^2 - \lambda_{LT}^2 \right]^{0.5} \right\}} \leq 1.0$$

$$\phi_{LT} = 0.5 \left[ 1 + \alpha_{LT} (\lambda_{LT} - 0.2) + \lambda_{LT}^2 \right]$$

$\alpha_{LT}$ , the imperfection parameter is given by:

$\alpha_{LT} = 0.21$  for rolled steel section

$\alpha_{LT} = 0.49$  for welded steel section

The non-dimensional slenderness ratio,  $\lambda_{LT}$ , is given by

$$\begin{aligned} \lambda_{LT} &= \sqrt{\beta_b Z_p f_y / M_{cr}} \leq \sqrt{1.2 Z_e f_y / M_{cr}} \\ &= \sqrt{f_y / f_{cr, b}} \end{aligned}$$

where

$M_{cr} =$  elastic critical moment calculated in accordance with 8.2.2.1, and

$f_{cr, b} =$  extreme fibre bending compressive stress

corresponding to elastic lateral buckling moment (*see* 8.2.2.1 and Table 14).

#### 8.2.2.1 Elastic lateral torsional buckling moment

In case of simply supported, prismatic members with symmetric cross-section, the elastic lateral buckling moment,  $M_{cr}$ , can be determined from:

$$M_{cr} = \sqrt{\left\{ \left( \frac{\pi^2 EI_y}{(L_{LT})^2} \right) \left[ GI_t + \frac{\pi^2 EI_w}{(L_{LT})^2} \right] \right\}} = \beta_b Z_p f_{cr, b}$$

$f_{cr, b}$  of non-slender rolled steel sections in the above equation may be approximately calculated from the values given in Table 14, which has been prepared using the following equation:

$$f_{cr, b} = \frac{1.1 \pi^2 E}{(L_{LT}/r_y)^2} \left[ 1 + \frac{1}{20} \left( \frac{L_{LT}/r_y}{h_f/t_f} \right)^2 \right]^{0.5}$$

The following simplified equation may be used in the case of prismatic members made of standard rolled I-sections and welded doubly symmetric I-sections, for calculating the elastic lateral buckling moment,  $M_{cr}$  (*see* Table 14):

$$M_{cr} = \frac{\pi^2 EI_y h_f}{2 L_{LT}^2} \left[ 1 + \frac{1}{20} \left( \frac{L_{LT}/r_y}{h_f/t_f} \right)^2 \right]^{0.5}$$

where

$I_t =$  torsional constant =  $\sum b_i t_i^3 / 3$  for open section;

$I_w =$  warping constant;

$I_y, r_y =$  moment of inertia and radius of gyration, respectively about the weaker axis;

$L_{LT} =$  effective length for lateral torsional buckling (*see* 8.3);

$h_f =$  centre-to-centre distance between flanges; and

$t_f =$  thickness of the flange.

$M_{cr}$  for different beam sections, considering loading, support condition, and non-symmetric section, shall be more accurately calculated using the method given in Annex E.

### 8.3 Effective Length for Lateral Torsional Buckling

**8.3.1** For simply supported beams and girders of span length,  $L$ , where no lateral restraint to the compression flanges is provided, but where each end of the beam is restrained against torsion, the effective length  $L_{LT}$  of the lateral buckling to be used in 8.2.2.1 shall be taken as in Table 15.

Table 13(a) Design Bending Compressive Stress Corresponding to Lateral Buckling,  $f_{bd}$ ,  $\alpha_{LT} = 0.21$   
(Clause 8.2.2)

$f_{crb}$	$f_y$																		
	200	210	220	230	240	250	260	280	300	320	340	360	380	400	420	450	480	510	540
10 000	181.8	190.9	200	209.1	218.2	227.3	236.4	254.5	272.7	290.9	309.1	327.3	345.5	363.6	381.8	409.1	436.4	463.6	490.9
8 000	181.8	190.9	200	209.1	218.2	227.3	236.4	254.5	272.7	290.9	309.1	327.3	345.5	363.6	381.8	409.1	436.4	463.6	490.9
6 000	181.8	190.9	200	209.1	218.2	227.3	236.4	254.5	272.7	290.9	309.1	327.3	345.5	363.6	381.8	409.1	436.4	463.6	490.9
4 000	181.8	190.9	200	209.1	218.2	227.3	236.4	254.5	272.7	290.9	309.1	327.3	345.5	363.6	381.8	409.1	436.4	463.6	490.9
2 000	181.8	190.9	200	209.1	218.2	227.3	236.4	254.5	272.7	290.9	309.1	327.3	345.5	363.6	381.8	409.1	436.4	463.6	490.9
1 000	169.1	179.5	186	196.5	202.9	209.1	219.8	229.1	245.5	261.8	275.1	291.3	300.5	323.6	332.2	355.9	370.9	384.8	412.4
900	169.1	179.5	186	194.5	200.7	204.5	215.1	231.6	242.7	258.9	272	291.3	300.5	316.4	328.4	339.5	366.5	380.2	392.7
800	167.3	177.5	184	190.3	196.4	206.8	212.7	224	240	258.9	268.9	284.7	293.6	301.8	324.5	335.5	349.1	370.9	387.8
700	163.6	171.8	182	188.2	192	202.3	208	226.5	237.3	250.2	259.6	278.2	286.7	294.5	305.5	327.3	340.4	352.4	363.3
600	161.8	168	176	181.9	194.2	197.7	203.3	218.9	226.4	244.4	253.5	261.8	276.4	287.3	294	306.8	322.9	333.8	343.6
500	161.8	166.1	172	179.8	185.5	188.6	200.9	208.7	218.2	232.7	244.2	248.7	259.1	269.1	274.9	286.4	296.7	301.4	314.2
450	158.2	164.2	168	173.5	183.3	186.4	191.5	206.2	215.5	224	231.8	242.2	248.7	258.2	263.5	274.1	279.3	292.1	294.5
400	150.9	162.3	166	169.4	174.5	184.1	186.7	196	204.5	215.3	222.5	229.1	238.4	243.6	248.2	257.7	261.8	264.3	274.9
350	147.3	152.7	162	165.2	170.2	172.7	179.6	188.4	193.6	200.7	210.2	212.7	221.1	225.5	229.1	233.2	240	241.1	245.5
300	143.6	147	152	154.7	161.5	163.6	167.8	175.6	182.7	186.2	194.7	196.4	196.9	203.6	206.2	212.7	213.8	217.9	220.9
250	134.5	137.5	142	144.3	148.4	152.3	153.6	160.4	163.6	165.8	170	173.5	179.6	178.2	179.5	184.1	183.3	185.5	191.5
200	121.8	124.1	126	129.6	130.9	134.1	134.7	137.5	141.8	142.5	145.3	147.3	148.5	149.1	152.7	151.4	152.7	153	157.1
150	101.8	103.1	104	104.5	106.9	106.8	108.7	109.5	111.8	113.5	114.4	114.5	117.5	116.4	118.4	118.6	117.8	120.5	122.7
100	74.5	76.4	76	77.4	76.4	77.3	78	78.9	79.1	78.5	80.4	81.8	79.5	80	80.2	81.8	82.9	83.5	83.5
90	67.3	68.7	70	69	69.8	70.5	70.9	71.3	70.9	72.7	74.2	72	72.5	72.7	72.5	73.6	74.2	74.2	73.6
80	61.8	63	62	62.7	63.3	63.6	63.8	63.6	65.5	64	64.9	65.5	65.6	65.5	64.9	65.5	65.5	64.9	68.7
70	54.5	55.4	56	56.5	56.7	56.8	56.7	56	57.3	58.2	58.7	58.9	58.7	58.2	57.3	57.3	56.7	60.3	58.9
60	47.3	47.7	48	48.1	48	50	49.6	48.4	49.1	49.5	49.5	49.1	48.4	50.9	49.6	49.1	52.4	51	49.1
50	40	40.1	40	41.8	41.5	40.9	40.2	40.7	40.9	40.7	43.3	42.5	41.5	43.6	42	40.9	43.6	41.7	44.2
40	32.7	32.5	32	33.5	32.7	34.1	33.1	33.1	32.7	34.9	34	32.7	34.5	32.7	34.4	32.7	34.9	32.5	34.4
30	25.5	24.8	26	25.1	26.2	25	26	25.5	24.5	26.2	24.7	26.2	24.2	25.5	26.7	24.5	26.2	27.8	24.5
20	16.4	17.2	18	16.7	17.5	18.2	16.5	17.8	16.4	17.5	18.5	16.4	17.3	18.2	19.1	16.4	17.5	18.5	19.6
10	9.1	9.5	8	8.4	8.7	9.1	9.5	7.6	8.2	8.7	9.3	9.8	10.4	7.3	7.6	8.2	8.7	9.3	9.8

**Table 13(b) Design Bending Compressive Stress Corresponding to Lateral Buckling,  $f_{bd}$ ,  $\alpha_{LT} = 0.49$**   
(Clause 8.2.2)

$f_{cr,b}$	$f_y$																		
	200	210	220	230	240	250	260	280	300	320	340	360	380	400	420	450	480	510	540
10 000	181.8	190.9	200.0	209.1	218.2	227.3	236.4	254.5	272.7	290.9	309.1	327.3	345.5	363.6	381.8	409.1	436.4	463.6	490.9
8 000	181.8	190.9	200.0	209.1	218.2	227.3	236.4	254.5	272.7	290.9	309.1	327.3	345.5	363.6	381.8	409.1	436.4	463.6	490.9
6 000	181.8	190.9	200.0	209.1	218.2	227.3	236.4	254.5	272.7	290.9	309.1	327.3	345.5	363.6	381.8	409.1	436.4	463.6	490.9
4 000	181.8	190.9	200.0	209.1	218.2	227.3	236.4	254.5	272.7	290.9	309.1	327.3	345.5	363.6	381.8	409.1	436.4	463.6	490.9
2 000	181.8	190.9	200.0	209.1	218.2	227.3	236.4	254.5	272.7	290.9	309.1	327.3	345.5	363.6	381.8	409.1	436.4	463.6	490.9
1 000	160.0	164.2	170.0	179.8	185.5	190.9	196.2	211.3	220.9	235.6	247.3	255.3	266.0	280	290.2	302.7	318.5	329.2	343.6
900	154.5	164.2	170.0	173.5	183.3	188.6	193.8	203.6	218.2	226.9	238.0	252.0	262.5	269.1	282.5	290.5	305.5	319.9	333.8
800	152.7	158.5	168.0	171.5	176.7	181.8	191.5	201.1	210.0	224.0	234.9	242.2	252.2	258.2	271.1	282.3	296.7	306	319.1
700	150.9	154.6	160.0	169.4	172.4	177.3	182.0	196	207.3	215.3	222.5	232.4	238.4	247.3	259.6	270	279.3	292.1	304.4
600	145.5	150.8	154.0	161.0	168.0	172.7	177.3	188.4	193.6	203.6	213.3	222.5	228	236.4	244.4	253.6	261.8	273.5	274.9
500	140.0	145.1	150.0	154.7	159.3	161.4	167.8	175.6	185.5	192	200.9	206.2	214.2	218.2	225.3	229.1	240	245.7	250.4
450	134.5	141.3	144.0	148.5	152.7	156.8	160.7	168	177.3	186.2	191.6	196.4	203.8	210.9	213.8	220.9	231.3	236.5	235.6
400	129.1	135.5	138.0	142.2	148.4	150	153.6	162.9	169.1	174.5	182.4	183.3	193.5	196.4	202.4	208.6	209.5	217.9	220.9
350	123.6	129.8	132.0	135.9	139.6	143.2	148.9	152.7	158.2	162.9	170	173.5	176.2	181.8	183.3	192.3	196.4	199.4	206.2
300	118.2	122.2	126.0	129.6	130.9	134.1	137.1	142.5	147.3	154.2	157.6	157.1	162.4	167.3	168	175.9	178.9	180.8	181.6
250	109.1	112.6	116.0	117.1	120.0	122.7	125.3	129.8	130.9	136.7	139.1	140.7	145.1	149.1	148.9	151.4	152.7	157.6	157.1
200	98.2	101.2	102.0	104.5	104.7	109.1	108.7	112	117.3	119.3	120.5	121.1	124.4	127.3	126	130.9	130.9	129.8	132.5
150	83.6	84.0	86.0	87.8	89.5	88.6	89.8	91.6	95.5	96.0	95.8	98.2	100.2	101.8	103.1	102.3	104.7	106.6	103.1
100	63.6	63.0	64.0	64.8	65.5	65.9	66.2	68.7	68.2	69.8	71.1	68.7	69.1	72.7	72.5	73.6	74.2	74.2	73.6
90	58.2	57.3	60.0	58.5	61.1	61.4	61.5	61.1	62.7	64.0	64.9	65.5	65.6	65.5	64.9	65.5	65.5	64.9	68.7
80	52.7	53.5	54.0	54.4	54.5	54.5	54.4	56	57.3	58.2	58.7	58.9	58.7	58.2	61.1	61.4	61.1	60.3	58.9
70	47.3	47.7	48.0	48.1	48.0	50.0	49.6	50.9	49.1	49.5	52.5	52.4	51.8	50.9	53.5	53.2	52.4	55.6	54.0
60	41.8	42.0	42.0	41.8	43.6	43.2	42.5	43.3	43.6	43.6	43.3	45.8	44.9	47.3	45.8	45.0	48.0	46.4	49.1
50	36.4	36.3	36.0	35.5	37.1	36.4	37.8	38.2	38.2	37.8	37.1	39.3	38.0	40.0	38.2	40.9	39.3	37.1	39.3
40	29.1	30.5	30.0	29.3	30.5	29.5	30.7	30.5	30.0	32.0	30.9	32.7	31.1	32.7	30.5	32.7	30.5	32.5	34.4
30	23.6	22.9	22.0	23.0	24.0	22.7	23.6	22.9	24.5	23.3	24.7	22.9	24.2	25.5	22.9	24.5	26.2	23.2	24.5
20	16.4	15.3	16.0	16.7	15.3	15.9	16.5	15.3	16.4	17.5	15.5	16.4	17.3	18.2	15.3	16.4	17.5	18.5	14.7
10	9.1	7.6	8.0	8.4	8.7	9.1	9.5	7.6	8.2	8.7	9.3	9.8	6.9	7.3	7.6	8.2	8.7	9.3	9.8

**Table 14 Critical Stress,  $f_{cr, b}$**   
(Clause 8.2.2.1)

KL/r	h/t <sub>r</sub>															
	8	10	12	14	16	18	20	25	30	35	40	50	60	80	100	
10	22 551.2	22 255.1	22 092.6	21 994.1	21 929.8	21 885.7	21 854.0	21 805.4	21 779.0	21 763.1	21 752.7	21 740.5	21 733.8	21 727.2	21 724.2	
20	6 220.5	5 947.9	5 794.5	5 700.0	5 637.8	5 594.7	5 563.8	5 515.8	5 489.7	5 473.8	5 463.5	5 451.4	5 444.8	5 438.2	5 435.1	
30	3 149.3	2 905.9	2 764.6	2 676.0	2 616.7	2 575.3	2 545.3	2 498.5	2 472.8	2 457.1	2 447.0	2 434.9	2 428.3	2 421.7	2 418.6	
40	2 036.1	1 821.2	1 693.0	1 610.8	1 555.1	1 515.8	1 487.0	1 441.7	1 416.5	1 401.1	1 391.0	1 379.0	1 372.5	1 365.9	1 362.8	
50	1 492.9	1 303.2	1 187.3	1 111.8	1 059.9	1 022.7	995.3	951.7	927.1	912.0	902.0	890.2	883.7	877.1	874.2	
60	1 178.0	1 009.5	905.0	835.6	787.4	752.4	726.4	684.6	660.9	646.1	636.4	624.7	618.2	611.7	608.7	
70	973.9	823.2	728.5	664.8	620.1	587.4	562.9	522.9	500.0	485.5	476.0	464.4	458.0	451.7	448.7	
80	831.3	695.4	609.2	550.7	509.1	478.4	455.3	417.2	395.1	381.2	371.8	360.5	354.1	347.7	344.7	
90	725.9	602.6	523.6	469.5	430.9	402.2	380.4	344.2	322.9	309.3	300.2	289.1	282.8	276.5	273.5	
100	644.7	532.0	459.3	409.3	373.2	346.4	325.8	291.4	270.9	257.7	248.8	237.9	231.8	225.5	222.5	
110	580.4	476.6	409.3	362.9	329.2	303.9	284.5	251.8	232.1	219.3	210.8	200.1	194.0	187.8	184.8	
120	527.9	431.9	369.5	326.0	294.5	270.7	252.3	221.2	202.4	190.1	181.6	171.2	165.2	159.1	156.2	
130	484.3	395.0	336.8	296.1	266.5	244.1	226.7	197.1	179.0	167.1	158.8	148.6	142.8	136.7	133.9	
140	447.6	364.2	309.5	271.5	243.4	222.3	205.8	177.5	160.2	148.7	140.7	130.8	125.0	119.0	116.2	
150	416.0	337.8	286.6	250.6	224.2	204.2	188.4	161.5	144.8	133.7	126.0	116.3	110.6	104.7	101.9	
160	388.7	315.2	266.8	232.8	207.8	188.8	173.9	148.2	132.0	121.3	113.9	104.3	98.8	93.0	90.1	
170	364.9	295.4	249.6	217.5	193.7	175.6	161.4	136.7	121.3	111.0	103.6	94.4	89.0	83.2	80.4	
180	343.9	278.0	234.6	204.1	181.5	164.2	150.6	127.1	112.2	102.2	95.2	86.0	80.7	75.0	72.3	
190	325.2	262.6	221.3	192.3	170.7	154.2	141.2	118.6	104.3	94.6	87.8	79.0	73.7	68.1	65.3	
200	308.3	248.8	209.6	181.7	161.2	145.4	133.0	111.3	97.5	88.1	81.4	72.8	67.8	62.2	59.5	
210	293.3	236.5	198.9	172.4	152.7	137.6	125.7	104.8	91.5	82.4	75.9	67.5	62.6	57.1	54.5	
220	279.5	225.3	189.3	163.9	145.1	130.6	119.1	99.0	86.2	77.4	71.2	62.9	58.1	52.7	50.1	
230	267.1	215.2	180.7	156.3	138.2	124.3	113.3	93.9	81.5	72.9	66.9	58.9	54.1	48.8	46.2	
240	255.8	205.8	172.8	149.4	132.0	118.6	108.0	89.3	77.2	69.0	63.1	55.3	50.6	45.4	42.8	
250	245.3	197.3	165.6	143.0	126.3	113.4	103.2	85.1	73.5	65.5	59.7	52.1	47.5	42.4	39.8	
260	235.7	189.5	159.0	137.3	121.1	108.7	98.8	81.3	70.1	62.3	56.7	49.3	44.8	39.7	37.2	
270	226.8	182.3	152.8	131.9	116.3	104.3	94.7	77.9	67.0	59.4	53.9	46.8	42.2	37.3	34.8	
280	218.6	175.7	147.2	126.9	111.9	100.2	91.1	74.7	64.1	56.8	51.5	44.4	40.0	35.2	32.7	
290	210.9	169.4	141.9	122.3	107.8	96.6	87.7	71.8	61.5	54.3	49.2	42.2	38.1	33.2	30.8	
300	203.8	163.7	137.1	118.1	104.1	93.2	84.5	69.1	59.1	52.1	47.1	40.4	36.2	31.5	29.0	

In simply supported beams with intermediate lateral restraints against lateral torsional buckling, the effective length for lateral torsional buckling to be used in 8.2.2.1,  $L_{LT}$  shall be taken as the length of the relevant segment in between the lateral restraints. The effective length shall be equal to 1.2 times the length of the relevant segment in between the lateral restraints.

Restraint against torsional rotation at supports in these beams may be provided by:

- web or flange cleats, or
- bearing stiffeners acting in conjunction with the bearing of the beam, or
- lateral end frames or external supports providing lateral restraint to the compression flanges at the ends, or
- their being built into walls.

**8.3.2** For beams, which are provided with members giving effective lateral restraint to the compression flange at intervals along the span, in addition to the end torsional restraint required in 8.3.1, the effective length for lateral torsional buckling shall be taken as the distance, centre-to-centre of the restraint members in the relevant segment under normal loading condition and 1.2 times this distance, where the load is not acting on the beam at the shear and is acting towards the shear centre so as to have destabilizing effect during lateral torsional buckling deformation.

**8.3.3** For cantilever beams of projecting length  $L$ , the effective length  $L_{LT}$  to be used in 8.2.2.1 shall be taken as in Table 16 for different support conditions.

**8.3.4** Where a member is provided intermediate lateral supports to improve the lateral buckling strength, these restraints should have sufficient strength and stiffness to prevent lateral movement of the compression flange

at that point, relative to the end supports. The intermediate lateral restraints should be either connected to an appropriate bracing system capable of transferring the restraint force to the effective lateral support at the ends of the member, or should be connected to an independent robust part of the structure capable of transferring the restraint force. Two or more parallel member requiring such lateral restraint shall not be simply connected together assuming mutual dependence for the lateral restraint.

The intermediate lateral restraints should be connected to the member as close to the compression flange as practicable. Such restraints should be closer to the shear centre of the compression flange than to the shear centre of the section. However, if torsional restraint preventing relative rotation between the two flanges is provided, the intermediate lateral restraint may be connected at any appropriate level.

For beams which are provided with members giving effective lateral restraint at intervals along the span, the effective lateral restraint shall be capable of resisting a force of 2.5 percent of the maximum force in the compression flange taken as divided equally between the points at which the restraint members are provided. Further, each restraint point should be capable of resisting 1 percent of the maximum force in the compression flange.

**8.3.4.1** In a series of such beams, with solid webs, which are connected together by the same system of restraint members, the sum of the restraining forces required shall be taken as 2.5 percent of the maximum flange force in one beam only.

**8.3.4.2** In the case of a series of latticed beams, girders or roof trusses which are connected together by the same system of restraint members, the sum of the restraining

**Table 15 Effective Length for Simply Supported Beams,  $L_{LT}$**

(Clause 8.3.1)

Sl No.	Conditions of Restraint at Supports		Loading Condition	
	Torsional Restraint	Warping Restraint	Normal	Destabilizing
(1)	(2)	(3)	(4)	(5)
i)	Fully restrained	Both flanges fully restrained	$0.70 L$	$0.85 L$
ii)	Fully restrained	Compression flange fully restrained	$0.75 L$	$0.90 L$
iii)	Fully restrained	Both flanges fully restrained	$0.80 L$	$0.95 L$
iv)	Fully restrained	Compression flange partially restrained	$0.85 L$	$1.00 L$
v)	Fully restrained	Warping not restrained in both flanges	$1.00 L$	$1.20 L$
vi)	Partially restrained by bottom flange support connection	Warping not restrained in both flanges	$1.0 L + 2 D$	$1.2 L + 2 D$
vii)	Partially restrained by bottom flange bearing support	Warping not restrained in both flanges	$1.2 L + 2 D$	$1.4 L + 2 D$

NOTES

- Torsional restraint prevents rotation about the longitudinal axis.
- Warping restraint prevents rotation of the flange in its plane.
- $D$  is the overall depth of the beam.

forces required shall be taken as 2.5 percent of the maximum force in the compression flange plus 1.25 percent of this force for every member of the series other than the first, up to a maximum total of 7.5 percent.

**8.3.5** Purlins adequately restrained by sheeting need not be normally checked for the restraining forces required by rafters, roof trusses or portal frames that carry predominately roof loads provided there is bracing of adequate stiffness in the plane of rafters or roof sheeting which is capable of acting as a stressed skin diaphragm.

**8.3.6** In case of beams with double curvature bending, adequate direct lateral support to the compression flange in the hogging moment region may be provided as given above for simply supported beam. The effect of support to the tension (top) flange in the hogging moment region on lateral restraint to the compression flange may be considered as per specialist literature.

#### 8.4 Shear

The factored design shear force,  $V$ , in a beam due to external actions shall satisfy

$$V \leq V_d$$

where

$$\begin{aligned} V_d &= \text{design strength} \\ &= V_n / \gamma_{m0} \end{aligned}$$

where

$$\gamma_{m0} = \text{partial safety factor against shear failure (see 5.4.1).}$$

The nominal shear strength of a cross-section,  $V_n$ , may be governed by plastic shear resistance (see 8.4.1) or strength of the web as governed by shear buckling (see 8.4.2).

**8.4.1** The nominal plastic shear resistance under pure shear is given by:

$$V_n = V_p$$

where

$$V_p = \frac{A_v f_{yw}}{\sqrt{3}}$$

$A_v$  = shear area, and

$f_{yw}$  = yield strength of the web.

**8.4.1.1** The shear area may be calculated as given below:

I and channel sections:

*Major Axis Bending:*

Hot-Rolled —  $h t_w$

Welded —  $d t_w$

*Minor Axis Bending:*

Hot-Rolled or Welded —  $2b t_f$

*Rectangular hollow sections of uniform thickness:*

Loaded parallel to depth ( $h$ ) —  $A h / (b + h)$

Loaded parallel to width ( $b$ ) —  $A b / (b + h)$

*Circular hollow tubes of uniform thickness* —  $2 A / \pi$

*Plates and solid bars* —  $A$

where

$A$  = cross-section area,

$b$  = overall breadth of tubular section, breadth of I-section flanges,

$d$  = clear depth of the web between flanges,

$h$  = overall depth of the section,

$t_f$  = thickness of the flange, and

$t_w$  = thickness of the web.

NOTE — Fastener holes need not be accounted for in plastic design shear strength calculation provided that:

$$A_{vn} \geq (f_y / f_u) (\gamma_{m1} / \gamma_{m0}) A_v / 0.9$$

If  $A_{vn}$  does not satisfy the above condition, the effective shear area may be taken as that satisfying the above limit. Block shear failure criteria may be verified at the end connections. Section 9 may be referred to for design strength under combined high shear and bending.

#### 8.4.2 Resistance to Shear Buckling

**8.4.2.1** Resistance to shear buckling shall be verified as specified, when

$$d / t_w > 67 \epsilon \text{ for a web without stiffeners, and}$$

$$> 67 \epsilon \sqrt{\frac{K_v}{5.35}} \text{ for a web with stiffeners}$$

where

$K_v$  = shear buckling coefficient (see 8.4.2.2), and

$$\epsilon = \sqrt{250 / f_y}$$

#### 8.4.2.2 Shear buckling design methods

The nominal shear strength,  $V_n$ , of webs with or without intermediate stiffeners as governed by buckling may be evaluated using one of the following methods:

- Simple post-critical method* — The simple post critical method, based on the shear buckling strength can be used for webs of I-section girders, with or without intermediate transverse stiffener, provided that the web has transverse stiffeners at the supports. The nominal shear strength is given by:

$$V_n = V_{cr}$$

where

$$V_{cr} = \text{shear force corresponding to web buckling}$$

$$= A_v \tau_b$$

where

$\tau_b$  = shear stress corresponding to web buckling, determined as follows:

1) when  $\lambda_w \leq 0.8$

$$\tau_b = f_{yw} / \sqrt{3}$$

2) when  $0.8 < \lambda_w < 1.2$

$$\tau_b = [1 - 0.8(\lambda_w - 0.8)](f_{yw} / \sqrt{3})$$

3) when  $\lambda_w \geq 1.2$   $\tau_b = f_{yw} / (\sqrt{3}\lambda_w^2)$

where

$\lambda_w$  = non-dimensional web slenderness ratio for shear buckling stress, given by:

$$\lambda_w = \sqrt{f_{yw} / (\sqrt{3}\tau_{cr,e})}$$

$\tau_{cr,e}$  = the elastic critical shear stress of the

$$\text{web} = \frac{K_v \pi^2 E}{12(1 - \mu^2) [d/t_w]^2}$$

where

$\mu$  = Poisson's ratio, and

$K_v$  = 5.35 when transverse stiffeners are provided only at supports

$$= 4.0 + 5.35 / (c/d)^2 \text{ for } c/d < 1.0$$

$$= 5.35 + 4.0 / (c/d)^2 \text{ for } c/d \geq 1.0$$

where  $c$ ,  $d$  are the spacing of transverse stiffeners and depth of the web, respectively.

- b) *Tension field method* — The tension field method, based on the post-shear buckling strength, may be used for webs with intermediate transverse stiffeners, in addition to the transverse stiffeners at supports, provided the panels adjacent to the panel under tension field action, or the end posts provide anchorage for the tension fields and if  $c/d \geq 1.0$ , where  $c$ ,  $d$  are the spacing of transverse stiffeners and depth of the web, respectively.

In the tension field method, the nominal shear resistance,  $V_n$ , is given by:

$$V_n = V_{tf}$$

where

$$V_{tf} = [A_v \tau_b + 0.9 w_{tf} t_w f_v \sin \phi] \leq V_p$$

where

$\tau_b$  = buckling strength, as obtained from 8.4.2.2(a)

$f_v$  = yield strength of the tension field obtained from

$$= [f_{yw}^2 - 3\tau_b^2 + \psi^2]^{0.5} - \psi$$

$\psi$  =  $1.5 \tau_b \sin 2\phi$

$\phi$  = inclination of the tension field

$$= \tan^{-1} \left( \frac{d}{c} \right)$$

$w_{tf}$  = the width of the tension field, given by:

$$= d \cos \phi + (c - s_c - s_t) \sin \phi$$

$f_{yw}$  = yield stress of the web

$d$  = depth of the web

$c$  = spacing of stiffeners in the web

$\tau_b$  = shear stress corresponding to buckling of web 8.4.2.2(a)

$s_c, s_t$  = anchorage lengths of tension field along the compression and tension flange respectively, obtained from:

$$s = \frac{2}{\sin \phi} \left[ \frac{M_{fr}}{f_{yw} t_w} \right]^{0.5} \leq c$$

where

$M_{fr}$  = reduced plastic moment capacity of the respective flange plate (disregarding any edge stiffener) after accounting for the axial force,  $N_f$  in the flange, due to overall bending and any external axial force in the cross-section, and is calculated as:

$$M_{fr} = 0.25 b_f t_f^2 f_{yf} \left[ 1 - \left\{ N_f / (b_f t_f f_{yf} / \gamma_{m0}) \right\}^2 \right]$$

where

$b_f, t_f$  = width and thickness of the relevant flange respectively

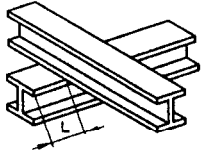
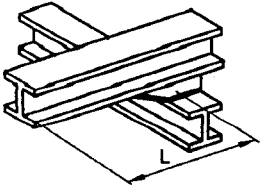
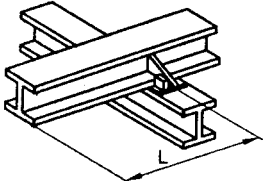
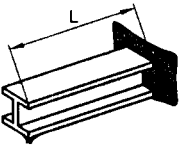
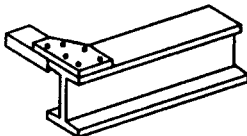
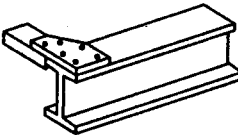
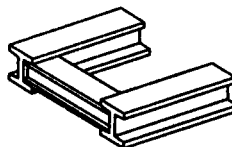
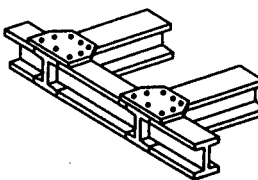
$f_{yf}$  = yield stress of the flange

## 8.5 Stiffened Web Panels

### 8.5.1 End Panels Design (see Fig. 12)

The design of end panels in girders in which the interior panel (panel A) is designed using tension field action shall be carried in accordance with the provisions given herein. In this case the end panel should be designed

**Table 16 Effective Length,  $L_{LT}$  for Cantilever of Length,  $L$**   
(Clause 8.3.3)

Restraint Condition		Loading Condition	
At Support	At Top	Normal	Destabilizing
(1)	(2)	(3)	(4)
<p>a) Continuous, with lateral restraint to top flange</p> 	<p>i) Free ii) Lateral restraint to top flange iii) Torsional restraint iv) Lateral and torsional restraint</p>	<p><math>3.0L</math> <math>2.7L</math> <math>2.4L</math> <math>2.1L</math></p>	<p><math>7.5L</math> <math>7.5L</math> <math>4.5L</math> <math>3.6L</math></p>
<p>b) Continuous, with partial torsional restraint</p> 	<p>i) Free ii) Lateral restraint to top flange iii) Torsional restraint iv) Lateral and torsional restraint</p>	<p><math>2.0L</math> <math>1.8L</math> <math>1.6L</math> <math>1.4L</math></p>	<p><math>5.0L</math> <math>5.0L</math> <math>3.0L</math> <math>2.4L</math></p>
<p>c) Continuous, with lateral and torsional restraint</p> 	<p>i) Free ii) Lateral restraint to top flange iii) Torsional restraint iv) Lateral and torsional restraint</p>	<p><math>1.0L</math> <math>0.9L</math> <math>0.8L</math> <math>0.7L</math></p>	<p><math>2.5L</math> <math>2.5L</math> <math>1.5L</math> <math>1.2L</math></p>
<p>d) Restrained laterally, torsionally and against rotation on plan</p> 	<p>i) Free ii) Lateral restraint to top flange iii) Torsional restraint iv) Lateral and torsional restraint</p>	<p><math>0.8L</math> <math>0.7L</math> <math>0.6L</math> <math>0.5L</math></p>	<p><math>1.4L</math> <math>1.4L</math> <math>0.6L</math> <math>0.5L</math></p>
<b>Top restraint conditions</b>			
<p>i) Free</p> 	<p>ii) Lateral restraint to top flange</p> 	<p>iii) Torsional restraint</p> 	<p>iv) Lateral and torsional restraint</p> 



using only simple post critical method, according to 8.4.2.2(a).

Additionally, the end panel along with the stiffeners should be checked as a beam spanning between the flanges to resist a shear force,  $R_{tf}$  and a moment,  $M_{tf}$  due to tension field forces as given in 8.5.3. Further, end stiffener should be capable of resisting the reaction plus a compressive force due to the moment, equal to  $M_{tf}$  (see Fig. 12).

**8.5.2 End Panels Designed Using Tension Field Action** (see Fig. 13 and Fig. 14)

The design of end panels in girders, which are designed using tension field action shall be carried out in accordance with the provisions mentioned herein. In this case, the end panel (Panel B) shall be designed according to 8.4.2.2(b).

Additionally it should be provided with an end post consisting of a single or double stiffener (see Fig. 13 and Fig. 14), satisfying the following:

- a) *Single stiffener* (see Fig. 13) — The top of the end post should be rigidly connected to the flange using full strength welds. The end post should be capable of resisting the reaction plus a moment from the anchor forces equal to  $2/3 M_{tf}$  due to tension field forces, where  $M_{tf}$  is obtained from 8.5.3. The width and thickness of the end post are not to exceed the width and thickness of the flange.
- b) *Double stiffener* (see Fig. 14) — The end post should be checked as a beam spanning between the flanges of the girder and capable of resisting a shear force  $R_{tf}$  and a moment,  $M_{tf}$  due to the tension field forces as given in 8.5.3.

**8.5.3 Anchor Forces**

The resultant longitudinal shear,  $R_{tf}$ , and a moment  $M_{tf}$  from the anchor of tension field forces are evaluated as given below:

$$R_{tf} = \frac{H_q}{2} \quad \text{and} \quad M_{tf} = \frac{H_q d}{10}$$

where

$$H_q = 1.25 V_p \left( 1 - \frac{V_{cr}}{V_p} \right)^{1/2}$$

$$V_p = \frac{dtf_y}{\sqrt{3}}$$

$d$  = web depth

If the actual factored shear force,  $V$  in the panel designed using tension field approach is less than the shear strength,  $V_{tf}$  as given in 8.4.2.2(b), then the values

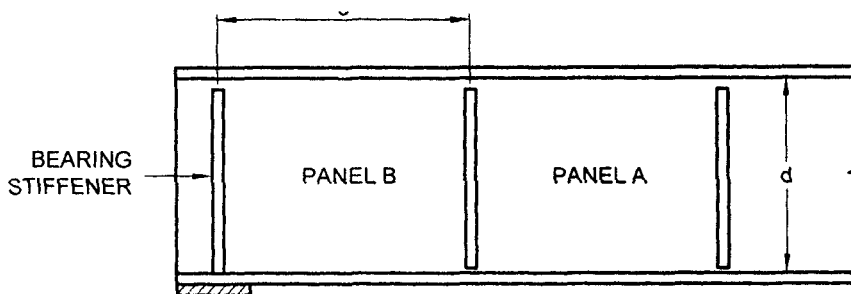
of  $H_q$  may be reduced by the ratio  $\frac{V - V_{cr}}{V_{tf} - V_{cr}}$

where

$V_{tf}$  = the basic shear strength for the panel utilizing tension field action as given in 8.4.2.2(b), and

$V_{cr}$  = critical shear strength for the panel designed utilizing tension field action as given in 8.4.2.2(a).

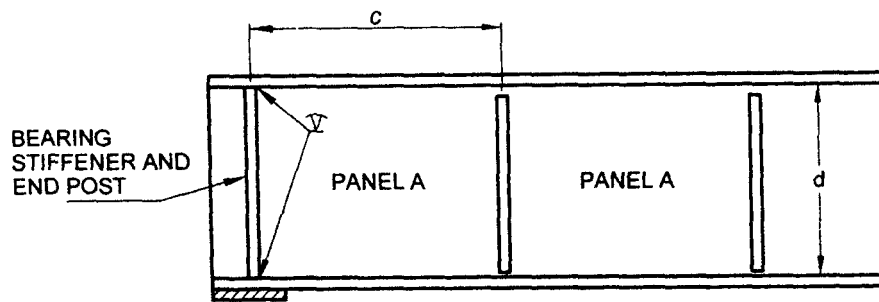
**8.5.4 Panels with Openings** — Panels with opening of dimension greater than 10 percent of the minimum panel dimension should be designed without using tension field action as given in 8.4.2.2(b). The adjacent panels should be designed as an end panel as given in 8.5.1 or 8.5.2, as appropriate.



NOTES

- 1 Panel A is designed utilizing tension field action as given in 8.4.2.2(b).
- 2 Panel B is designed without utilizing tension field action as given in 8.4.2.2(a).
- 3 Bearing stiffener is designed for the compressive force due to bearing plus compressive force due to the moment  $M_{tf}$  as given in 8.5.3.

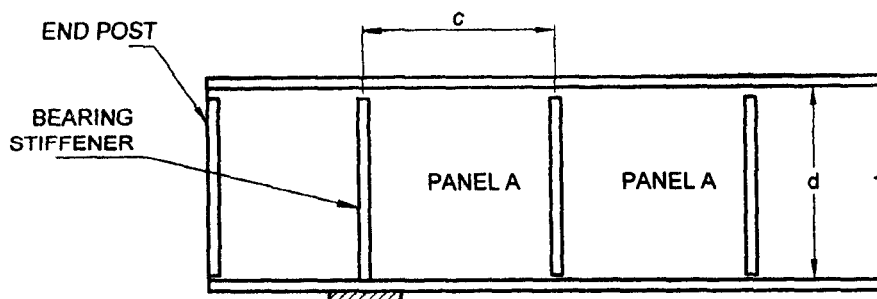
FIG. 12 END PANEL DESIGNED NOT USING TENSION FIELD ACTION



## NOTES

- 1 Panel A is designed utilizing tension field action as given in 8.4.2.2(b).
- 2 Panel B is designed utilizing tension field action as given in 8.4.2.2(b).
- 3 Bearing stiffener and end post is designed for combination of compressive loads due to bearing and a moment equal to  $2/3 M_{tr}$  as given in 8.5.3.

FIG. 13 END PANEL DESIGNED USING TENSION FIELD ACTION (SINGLE STIFFENER)



## NOTES

- 1 Panel A is designed utilizing tension field action as given in 8.4.2.2(b).
- 2 Bearing stiffener is designed for compressive force due to bearing as given in 8.4.2.2(a).
- 3 End post is designed for horizontal shear  $R_{tr}$  and moment  $M_{tr}$  as given in 8.5.3.

FIG. 14 END PANEL DESIGNED USING TENSION FIELD ACTION (DOUBLE STIFFENER)

## 8.6 Design of Beams and Plate Girders with Solid Webs

### 8.6.1 Minimum Web Thickness

The thickness of the web in a section shall satisfy the following requirements:

#### 8.6.1.1 Serviceability requirement

- a) When transverse stiffeners are not provided,

$$\frac{d}{t_w} \leq 200\epsilon \quad (\text{web connected to flanges along both longitudinal edges})$$

$$\frac{d}{t_w} \leq 90\epsilon \quad (\text{web connected to flanges along one longitudinal edge only}),$$

- b) When only transverse stiffeners are provided (in webs connected to flanges along both

longitudinal edges),

- 1) when  $3d \geq c \geq d$

$$\frac{d}{t_w} \leq 200 \epsilon$$

- 2) when  $0.74 d \leq c < d$

$$\frac{c}{t_w} \leq 200\epsilon_w$$

- 3) when  $c < d$

$$\frac{d}{t_w} \leq 270\epsilon_w$$

- 4) when  $c > 3d$ , the web shall be considered as unstiffened,

- c) When transverse stiffeners and longitudinal stiffeners at one level only are provided (0.2  $d$  from compression flange) according to 8.7.13 (a)

- 1) when  $2.4d \geq c \geq d$

$$\frac{d}{t_w} \leq 250\epsilon_w$$

- 2) when  $0.74d \leq c \leq d$

$$\frac{c}{t_w} \leq 250\epsilon_w$$

- 3) when  $c < 0.74d$

$$\frac{d}{t_w} \leq 340\epsilon_w$$

- d) When a second longitudinal stiffener (located at neutral axis is provided)

$$\frac{d}{t_w} \leq 400\epsilon_w$$

where

$d$  = depth of the web,

$t_w$  = thickness of the web,

$c$  = spacing of transverse stiffener (see Fig. 12 and Fig. 13),

$\epsilon_w$  = yield stress ratio of web =  $\sqrt{\frac{250}{f_{yw}}}$ ,

and

$f_{yw}$  = yield stress of the web.

#### 8.6.1.2 Compression flange buckling requirement

In order to avoid buckling of the compression flange into the web, the web thickness shall satisfy the following:

- a) When transverse stiffeners are not provided

$$\frac{d}{t_w} \leq 345\epsilon_f^2$$

- b) When transverse stiffeners are provided and

- 1) when  $c \geq 1.5d$

$$\frac{d}{t_w} \leq 345\epsilon_f^2$$

- 2) when  $c < 1.5d$

$$\frac{d}{t_w} \leq 345\epsilon_f$$

where

$d$  = depth of the web,

$t_w$  = thickness of the web,

$c$  = spacing of transverse stiffener (see Fig. 12 and Fig. 13),

$\epsilon_f$  = yield stress ratio of web =  $\sqrt{\frac{250}{f_{yf}}}$ ,

and

$f_{yf}$  = yield stress of compression flange.

### 8.6.2 Sectional Properties

**8.6.2.1** The effective sectional area of compression flanges shall be the gross area with deductions for excessive width of plates as specified for compression members (see Section 7) and for open holes occurring in a plane perpendicular to the direction of stress at the section being considered (see 8.2.1.4).

The effective sectional area of tension flanges shall be the gross sectional area with deductions for holes as specified in 8.2.1.4.

The effective sectional area for parts in shear shall be taken as specified in 8.4.1.1.

### 8.6.3 Flanges

**8.6.3.1** In riveted or bolted construction, flange angles shall form as large a part of the area of the flange as practicable (preferably not less than one-third) and the number of flange plates shall be kept to a minimum.

In exposed situations, where flange angles are used, at least one plate of the top flange shall extend over the full length of the girder, unless the top edge of the web is machined flush with the flange angles. Where two or more flange plates are used, tacking rivets shall be provided, if necessary to comply with the requirements of Section 10.

Each flange plate shall extend beyond its theoretical cut-off point, and the extension shall contain sufficient rivets, bolts or welds to develop in the plate, the load calculated for the bending moment on the girder section (taken to include the curtailed plate) at the theoretical cut-off point.

The outstand of flange plates, that is the projection beyond the outer line of connections to flange angles, channel or joist flanges or in the case of welded constructions their projection beyond the face of the web or tongue plate, shall not exceed the values given in 3.7.2 (see Table 2).

In the case of box girders, the thickness of any plate, or the aggregate thickness of two or more plates, when these plates are tacked together to form the flange, shall satisfy the requirements given in 3.7.2 (see Table 2).

#### 8.6.3.2 Flange splices

Flange splices should preferably, not be located at points of maximum stress. Where splice plates are used, their area shall be not less than 5 percent in excess of the area of the flange element spliced; their centre of gravity shall coincide, as nearly as possible, with that of the element spliced. There shall be enough bolts, rivets or welds on each side of the splice to develop

the load in the element spliced plus 5 percent but in no case should the strength developed be less than 50 percent of the effective strength of the material spliced. In welded construction, flange plates shall be joined by complete penetration butt welds, wherever possible. These butt welds shall develop the full strength of the plates.

#### 8.6.3.3 Connection of flanges to web

The flanges of plate girders shall be connected to the web by sufficient rivets, bolts or welds to transmit the maximum horizontal shear force resulting from the bending moment gradient in the girder, combined with any vertical loads which are directly applied to the flange. If the web is designed using tension field method as given in 8.4.2.2 (b), the weld should be able to transfer the tension field stress,  $f_{yw}$  acting on the web.

#### 8.6.3.4 Bolted/Riveted construction

For girders in exposed situations and which do not have flange plates for their entire length, the top edge of the web plate shall be flush with or above the angles, and the bottom edge of the web plate shall be flush with or set back from the angles.

#### 8.6.3.5 Welded construction

The gap between the web plates and flange plates shall be kept to a minimum and for fillet welds shall not exceed 1 mm at any point before welding.

### 8.6.4 Webs

#### 8.6.4.1 Effective sectional area of web of plate girder

The effective cross-sectional area shall be taken as the full depth of the web plate multiplied by the thickness.

NOTE — Where webs are varied in thickness in the depth of the section by the use of tongue plates or the like, or where the proportion of the web included in the flange area is 25 percent or more of the overall depth, the above approximation is not permissible and the maximum shear stress shall be computed on theory.

#### 8.6.4.2 Splices in webs

Splices and cutouts for service ducts in the webs should preferably not be located at points of maximum shear force and heavy concentrated loads.

Splices in the webs of the plate girders and rolled sections shall be designed to resist the shears and moments at the spliced section (see Annex F).

In riveted or bolted construction, splice plates shall be provided on each side of the web. In welded construction, web splices shall preferably be made with complete penetration butt welds.

8.6.4.3 Where additional plates are required to

augment the strength of the web, they shall be placed on each side of the web and shall be equal in thickness. The proportion of shear force assumed to be resisted by these plates shall be limited by the amount of horizontal shear which they can transmit to the flanges through their fastenings, and such reinforcing plates and their fastenings shall be carried up to the points at which the flange without the additional plates is adequate.

## 8.7 Stiffener Design

### 8.7.1 General

8.7.1.1 When the web of a member acting alone (that is without stiffeners) proves inadequate, stiffeners for meeting the following requirements should be provided:

- Intermediate transverse web stiffener* — To improve the buckling strength of a slender web due to shear (see 8.7.2).
- Load carrying stiffener* — To prevent local buckling of the web due to concentrated loading (see 8.7.3 and 8.7.5).
- Bearing stiffener* — To prevent local crushing of the web due to concentrated loading (see 8.7.4 and 8.7.6).
- Torsion stiffener* — To provide torsional restraint to beams and girders at supports (see 8.7.9).
- Diagonal stiffener* — To provide local reinforcement to a web under shear and bearing (see 8.7.7).
- Tension stiffener* — To transmit tensile forces applied to a web through a flange (see 8.7.8).

The same stiffeners may perform more than one function and their design should comply with the requirements of all the functions for which designed.

#### 8.7.1.2 Outstand of web stiffeners

Unless the outer edge is continuously stiffened, the outstand from the face of the web should not exceed  $20t_q\epsilon$ .

When the outstand of web is between  $14t_q\epsilon$  and  $20t_q\epsilon$ , then the stiffener design should be on the basis of a core section with an outstand of  $14t_q\epsilon$ , where  $t_q$  is the thickness of the stiffener.

#### 8.7.1.3 Stiff bearing length

The stiff bearing length of any element  $b_1$ , is that length which cannot deform appreciably in bending. To determine  $b_1$ , the dispersion of load through a steel bearing element should be taken as  $45^\circ$  through solid material, such as bearing plates, flange plates, etc (see Fig. 15).

**8.7.1.4 Eccentricity**

Where a load or reaction is applied eccentric to the centreline of the web or where the centroid of the stiffener does not lie on the centreline of the web, the resulting eccentricity of loading should be accounted for in the design of the stiffener.

**8.7.1.5 Buckling resistance of stiffeners**

The buckling resistance  $F_{qd}$  should be based on the design compressive stress  $f_{cd}$  (see 7.1.2.1) of a strut (curve  $c$ ), the radius of gyration being taken about the axis parallel to the web. The effective section is the full area or core area of the stiffener (see 8.7.1.2) together with an effective length of web on each side of the centreline of the stiffeners, limited to 20 times the web thickness. The design strength used should be the minimum value obtained for buckling about the web or the stiffener.

The effective length for intermediate transverse stiffeners used in calculating the buckling resistance,  $F_{qd}$ , should be taken as 0.7 times the length,  $L$  of the stiffener.

The effective length for load carrying web stiffeners used in calculating the buckling resistance,  $F_{xd}$ , assumes that the flange through which the load or reaction is applied is effectively restrained against lateral movement relative to the other flange, and should be taken as:

- a)  $KL = 0.7L$  when flange is restrained against rotation in the plane of the stiffener (by other structural elements).
- b)  $KL = L$ , when flange is not so restrained:

where

$$L = \text{length of the stiffener.}$$

If the load or reaction is applied to the flange by a compression member, then unless effective lateral restraint is provided at that point, the stiffener should be designed as part of the compression member applying the load, and the connection between the column and beam flange shall be checked for the effects of the strut action.

**8.7.2 Design of Intermediate Transverse Web Stiffeners**

**8.7.2.1 General**

Intermediate transverse stiffeners may be provided on one or both sides of the web.

**8.7.2.2 Spacing**

Spacing of intermediate stiffeners, where provided, shall comply with 8.6.1 depending on the thickness of the web.

**8.7.2.3 Outstand of stiffeners**

The outstand of the stiffeners should comply with 8.7.1.2.

**8.7.2.4 Minimum stiffeners**

Transverse web stiffeners not subject to external loads or moments should have a second moment of area,  $I_s$  about the centreline of the web, if stiffeners are on both sides of the web and about the face of the web, if single stiffener on only one side of the web is used such that:

$$\text{if } c/d \geq \sqrt{2}, \quad I_s \geq 0.75 dt_w^3, \text{ and}$$

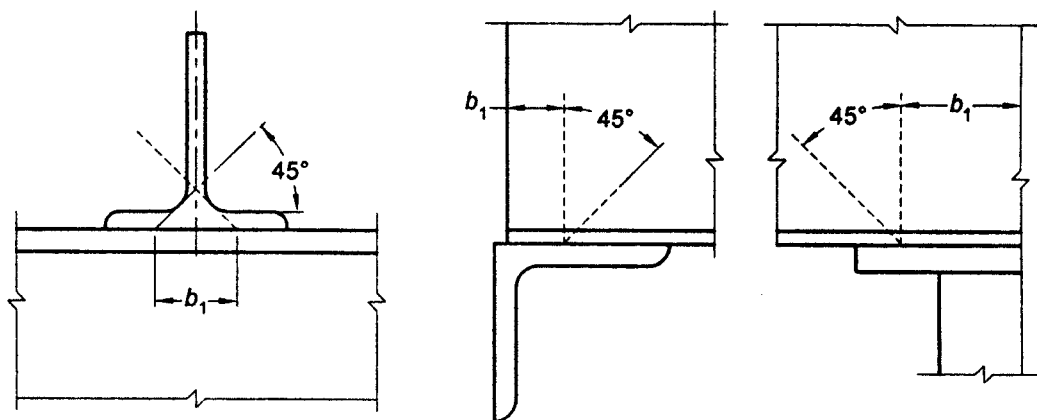


FIG. 15 STIFF BEARING LENGTH,  $b_1$

$$\text{if } c/d < \sqrt{2}, \quad I_s \geq \frac{1.5d^3 t_w^3}{c^2}$$

where

- $d$  = depth of the web;  
 $t_w$  = minimum required web thickness for spacing using tension field action, as given in 8.4.2.1; and  
 $c$  = actual stiffener spacing.

### 8.7.2.5 Buckling check on intermediate transverse web stiffeners

Stiffeners not subjected to external loads or moments should be checked for a stiffener force:

$$F_q = V - V_{cr} / \gamma_{m0} \leq F_{qd}$$

where

- $F_{qd}$  = design resistance of the intermediate stiffeners,  
 $V$  = factored shear force adjacent to the stiffener, and  
 $V_{cr}$  = shear buckling resistance of the web panel designed without using tension field action as given in 8.4.2.2(a).

Stiffeners subject to external loads and moments should meet the conditions for load carrying web stiffeners in 8.7.3. In addition they should satisfy the following interaction expression:

$$\frac{F_q - F_x}{F_{qd}} + \frac{F_x}{F_{xd}} + \frac{M_q}{M_{yq}} \leq 1$$

If  $F_q < F_x$ , then  $(F_q - F_x)$  should be taken as zero;

where

- $F_q$  = stiffener force given above;  
 $F_{qd}$  = design resistance of an intermediate web stiffener corresponding to buckling about an axis parallel to the web (see 8.7.1.5);  
 $F_x$  = external load or reaction at the stiffener;  
 $F_{xd}$  = design resistance of a load carrying stiffener corresponding to buckling about axis parallel to the web (see 8.7.1.5);  
 $M_q$  = moment on the stiffener due to eccentrically applied load and transverse load, if any; and  
 $M_{yq}$  = yield moment capacity of the stiffener based on its elastic modulus about its centroidal axis parallel to the web.

### 8.7.2.6 Connection of intermediate stiffeners to web

Intermediate transverse stiffeners not subject to external loading should be connected to the web so as to withstand a shear between each component of the stiffener and the web (in kN/mm) of not less than:

$$t_w^2 / (5b_s)$$

where

- $t_w$  = web thickness, in mm; and  
 $b_s$  = outstand width of the stiffener, in mm.

For stiffeners subject to external loading, the shear between the web and the stiffener due to such loading has to be added to the above value.

Stiffeners not subject to external loads or moments may terminate clear of the tension flange and in such a situation the distance cut short from the line of the weld should not be more than  $4t_w$ .

### 8.7.3 Load Carrying Stiffeners

#### 8.7.3.1 Web check

Load carrying web stiffeners should be provided where compressive forces applied through a flange by loads or reactions exceed the buckling strength,  $F_{cdw}$ , of the unstiffened web, calculated using the following:

The effective length of the web for evaluating the slenderness ratio is calculated as in 8.7.1.5. The area of cross-section is taken as  $(b_1 + n_1) t_w$ :

where

- $b_1$  = width of stiff bearing on the flange (see 8.7.1.3), and  
 $n_1$  = dispersion of the load through the web at 45°, to the level of half the depth of the cross-section.

The buckling strength of this web about axis parallel to the web is calculated as given in 7.1.2.1, using curve 'c'.

#### 8.7.4 Bearing Stiffeners

Bearing stiffeners should be provided for webs where forces applied through a flange by loads or reactions exceeding the local capacity of the web at its connection to the flange,  $F_w$ , given by:

$$F_w = (b_1 + n_2) t_w f_{yw} / \gamma_{m0}$$

where

- $b_1$  = stiff bearing length (see 8.7.1.3),  
 $n_2$  = length obtained by dispersion through the

flange to the web junction at a slope of 1 : 2.5 to the plane of the flange,

$t_w$  = thickness of the web, and

$f_{yw}$  = yield stress of the web.

### 8.7.5 Design of Load Carrying Stiffeners

#### 8.7.5.1 Buckling check

The external load or reaction,  $F_x$  on a stiffener should not exceed the buckling resistance,  $F_{xd}$  of the stiffener as given in 8.7.1.5.

Where the stiffener also acts as an intermediate stiffener it should be checked for the effect of combined loads in accordance with 8.7.2.5.

#### 8.7.5.2 Bearing check

Load carrying web stiffeners should also be of sufficient size that the bearing strength of the stiffener,  $F_{psd}$ , given below is not less than the load transferred,  $F_x$

$$F_{psd} = A_q f_{yq} / (0.8 \gamma_{m0}) \geq F_x$$

where

$F_x$  = external load or reaction,

$A_q$  = area of the stiffener in contact with the flange, and

$f_{yq}$  = yield stress of the stiffener.

### 8.7.6 Design of Bearing Stiffeners

Bearing stiffeners should be designed for the applied load or reaction less the local capacity of the web as given in 8.7.4. Where the web and the stiffener material are of different strengths the lesser value should be assumed to calculate the capacity of the web and the stiffener. Bearing stiffeners should project nearly as much as the overhang of the flange through which load is transferred.

### 8.7.7 Design of Diagonal Stiffeners

Diagonal stiffeners should be designed to carry the portion of the applied shear and bearing that exceeds the capacity of the web.

Where the web and the stiffener are of different strengths, the value for design should be taken as given in 8.7.6.

### 8.7.8 Design of Tension Stiffeners

Tension stiffeners should be designed to carry the portion of the applied load or reaction less the capacity of the web as given in 8.7.4 for bearing stiffeners.

Where the web and the stiffener are of different strengths, the value for design should be taken as given in 8.7.6.

### 8.7.9 Torsional Stiffeners

Where bearing stiffeners are required to provide torsional restraint at the supports of the beam, they should meet the following criteria:

- Conditions of 8.7.4, and
- Second moment of area of the stiffener section about the centreline of the web,  $I_s$  should be such that:

$$I_s \geq 0.34 \alpha_s D^3 T_{cf}$$

where

$$\begin{aligned} \alpha_s &= 0.006 \text{ for } L_{LT}/r_y \leq 50, \\ &= 0.3/(L_{LT}/r_y) \text{ for } 50 < L_{LT}/r_y \leq 100, \\ &= 30/(L_{LT}/r_y)^2 \text{ for } L_{LT}/r_y > 100, \end{aligned}$$

$D$  = overall depth of beam at support,

$T_{cf}$  = maximum thickness of compression flange in the span under consideration,

$KL$  = laterally unsupported effective length of the compression flange of the beam, and

$r_y$  = radius of gyration of the beam about the minor axis.

### 8.7.10 Connection to Web of Load Carrying and Bearing Stiffeners

Stiffeners, which resist loads or reactions applied through a flange, should be connected to the web by sufficient welds or fasteners to transmit a design force equal to the lesser of:

- tension capacity of the stiffener; and
- sum of the forces applied at the two ends of the stiffener when they act in the same direction or the larger of the forces when they act in opposite directions.

Stiffeners, which do not extend right across the web, should be of such length that the shear stress in the web due to the design force transmitted by the stiffener does not exceed the shear strength of the web. In addition, the capacity of the web beyond the end of the stiffener should be sufficient to resist the applied force.

### 8.7.11 Connection to Flanges

#### 8.7.11.1 In tension

Stiffeners required to resist tension should be connected to the flange transmitting the load by continuous welds or non-slip fasteners.

#### 8.7.11.2 In compression

Stiffeners required to resist compression should

either be fitted against the loaded flange or connected by continuous welds or non-slip fasteners.

The stiffener should be fitted against or connected to both flanges when:

- a) a load is applied directly over a support, or
- b) it forms the end stiffener of a stiffened web, or
- c) it acts as a torsion stiffener.

#### 8.7.12 Hollow Sections

Where concentrated loads are applied to hollow sections consideration should be given to local stresses and deformations and the section reinforced as necessary.

#### 8.7.13 Horizontal Stiffeners

Where horizontal stiffeners are used in addition to vertical stiffeners, they shall be as follows:

- a) One horizontal stiffener shall be placed on the web at a distance from the compression flange equal to  $1/5$  of the distance from the compression flange angle, plate or tongue plate to the neutral axis when the thickness of the web is less than the limits specified in 8.6.1. The stiffener shall be designed so that  $I_s$  is not less than  $4ct_w^3$  where  $I_s$  and  $t_w$  are as defined in 8.7.2.4 and  $c$  is the actual distance between the vertical stiffeners
- b) A second horizontal stiffener (single or double) shall be placed at the neutral axis of the girder when the thickness of the web is less than the limit specified in 8.6.1. This stiffener shall be designed so that  $I_s$  is not less than  $d_2 t_w^3$  where  $I_s$  and  $t_w$  are as defined in 8.7.2.4 and  $d_2$  is twice the clear distance from the compression flange angles, plates or tongue plates to the neutral axis;
- c) Horizontal web stiffeners shall extend between vertical stiffeners, but need not be continuous over them; and
- d) Horizontal stiffeners may be in pairs arranged on each side of the web, or single located on one side of the web.

#### 8.8 Box Girders

The design and detailing of box girders shall be such as to give full advantage of its higher load carrying capacity. Box girder shall be designed in accordance with specialist literature. The diaphragms and horizontal stiffeners should conform to 8.7.12 and 8.7.13.

8.8.1 All diaphragms shall be connected such as to transfer the resultant shears to the web and flanges.

8.8.2 Where the concentrated or moving load does not act directly on top of the web, the local effect shall be considered in the design of flanges and the diaphragms.

#### 8.9 Purlins and Sheeting Rails (Girts)

All purlins shall be designed in accordance with the requirements for uncased beams as specified in 8.2.1 and 8.2.2, and the limitations of bending stress based on lateral instability of the compression flange and the limiting deflection specified under 5.6.1 for the design of purlins. The maximum bending moment shall not exceed the values specified in 8.2.1. The calculated deflections should not exceed those permitted for the type of roof cladding used as specified in 5.6.1. In calculating the bending moment, advantage may be taken of the continuity of the purlin over supports. The bending about the two axes should be determined separately and checked according to the biaxial bending requirements specified in Section 9.

#### 8.10 Bending in a Non-principal Plane

8.10.1 When the flexural deflection of a member is constrained to a non-principal plane by lateral restraints preventing lateral deflection, then the force exerted by the restraints shall be determined, and the principal axes bending moments acting on the member shall be calculated from these forces and applied forces, by a rational analysis. The combined effect of bending about the principal axes shall satisfy the requirements of Section 9.

8.10.2 When the deflections of a member loaded in a non-principal plane are unconstrained; the principal axes bending moments shall be calculated by a rational analysis. The combined effect of bending about the principal axes shall satisfy the requirements of Section 9.

### SECTION 9 MEMBER SUBJECTED TO COMBINED FORCES

#### 9.1 General

This section governs the design of members subjected to combined forces, such as shear force and bending, axial force and bending, or shear force, axial force and bending.

#### 9.2 Combined Shear and Bending

9.2.1 No reduction in moment capacity of the section is necessary as long as the cross-section is not subjected to high shear force (factored value of applied shear force is less than or equal to 60 percent of the shear strength of the section as given in 8.4). The moment capacity may be taken as,  $M_d$  (see 8.2) without any reduction.



9.2.2 When the factored value of the applied shear force is high (exceeds the limit specified in 9.2.1), the factored moment of the section should be less than the moment capacity of the section under higher shear force,  $M_{dv}$ , calculated as given below:

a) *Plastic or Compact Section*

$$M_{dv} = M_d - \beta(M_d - M_{fd}) \leq 1.2 Z_e f_y / \gamma_{m0}$$

where

$$\beta = (2V / V_d - 1)^2$$

$M_d$  = plastic design moment of the whole section disregarding high shear force effect (see 8.2.1.2) considering web buckling effects (see 8.2.1.1),

$V$  = factored applied shear force as governed by web yielding or web buckling,

$V_d$  = design shear strength as governed by web yielding or web buckling (see 8.4.1 or 8.4.2),

$M_{fd}$  = plastic design strength of the area of the cross-section excluding the shear area, considering partial safety factor  $\gamma_{m0}$ , and

$Z_e$  = elastic section modulus of the whole section.

b) *Semi-compact Section*

$$M_{dv} = Z_e f_y / \gamma_{m0}$$

### 9.3 Combined Axial Force and Bending Moment

Under combined axial force and bending moment, section strength as governed by material failure and member strength as governed by buckling failure shall be checked in accordance with 9.3.1 and 9.3.2 respectively.

#### 9.3.1 Section Strength

##### 9.3.1.1 Plastic and compact sections

In the design of members subjected to combined axial force (tension or compression) and bending moment, the following should be satisfied:

$$\left( \frac{M_y}{M_{ndy}} \right)^{\alpha_1} + \left( \frac{M_z}{M_{ndz}} \right)^{\alpha_2} \leq 1.0$$

Conservatively, the following equation may also be used under combined axial force and bending moment:

$$\frac{N}{N_d} + \frac{M_y}{M_{dy}} + \frac{M_z}{M_{dz}} \leq 1.0$$

where

$M_y, M_z$  = factored applied moments about the minor and major axis of the cross-section, respectively;

$M_{ndy}, M_{ndz}$  = design reduced flexural strength under combined axial force and the respective uniaxial moment acting alone (see 9.3.1.2);

$N$  = factored applied axial force (Tension,  $T$  or Compression,  $P$ );

$N_d$  = design strength in tension,  $T_d$  as obtained from 6 or in compression due to yielding given by  $N_d = A_g f_y / \gamma_{m0}$ ;

$M_{dy}, M_{dz}$  = design strength under corresponding moment acting alone (see 8.2);

$A_g$  = gross area of the cross-section;

$\alpha_1, \alpha_2$  = constants as given in Table 17; and

$\gamma_{m0}$  = partial factor of safety in yielding.

9.3.1.2 For plastic and compact sections without bolts holes, the following approximations may be used for evaluating  $M_{ndy}$  and  $M_{ndz}$ :

a) *Plates*

$$M_{nd} = M_d (1 - n^2)$$

b) *Welded I or H sections*

$$M_{ndy} = M_{dy} \left[ 1 - \left( \frac{n-a}{1-a} \right)^2 \right] \leq M_{dy} \text{ where } n \geq a$$

$$M_{ndz} = M_{dz} (1 - n) / (1 - 0.5a) \leq M_{dz}$$

where

$$n = N / N_d \quad \text{and } a = (A - 2 b t_f) / A \leq 0.5$$

c) *For standard I or H sections*

$$\text{for } n \leq 0.2 \quad M_{ndy} = M_{dy}$$

$$\text{for } n > 0.2 \quad M_{ndy} = 1.56 M_{dy} (1 - n) (n + 0.6)$$

$$M_{ndz} = 1.11 M_{dz} (1 - n) \leq M_{dz}$$

d) *For rectangular hollow sections and welded box sections*

When the section is symmetric about both axes and without bolt holes

$$M_{ndy} = M_{dy} (1 - n) / (1 - 0.5a_f) \leq M_{dy}$$

$$M_{ndz} = M_{dz} (1 - n) / (1 - 0.5a_w) \leq M_{dz}$$

where

$$a_w = (A - 2 b t_f) / A \leq 0.5$$

$$a_f = (A - 2 h t_w) / A \leq 0.5$$

e) *Circular hollow tubes without bolt holes*

$$M_{nd} = 1.04 M_d (1 - n^{1.7}) \leq M_d$$

**9.3.1.3 Semi-compact section**

In the absence of high shear force (see 9.2.1), semi-compact section design is satisfactory under combined axial force and bending, if the maximum longitudinal stress under combined axial force and bending,  $f_x$  satisfies the following criteria:

$$f_x \leq f_y / \gamma_{m0}$$

For cross-section without holes, the above criteria reduces to,

$$\frac{N}{N_d} + \frac{M_y}{M_{dy}} + \frac{M_z}{M_{dz}} \leq 1.0$$

where

$N_d, M_{dy}, M_{dz}$  are as defined in 9.3.1.1.

**Table 17 Constants  $\alpha_1$  and  $\alpha_2$**

(Clause 9.3.1.1)

Sl No.	Section	$\alpha_1$	$\alpha_2$
(1)	(2)	(3)	(4)
i)	I and channel	$5n \geq 1$	2
ii)	Circular tubes	2	2
iii)	Rectangular tubes	$1.66/ (1-1.13n^2) \leq 6$	$1.66/ (1-1.13n^2) \leq 6$
iv)	Solid rectangles	$1.73+1.8n^3$	$1.73+1.8n^3$

NOTE —  $n = N/N_d$ .

**9.3.2 Overall Member Strength**

Members subjected to combined axial force and bending moment shall be checked for overall buckling failure as given in this section.

**9.3.2.1 Bending and axial tension**

The reduced effective moment,  $M_{eff}$ , under tension and bending calculated as given below, should not exceed the bending strength due to lateral torsional buckling,  $M_d$  (see 8.2.2).

$$M_{eff} = [M - \psi T Z_{ec} / A] \leq M_d$$

where

$M, T$  = factored applied moment and tension, respectively;

$A$  = area of cross-section;

$Z_{ec}$  = elastic section modulus of the section

with respect to extreme compression fibre; and

$\psi = 0.8$ , if  $T$  and  $M$  can vary independently, or otherwise

$= 1.0$ .

**9.3.2.2 Bending and axial compression**

Members subjected to combined axial compression and biaxial bending shall satisfy the following interaction relationships:

$$\frac{P}{P_{dy}} + K_y \frac{C_{my} M_y}{M_{dy}} + K_{LT} \frac{M_z}{M_{dz}} \leq 1.0$$

$$\frac{P}{P_{dz}} + 0.6 K_y \frac{C_{my} M_y}{M_{dy}} + K_z \frac{C_{mz} M_z}{M_{dz}} \leq 1.0$$

where

$C_{my}, C_{mz}$  = equivalent uniform moment factor as per Table 18;

$P$  = applied axial compression under factored load;

$M_y, M_z$  = maximum factored applied bending moments about y and z-axis of the member, respectively;

$P_{dy}, P_{dz}$  = design strength under axial compression as governed by buckling about minor (y) and major (z) axis respectively;

$M_{dy}, M_{dz}$  = design bending strength about y (minor) or z (major) axis considering laterally unsupported length of the cross-section (see Section 8);

$$K_y = 1 + (\lambda_y - 0.2)n_y \leq 1 + 0.8 n_y;$$

$$K_z = 1 + (\lambda_z - 0.2)n_z \leq 1 + 0.8 n_z; \text{ and}$$

$$K_{LT} = 1 - \frac{0.1 \lambda_{LT} n_y}{(C_{mLT} - 0.25)} \geq 1 - \frac{0.1 n_y}{(C_{mLT} - 0.25)}.$$

where

$n_y, n_z$  = ratio of actual applied axial force to the design axial strength for buckling about the y and z axis, respectively, and

$C_{mLT}$  = equivalent uniform moment factor for lateral torsional buckling as per Table 18 corresponding to the actual moment gradient between lateral supports against torsional deformation in the critical region under consideration.

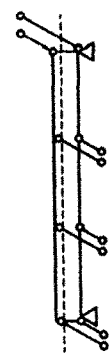
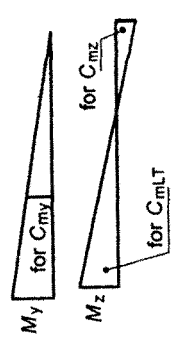
Table 18 Equivalent Uniform Moment Factor  
(Clause 9.3.2.2)

Bending Moment Diagram (1)	Range (2)	C <sub>my</sub> , C <sub>mz</sub> , C <sub>mLT</sub>	
		Uniform Loading (3)	Concentrated Load (4)
	-1 ≤ ψ ≤ 1	0.6 + 0.4 ψ ≥ 0.4	
	0 ≤ αs ≤ 1	0.2 + 0.8 αs ≥ 0.4	0.2 + 0.8 αs ≥ 0.4
	0 ≤ ψ ≤ 1	0.1 - 0.8 αs ≥ 0.4	-0.8 αs ≥ 0.4
	-1 ≤ ψ ≤ 0	0.1(1 - ψ) - 0.8 αs ≥ 0.4	0.2(1 - ψ) - 0.8 αs ≥ 0.4
	0 ≤ αs ≤ 1	0.095 - 0.05 αh	0.90 + 0.10 αh
	0 ≤ ψ ≤ 1	0.095 + 0.05 αh	0.90 + 0.10 αh
	-1 ≤ ψ ≤ 0	0.95 + 0.05 αh (1 + 2 ψ)	0.90 + 0.05 αh (1 + 2 ψ)

For members with sway buckling mode, the equivalent uniform moment factor C<sub>my</sub> = C<sub>mz</sub> = 0.9.

C<sub>my</sub>, C<sub>mz</sub>, C<sub>mLT</sub> shall be obtained according to the bending moment diagram between the relevant braced points

Moment factor	Bending axis	Points braced in direction
C <sub>my</sub>	z-z	y-y
C <sub>mz</sub>	y-y	z-z
C <sub>mLT</sub>	z-z	z-z

## SECTION 10 CONNECTIONS

### 10.1 General

**10.1.1** This section deals with the design and detailing requirements for joints between members. Connection elements consist of components such as cleats, gusset plates, brackets, connecting plates and connectors such as rivets, bolts, pins, and welds. The connections in a structure shall be designed so as to be consistent with the assumptions made in the analysis of the structure and comply with the requirements specified in this section. Connections shall be capable of transmitting the calculated design actions.

**10.1.2** Where members are connected to the surface of a web or the flange of a section, the ability of the web or the flange to transfer the applied forces locally should be checked and where necessary, local stiffening provided.

**10.1.3** Ease of fabrication and erection should be considered in the design of connections. Attention should be paid to clearances necessary for field erection, tolerances, tightening of fasteners, welding procedures, subsequent inspection, surface treatment and maintenance.

**10.1.4** The ductility of steel assists the distribution of forces generated within a joint. Effects of residual stresses and stresses due to tightening of fasteners and normal tolerances of fit-up need not therefore be considered in connection design, provided ductile behaviour is ensured.

**10.1.5** In general, use of different forms of fasteners to transfer the same force shall be avoided. However, when different forms of fasteners are used to carry a shear load or when welding and fasteners are combined, then one form of fastener shall be normally designed to carry the total load. Nevertheless, fully tensioned friction grip bolts may be designed to share the load with welding, provided the bolts are fully

tightened to develop necessary pretension after welding.

**10.1.6** The partial safety factor in the evaluation of design strength of connections shall be taken as given in Table 5.

### 10.2 Location Details of Fasteners

#### 10.2.1 Clearances for Holes for Fasteners

Bolts may be located in standard size, over size, short slotted or long slotted hole.

- Standard clearance hole* — Except where fitted bolts, bolts in low-clearance or oversize holes are specified, the diameter of standard clearance holes for fasteners shall be as given in Table 19.
- Over size hole* — Holes of size larger than the standard clearance holes, as given in Table 19 may be used in slip resistant connections and hold down bolted connections, only where specified, provided the over size holes in the outer ply is covered by a cover plate of sufficiently large size and thickness and having a hole not larger than the standard clearance hole (and hardened washer in slip resistant connections).
- Short and long slots* — Slotted holes of size larger than the standard clearance hole, as given in Table 19 may be used in slip resistant connections and hold down bolted connections, only where specified, provided the over size holes in the outer ply is covered by a cover plate of sufficiently large size and thickness and having a hole of size not larger than the standard clearance hole (and hardened washer in slip resistant connection).

#### 10.2.2 Minimum Spacing

The distance between centre of fasteners shall not be less than 2.5 times the nominal diameter of the fastener.

**Table 19 Clearances for Fastener Holes**

(Clause 10.2.1)

Sl No.	Nominal Size of Fastener, $d$ mm	Size of the Hole = Nominal Diameter of the Fastener + Clearances mm			
		Standard Clearance in Diameter and Width of Slot	Over Size Clearance in Diameter	Clearance in the Length of the Slot	
(1)	(2)	(3)	(4)	Short Slot (5)	Long Slot (6)
i)	12 – 14	1.0	3.0	4.0	2.5 $d$
ii)	16 – 22	2.0	4.0	6.0	2.5 $d$
iii)	24	2.0	6.0	8.0	2.5 $d$
iv)	Larger than 24	3.0	8.0	10.0	2.5 $d$

### 10.2.3 Maximum Spacing

**10.2.3.1** The distance between the centres of any two adjacent fasteners shall not exceed  $32t$  or 300 mm, whichever is less, where  $t$  is the thickness of the thinner plate.

**10.2.3.2** The distance between the centres of two adjacent fasteners (pitch) in a line lying in the direction of stress, shall not exceed  $16t$  or 200 mm, whichever is less, in tension members and  $12t$  or 200 mm, whichever is less, in compression members; where  $t$  is the thickness of the thinner plate. In the case of compression members wherein forces are transferred through butting faces, this distance shall not exceed 4.5 times the diameter of the fasteners for a distance equal to 1.5 times the width of the member from the butting faces.

**10.2.3.3** The distance between the centres of any two consecutive fasteners in a line adjacent and parallel to an edge of an outside plate shall not exceed 100 mm plus  $4t$  or 200 mm, whichever is less, in compression and tension members; where  $t$  is the thickness of the thinner outside plate.

**10.2.3.4** When fasteners are staggered at equal intervals and the gauge does not exceed 75 mm, the spacing specified in **10.2.3.2** and **10.2.3.3** between centres of fasteners may be increased by 50 percent, subject to the maximum spacing specified in **10.2.3.1**.

### 10.2.4 Edge and End Distances

**10.2.4.1** The edge distance is the distance at right angles to the direction of stress from the centre of a hole to the adjacent edge. The end distance is the distance in the direction of stress from the centre of a hole to the end of the element.

In slotted holes, the edge and end distances should be measured from the edge or end of the material to the centre of its end radius or the centre line of the slot, whichever is smaller. In oversize holes, the edge and end distances should be taken as the distance from the relevant edge/end plus half the diameter of the standard clearance hole corresponding to the fastener, less the nominal diameter of the oversize hole.

**10.2.4.2** The minimum edge and end distances from the centre of any hole to the nearest edge of a plate shall not be less than 1.7 times the hole diameter in case of sheared or hand-flame cut edges; and 1.5 times the hole diameter in case of rolled, machine-flame cut, sawn and planed edges.

**10.2.4.3** The maximum edge distance to the nearest line of fasteners from an edge of any un-stiffened part should not exceed  $12 t\epsilon$ , where  $\epsilon = (250/f_y)^{1/2}$  and  $t$  is the thickness of the thinner outer plate. This would

not apply to fasteners interconnecting the components of back to back tension members. Where the members are exposed to corrosive influences, the maximum edge distance shall not exceed 40 mm plus  $4t$ , where  $t$  is the thickness of thinner connected plate.

### 10.2.5 Tacking Fasteners

**10.2.5.1** In case of members covered under **10.2.4.3**, when the maximum distance between centres of two adjacent fasteners as specified in **10.2.4.3** is exceeded, tacking fasteners not subjected to calculated stress shall be used.

**10.2.5.2** Tacking fasteners shall have spacing in a line not exceeding 32 times the thickness of the thinner outside plate or 300 mm, whichever is less. Where the plates are exposed to the weather, the spacing in line shall not exceed 16 times the thickness of the thinner outside plate or 200 mm, whichever is less. In both cases, the distance between the lines of fasteners shall not be greater than the respective pitches.

**10.2.5.3** All the requirements specified in **10.2.5.2** shall generally apply to compression members, subject to the stipulations in Section 7 affecting the design and construction of compression members.

**10.2.5.4** In tension members (*see* Section 6) composed of two flats, angles, channels or tees in contact back to back or separated back to back by a distance not exceeding the aggregate thickness of the connected parts, tacking fasteners with solid distance pieces shall be provided at a spacing in line not exceeding 1 000 mm.

**10.2.5.5** For compression members covered in Section 7, tacking fasteners in a line shall be spaced at a distance not exceeding 600 mm.

### 10.2.6 Countersunk Heads

For countersunk heads, one-half of the depth of the countersinking shall be neglected in calculating the length of the fastener in bearing in accordance with **10.3.3**. For fasteners in tension having countersunk heads, the tensile strength shall be reduced by 33.3 percent. No reduction is required to be made in shear strength calculations.

## 10.3 Bearing Type Bolts

### 10.3.1 Effective Areas of Bolts

**10.3.1.1** Since threads can occur in the shear plane, the area  $A_e$  for resisting shear should normally be taken as the net tensile stress area,  $A_n$  of the bolts. For bolts where the net tensile stress area is not defined,  $A_n$  shall be taken as the area at the root of the threads.

**10.3.1.2** Where it can be shown that the threads do not occur in the shear plane,  $A_e$  may be taken as the cross section area,  $A_s$  at the shank.

**10.3.1.3** In the calculation of thread length, allowance should be made for tolerance and thread run off.

**10.3.2** A bolt subjected to a factored shear force ( $V_{sb}$ ) shall satisfy the condition

$$V_{sb} = V_{db}$$

where  $V_{db}$  is the design strength of the bolt taken as the smaller of the value as governed by shear,  $V_{dsb}$  (see 10.3.3) and bearing,  $V_{dpsb}$  (see 10.3.4).

**10.3.3 Shear Capacity of Bolt**

The design strength of the bolt,  $V_{dsb}$  as governed shear strength is given by:

$$V_{dsb} = V_{nsb} / \gamma_{mb}$$

where

$V_{nsb}$  = nominal shear capacity of a bolt, calculated as follows:

$$V_{nsb} = \frac{f_u}{\sqrt{3}} (n_n A_{nb} + n_s A_{sb})$$

where

- $f_u$  = ultimate tensile strength of a bolt;
- $n_n$  = number of shear planes with threads intercepting the shear plane;
- $n_s$  = number of shear planes without threads intercepting the shear plane;
- $A_{sb}$  = nominal plain shank area of the bolt; and
- $A_{nb}$  = net shear area of the bolt at threads, may be taken as the area corresponding to root diameter at the thread.

**10.3.3.1 Long joints**

When the length of the joint,  $l_j$  of a splice or end connection in a compression or tension element containing more than two bolts (that is the distance between the first and last rows of bolts in the joint, measured in the direction of the load transfer) exceeds  $15d$  in the direction of load, the nominal shear capacity (see 10.3.2),  $V_{db}$  shall be reduced by the factor  $\beta_{lj}$ , given by:

$$\beta_{lj} = 1.075 - l_j / (200 d) \text{ but } 0.75 \leq \beta_{lj} \leq 1.0$$

$$= 1.075 - 0.005(l_j / d)$$

where

$d$  = Nominal diameter of the fastener.

NOTE — This provision does not apply when the distribution of shear over the length of joint is uniform, as in the connection of web of a section to the flanges.

**10.3.3.2 Large grip lengths**

When the grip length,  $l_g$  (equal to the total thickness of

the connected plates) exceeds 5 times the diameter,  $d$  of the bolts, the design shear capacity shall be reduced by a factor  $\beta_{lg}$ , given by:

$$\beta_{lg} = 8 d / (3 d + l_g) = 8 / (3 + l_g / d)$$

$\beta_{lg}$  shall not be more than  $\beta_{lj}$  given in 10.3.3.1. The grip length,  $l_g$  shall in no case be greater than  $8d$ .

**10.3.3.3 Packing plates**

The design shear capacity of bolts carrying shear through a packing plate in excess of 6 mm shall be decreased by a factor,  $\beta_{pk}$  given by:

$$\beta_{pk} = (1 - 0.0125 t_{pk})$$

where

$t_{pk}$  = thickness of the thicker packing, in mm.

**10.3.4 Bearing Capacity of the Bolt**

The design bearing strength of a bolt on any plate,  $V_{dpsb}$  as governed by bearing is given by:

$$V_{dpsb} = V_{npb} / \gamma_{mb}$$

where

$$V_{npb} = \text{nominal bearing strength of a bolt}$$

$$= 2.5 k_b d t f_u$$

where

$$k_b \text{ is smaller of } \frac{e}{3d_0}, \frac{p}{3d_0} - 0.25, \frac{f_{ub}}{f_u}, 1.0;$$

$e, p$  = end and pitch distances of the fastener along bearing direction;

$d_0$  = diameter of the hole;

$f_{ub}, f_u$  = ultimate tensile stress of the bolt and the ultimate tensile stress of the plate, respectively;

$d$  = nominal diameter of the bolt; and

$t$  = summation of the thicknesses of the connected plates experiencing bearing stress in the same direction, or if the bolts are countersunk, the thickness of the plate minus one half of the depth of countersinking.

The bearing resistance (in the direction normal to the slots in slotted holes) of bolts in holes other than standard clearance holes may be reduced by multiplying the bearing resistance obtained as above,  $V_{npb}$ , by the factors given below:

- a) Over size and short slotted holes – 0.7, and
- b) Long slotted holes – 0.5.

NOTE — The block shear of the edge distance due to bearing force may be checked as given in 6.4.

### 10.3.5 Tension Capacity

A bolt subjected to a factored tensile force,  $T_b$  shall satisfy:

$$T_b \leq T_{db}$$

where

$$T_{db} = T_{nb} / \gamma_{mb}$$

$T_{nb}$  = nominal tensile capacity of the bolt, calculated as:

$$0.90 f_{ub} A_n < f_{yb} A_{sb} (\gamma_{mb} / \gamma_{m0})$$

where

$f_{ub}$  = ultimate tensile stress of the bolt,

$f_{yb}$  = yield stress of the bolt,

$A_n$  = net tensile stress area as specified in the appropriate Indian Standard (for bolts where the tensile stress area is not defined,  $A_n$  shall be taken as the area at the bottom of the threads), and

$A_{sb}$  = shank area of the bolt.

### 10.3.6 Bolt Subjected to Combined Shear and Tension

A bolt required to resist both design shear force ( $V_{sd}$ ) and design tensile force ( $T_b$ ) at the same time shall satisfy:

$$\left( \frac{V_{sb}}{V_{db}} \right)^2 + \left( \frac{T_b}{T_{db}} \right)^2 \leq 1.0$$

where

$V_{sb}$  = factored shear force acting on the bolt,

$V_{db}$  = design shear capacity (see 10.3.2),

$T_b$  = factored tensile force acting on the bolt, and

$T_{db}$  = design tension capacity (see 10.3.5).

## 10.4 Friction Grip Type Bolting

**10.4.1** In friction grip type bolting, initial pretension in bolt (usually high strength) develops clamping force at the interfaces of elements being joined. The frictional resistance to slip between the plate surfaces subjected to clamping force opposes slip due to externally applied shear. Friction grip type bolts and nuts shall conform to IS 3757. Their installation procedures shall conform to IS 4000.

**10.4.2** Where slip between bolted plates cannot be tolerated at working loads (slip critical connections), the requirements of 10.4.3 shall be satisfied. However, at ultimate loads, the requirements of 10.4.4 shall be satisfied by all connections.

### 10.4.3 Slip Resistance

Design for friction type bolting in which slip is required

to be limited, a bolt subjected only to a factored design shear force,  $V_{sf}$  in the interface of connections at which slip cannot be tolerated, shall satisfy the following:

$$V_{sf} \leq V_{dsf}$$

where

$$V_{dsf} = V_{nsf} / \gamma_{mf}$$

$V_{nsf}$  = nominal shear capacity of a bolt as governed by slip for friction type connection, calculated as follows:

$$V_{nsf} = \mu_f n_e K_h F_o$$

where

$\mu_f$  = coefficient of friction (slip factor) as specified in Table 20 ( $\mu_f = 0.55$ ),

$n_e$  = number of effective interfaces offering frictional resistance to slip,

$K_h = 1.0$  for fasteners in clearance holes,

= 0.85 for fasteners in oversized and short slotted holes and for fasteners in long slotted holes loaded perpendicular to the slot,

= 0.7 for fasteners in long slotted holes loaded parallel to the slot,

$\gamma_{mf} = 1.10$  (if slip resistance is designed at service load),

= 1.25 (if slip resistance is designed at ultimate load),

$F_o$  = minimum bolt tension (proof load) at installation and may be taken as  $A_{nb} f_o$ ,

$A_{nb}$  = net area of the bolt at threads, and

$f_o$  = proof stress (=  $0.70 f_{ub}$ ).

NOTE —  $V_{ns}$  may be evaluated at a service load or ultimate load using appropriate partial safety factors, depending upon whether slip resistance is required at service load or ultimate load.

### 10.4.3.1 Long joints

The provision for the long joints in 10.3.3.1 shall apply to friction grip connections also.

### 10.4.4 Capacity after slipping

When friction type bolts are designed not to slip only under service loads, the design capacity at ultimate load may be calculated as per bearing type connection (see 10.3.2 and 10.3.3).

NOTE — The block shear resistance of the edge distance due to bearing force may be checked as given in 6.4.

### 10.4.5 Tension Resistance

A friction bolt subjected to a factored tension force ( $T_f$ ) shall satisfy:

$$T_f \leq T_{df}$$

where

$$T_{df} = T_{nf} / \gamma_{mf}$$

$T_{nf}$  = nominal tensile strength of the friction bolt, calculated as:

$$0.9 f_{ub} A_n \leq f_{yb} A_{sb} (\gamma_{mf} / \gamma_m)$$

where

$f_{ub}$  = ultimate tensile stress of the bolt;

$A_n$  = net tensile stress area as specified in various parts of IS 1367 (for bolts where the tensile stress area is not defined,  $A_n$  shall be taken as the area at the root of the threads);

$A_{sb}$  = shank area of the bolt; and

$\gamma_{mf}$  = partial factor of safety.

**Table 20 Typical Average Values for Coefficient of Friction ( $\mu_f$ )**  
(Clause 10.4.3)

Sl No.	Treatment of Surface	Coefficient of Friction, $\mu_f$
(1)	(2)	(3)
i)	Surfaces not treated	0.20
ii)	Surfaces blasted with short or grit with any loose rust removed, no pitting	0.50
iii)	Surfaces blasted with shot or grit and hot-dip galvanized	0.10
iv)	Surfaces blasted with shot or grit and spray metallized with zinc (thickness 50–70 $\mu\text{m}$ )	0.25
v)	Surfaces blasted with shot or grit and painted with ethylzinc silicate coat (thickness 30–60 $\mu\text{m}$ )	0.30
vi)	Sand blasted surface, after light rusting	0.52
vii)	Surfaces blasted with shot or grit and painted with ethylzinc silicate coat (thickness 60–80 $\mu\text{m}$ )	0.30
viii)	Surfaces blasted with shot or grit and painted with alcaizinc silicate coat (thickness 60–80 $\mu\text{m}$ )	0.30
ix)	Surface blasted with shot or grit and spray metallized with aluminium (thickness > 50 $\mu\text{m}$ )	0.50
x)	Clean mill scale	0.33
xi)	Sand blasted surface	0.48
xii)	Red lead painted surface	0.1

**10.4.6 Combined Shear and Tension**

Bolts in a connection for which slip in the serviceability limit state shall be limited, which are subjected to a tension force,  $T$ , and shear force,  $V$ , shall satisfy:

$$\left(\frac{V_{sf}}{V_{df}}\right)^2 + \left(\frac{T_f}{T_{df}}\right)^2 \leq 1.0$$

where

$V_{sf}$  = applied factored shear at design load,

$V_{df}$  = design shear strength,

$T_f$  = externally applied factored tension at design load, and

$T_{df}$  = design tension strength.

**10.4.7** Where prying force,  $Q$  as illustrated in Fig. 16 is significant, it shall be calculated as given below and added to the tension in the bolt.

$$Q = \frac{l_v}{2l_e} \left[ T_e - \frac{\beta \eta f_o b_e t^4}{27 l_e l_v^2} \right]$$

where

$l_v$  = distance from the bolt centreline to the toe of the fillet weld or to half the root radius for a rolled section,

$l_e$  = distance between prying force and bolt centreline and is the minimum of either the end distance or the value given by:

$$l_e = 1.1t \sqrt{\frac{\beta f_o}{f_y}}$$

where

$\beta$  = 2 for non pre-tensioned bolt and 1 for pre-tensioned bolt,

$\eta$  = 1.5,

$b_e$  = effective width of flange per pair of bolts,

$f_o$  = proof stress in consistent units, and

$t$  = thickness of the end plate.

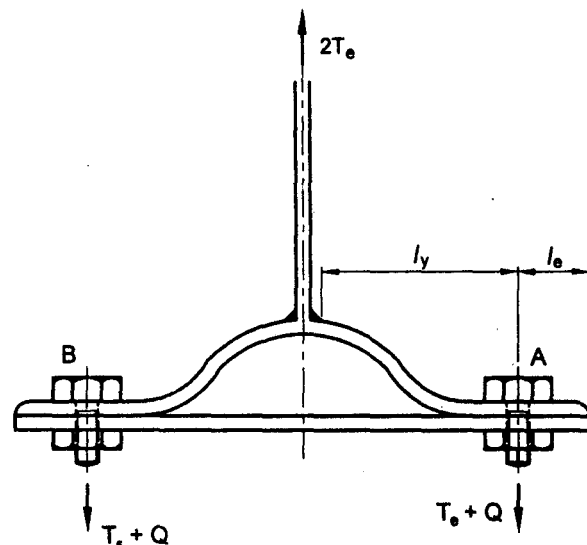


FIG. 16 COMBINED PRYING FORCE AND TENSION



**10.5 Welds and Welding**

**10.5.1 General**

Requirements of welds and welding shall conform to IS 816 and IS 9595, as appropriate.

**10.5.1.1 End returns**

Fillet welds terminating at the ends or sides of parts should be returned continuously around the corners for a distance of not less than twice the size of the weld, unless it is impractical to do so. This is particularly important on the tension end of parts carrying bending loads.

**10.5.1.2 Lap joint**

In the case of lap joints, the minimum lap should not be less than four times the thickness of the thinner part joined or 40 mm, whichever is more. Single end fillet should be used only when lapped parts are restrained from openings. When end of an element is connected only by parallel longitudinal fillet welds, the length of the weld along either edge should not be less than the transverse spacing between longitudinal welds.

**10.5.1.3** A single fillet weld should not be subjected to moment about the longitudinal axis of the weld.

**10.5.2 Size of Weld**

**10.5.2.1** The size of normal fillets shall be taken as the minimum weld leg size. For deep penetration welds, where the depth of penetration beyond the root run is a minimum of 2.4 mm, the size of the fillet should be taken as the minimum leg size plus 2.4 mm.

**10.5.2.2** For fillet welds made by semi-automatic or automatic processes, where the depth of penetration is considerably in excess of 2.4 mm, the size shall be taken considering actual depth of penetration subject to agreement between the purchaser and the contractor.

**10.5.2.3** The size of fillet welds shall not be less than 3 mm. The minimum size of the first run or of a single run fillet weld shall be as given in Table 21, to avoid the risk of cracking in the absence of preheating.

**10.5.2.4** The size of butt weld shall be specified by the effective throat thickness.

**10.5.3 Effective Throat Thickness**

**10.5.3.1** The effective throat thickness of a fillet weld

shall not be less than 3 mm and shall generally not exceed  $0.7t$ , or  $1.0t$  under special circumstances, where  $t$  is the thickness of the thinner plate of elements being welded.

**Table 21 Minimum Size of First Run or of a Single Run Fillet Weld**  
(Clause 10.5.2.3)

SI No.	Thickness of Thicker Part mm		Minimum Size mm
	Over	Up to and Including	
(1)	(2)	(3)	(4)
i)	–	10	3
ii)	10	20	5
iii)	20	32	6
iv)	32	50	8 of first run 10 for minimum size of weld

NOTES

1 When the minimum size of the fillet weld given in the table is greater than the thickness of the thinner part, the minimum size of the weld should be equal to the thickness of the thinner part. The thicker part shall be adequately preheated to prevent cracking of the weld.

2 Where the thicker part is more than 50 mm thick, special precautions like pre-heating should be taken.

**10.5.3.2** For the purpose of stress calculation in fillet welds joining faces inclined to each other, the effective throat thickness shall be taken as  $K$  times the fillet size, where  $K$  is a constant, depending upon the angle between fusion faces, as given in Table 22.

**10.5.3.3** The effective throat thickness of a complete penetration butt weld shall be taken as the thickness of the thinner part joined, and that of an incomplete penetration butt weld shall be taken as the minimum thickness of the weld metal common to the parts joined, excluding reinforcements.

**10.5.4 Effective Length or Area of Weld**

**10.5.4.1** The effective length of fillet weld shall be taken as only that length which is of the specified size and required throat thickness. In practice the actual length of weld is made of the effective length shown in drawing plus two times the weld size, but not less than four times the size of the weld.

**10.5.4.2** The effective length of butt weld shall be taken as the length of the continuous full size weld, but not less than four times the size of the weld.

**Table 22 Values of  $K$  for Different Angles Between Fusion Faces**  
(Clause 10.5.3.2)

Angle Between Fusion Faces	60°–90°	91°–100°	101°–106°	107°–113°	114°–120°
Constant, $K$	0.70	0.65	0.60	0.55	0.50

**10.5.4.3** The effective area of a plug weld shall be considered as the nominal area of the hole in the plane of the faying surface. These welds shall not be designed to carry stresses.

**10.5.4.4** If the maximum length  $l_j$  of the side welds transferring shear along its length exceeds 150 times the throat size of the weld,  $t_t$ , the reduction in weld strength as per the long joint (see 10.5.7.3) should be considered. For flange to web connection, where the welds are loaded for the full length, the above limitation would not apply.

### 10.5.5 Intermittent Welds

**10.5.5.1** Unless otherwise specified, the intermittent fillet welding shall have an effective length of not less than four times the weld size, with a minimum of 40 mm.

**10.5.5.2** The clear spacing between the effective lengths of intermittent fillet weld shall not exceed 12 and 16 times the thickness of thinner plate joined, for compression and tension joint respectively, and in no case be more than 200 mm.

**10.5.5.3** Unless otherwise specified, the intermittent butt weld shall have an effective length of not less than four times the weld size and the longitudinal space between the effective length of welds shall not be more than 16 times the thickness of the thinner part joined. The intermittent welds shall not be used in positions subject to dynamic, repetitive and alternating stresses.

### 10.5.6 Weld Types and Quality

For the purpose of this code, weld shall be fillet, butt, slot or plug or compound welds. Welding electrodes shall conform to IS 814.

### 10.5.7 Design Stresses in Welds

#### 10.5.7.1 Shop welds

##### 10.5.7.1.1 Fillet welds

Design strength of a fillet weld,  $f_{wd}$  shall be based on its throat area and shall be given by:

$$f_{wd} = f_{wn} / \gamma_{mw}$$

where

$$f_{wn} = f_u / \sqrt{3},$$

$f_u$  = smaller of the ultimate stress of the weld or of the parent metal, and

$\gamma_{mw}$  = partial safety factor (see Table 5).

##### 10.5.7.1.2 Butt welds

Butt welds shall be treated as parent metal with a thickness equal to the throat thickness, and the stresses shall not exceed those permitted in the parent metal.

#### 10.5.7.1.3 Slot or plug welds

The design shear stress on slot or plug welds shall be as per 10.5.7.1.1.

#### 10.5.7.2 Site welds

The design strength in shear and tension for site welds made during erection of structural members shall be calculated according to 10.5.7.1 but using a partial safety factor  $\gamma_{mw}$  of 1.5.

#### 10.5.7.3 Long joints

When the length of the welded joint,  $l_j$  of a splice or end connection in a compression or tension element is greater than 150  $t_t$ , the design capacity of weld (see 10.5.7.1.1),  $f_{wd}$  shall be reduced by the factor

$$\beta_{lw} = 1.2 - \frac{0.2l_j}{150t_t} \leq 1.0$$

where

$l_j$  = length of the joint in the direction of the force transfer, and

$t_t$  = throat size of the weld.

### 10.5.8 Fillet Weld Applied to the Edge of a Plate or Section

**10.5.8.1** Where a fillet weld is applied to the square edge of a part, the specified size of the weld should generally be at least 1.5 mm less than the edge thickness in order to avoid washing down of the exposed arris (see Fig. 17A).

**10.5.8.2** Where the fillet weld is applied to the rounded toe of a rolled section, the specified size of the weld should generally not exceed 3/4 of the thickness of the section at the toe (see Fig. 17B).

**10.5.8.3** Where the size specified for a fillet weld is such that the parent metal will not project beyond the weld, no melting of the outer cover or covers shall be allowed to occur to such an extent as to reduce the throat thickness (see Fig. 18).

**10.5.8.4** When fillet welds are applied to the edges of a plate or section in members subject to dynamic loading, the fillet weld shall be of full size with its leg length equal to the thickness of the plate or section, with the limitations specified in 10.5.8.3.

**10.5.8.5** End fillet weld, normal to the direction of force shall be of unequal size with a throat thickness not less than 0.5 $t$ , where  $t$  is the thickness of the part, as shown in Fig. 19. The difference in thickness of the welds shall be negotiated at a uniform slope.

### 10.5.9 Stresses Due to Individual Forces

When subjected to either compressive or tensile or

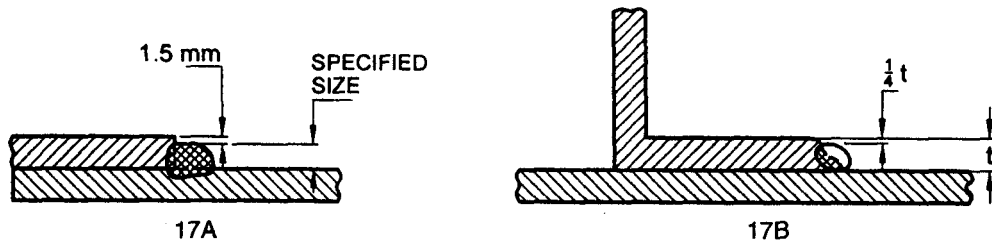


FIG. 17 FILLET WELDS ON SQUARE EDGE OF PLATE OR ROUND TOE OF ROLLED SECTION

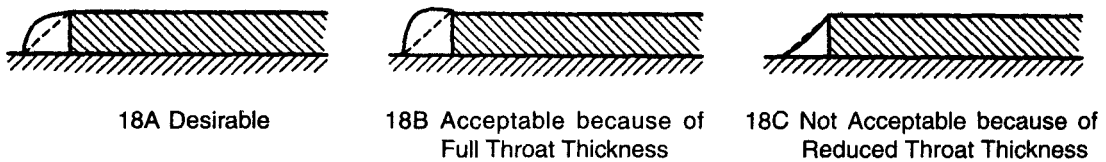


FIG. 18 FULL SIZE FILLET WELD APPLIED TO THE EDGE OF A PLATE OR SECTION

shear force alone, the stress in the weld is given by:

$$f_a \text{ or } q = \frac{P}{t_e l_w}$$

where

- $f_a$  = calculated normal stress due to axial force, in  $N/mm^2$ ;
- $q$  = shear stress, in  $N/mm^2$ ;
- $P$  = force transmitted (axial force  $N$  or the shear force  $Q$ );
- $t_e$  = effective throat thickness of weld, in mm; and
- $l_w$  = effective length of weld, in mm.

**10.5.10 Combination of Stresses**

**10.5.10.1 Fillet welds**

**10.5.10.1.1** When subjected to a combination of normal and shear stress, the equivalent stress  $f_e$  shall satisfy the following:

$$f_e = \sqrt{f_a^2 + 3q^2} \leq \frac{f_u}{\sqrt{3}\gamma_{mw}}$$

where

- $f_a$  = normal stresses, compression or tension, due to axial force or bending moment (see 10.5.9), and
- $q$  = shear stress due to shear force or tension (see 10.5.9).

**10.5.10.1.2** Check for the combination of stresses need

not be done for:

- a) side fillet welds joining cover plates and flange plates, and
- b) fillet welds where sum of normal and shear stresses does not exceed  $f_{wd}$  (see 10.5.7.1.1).

**10.5.10.2 Butt welds**

**10.5.10.2.1** Check for the combination of stresses in butt welds need not be carried out provided that:

- a) butt welds are axially loaded, and
- b) in single and double bevel welds the sum of normal and shear stresses does not exceed the design normal stress, and the shear stress does not exceed 50 percent of the design shear stress.

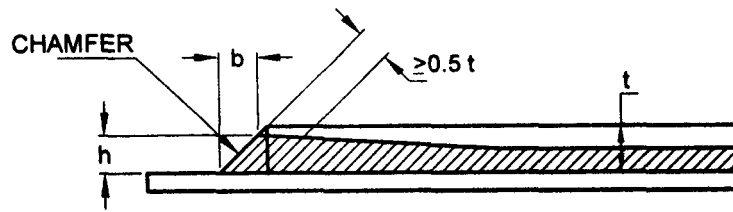
**10.5.10.2.2 Combined bearing, bending and shear**

Where bearing stress,  $f_{br}$  is combined with bending (tensile or compressive),  $f_b$  and shear stresses,  $q$  under the most unfavorable conditions of loading in butt welds, the equivalent stress,  $f_e$  as obtained from the following formula, shall not exceed the values allowed for the parent metal:

$$f_e = \sqrt{f_b^2 + f_{br}^2 + f_b f_{br} + 3q^2}$$

where

- $f_e$  = equivalent stress;
- $f_b$  = calculated stress due to bending, in  $N/mm^2$ ;
- $f_{br}$  = calculated stress due to bearing, in  $N/mm^2$ ; and
- $q$  = shear stress, in  $N/mm^2$ .



$h:b = 1:2$  or Flatter

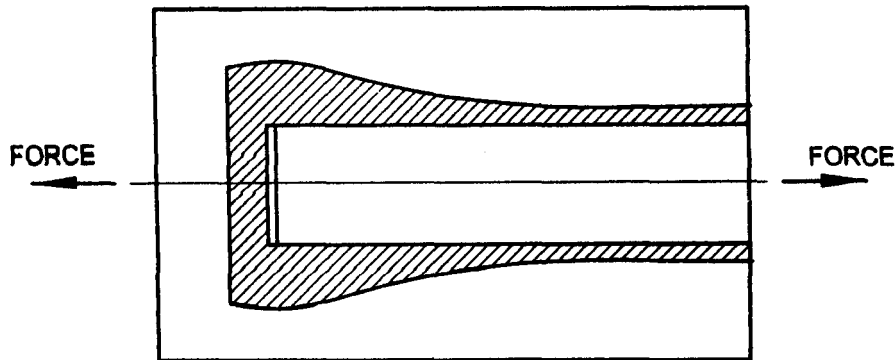


FIG. 19 END FILLET WELD NORMAL TO DIRECTION OR FORCE

**10.5.11** Where a packing is welded between two members and is less than 6 mm thick, or is too thin to allow provision of adequate welds or to prevent buckling, the packing shall be trimmed flush with the edges of the element subject to the design action and the size of the welds along the edges shall be increased over the required size by an amount equal to the thickness of the packing. Otherwise, the packing shall extend beyond the edges and shall be fillet welded to the pieces between which it is fitted.

### 10.6 Design of Connections

Each element in a connection shall be designed so that the structure is capable of resisting the design actions. Connections and adjacent regions of the members shall be designed by distributing the design action effects such that the following requirements are satisfied:

- Design action effects distributed to various elements shall be in equilibrium with the design action effects on the connection,
- Required deformations in the elements of the connections are within their deformations capacities,
- All elements in the connections and the adjacent areas of members shall be capable of resisting the design action effects acting on them, and

- Connection elements shall remain stable under the design action effects and deformations.

**10.6.1** Connections can be classified as rigid, semi-rigid and flexible for the purpose of analysis and design as per the recommendation in Annex F. Connections with sufficient rotational stiffness may be considered as rigid. Examples of rigid connections include flush end-plate connection and extended end-plate connections. Connections with negligible rotational stiffness may be considered as flexible (pinned). Examples of flexible connections include single and double web angle connections and header plate connections. Where a connection cannot be classified as either rigid or flexible, it shall be assumed to be semi-rigid. Examples of semi-rigid connections include top and seat angle connection and top and seat angle with single/double web angles.

**10.6.2** Design shall be on the basis of any rational method supported by experimental evidence. Residual stresses due to installation of bolts or welding normally need not be considered in statically loaded structures. Connections in cyclically loaded structures shall be designed considering fatigue as given in Section 13. For earthquake load combinations, the connections shall be designed to withstand the calculated design action effects and exhibit required ductility as specified in Section 12.

**10.6.3** Beam and column splice shall be designed in accordance with the recommendation given in F-2 and F-3.

### 10.7 Minimum Design Action on Connection

Connections carrying design action effects, except for lacing connections, connections of sag rods, purlins and girts, shall be designed to transmit the greater of:

- a) the design action in the member; and
- b) the minimum design action effects expressed either as the value or the factor times the member design capacity for the minimum size of member required by the strength limit state, specified as follows:
  - 1) *Connections in rigid construction* — a bending moment of at least 0.5 times the member design moment capacity
  - 2) *Connections to beam in simple construction* — a shear force of at least 0.15 times the member design shear capacity or 40 kN, whichever is lesser
  - 3) *Connections at the ends of tensile or compression member* — a force of at least 0.3 times the member design capacity
  - 4) *Splices in members subjected to axial tension* — a force of at least 0.3 times the member design capacity in tension
  - 5) *Splices in members subjected to axial compression* — for ends prepared for full contact in accordance with 17.7.1, it shall be permissible to carry compressive actions by bearing on contact surfaces. When members are prepared for full contact to bear at splices, there shall be sufficient fasteners to hold all parts securely in place. The fasteners shall be sufficient to transmit a force of at least 0.15 times the member design capacity in axial compression.

When members are not prepared for full contact, the splice material and its fasteners shall be arranged to hold all parts in line and shall be designed to transmit a force of at least 0.3 times the member design capacity in axial compression.

In addition, splices located between points of effective lateral support shall be designed for the design axial force,  $P_d$  plus a design bending moment, not less than the design bending moment  $M_d = (P_d l_s)/1\ 000$

where,  $l_s$  is the distance between points of effective lateral support.

- 6) *Splices in flexural members* — a bending moment of 0.3 times the member design capacity in bending. This provision shall not apply to splices designed to transmit shear force only.

A splice subjected to a shear force only shall be designed to transmit the design shear force together with any bending moment resulting from the eccentricity of the force with respect to the centroid of the group.

- 7) *Splices in members subject to combined actions* — a splice in a member subject to a combination of design axial tension or design axial compression and design bending moment shall satisfy requirements in (4), (5) and (6) above, simultaneously.

For earthquake load combinations, the design action effects specified in this section may need to be increased to meet the required behaviour of the steel frame and shall comply with Section 12.

### 10.8 Intersections

Members or components meeting at a joint shall be arranged to transfer the design actions between the parts, wherever practicable, with their centroidal axes meeting at a point. Where there is eccentricity at joints, the members and components shall be designed for the design bending moments which result due to eccentricity.

The disposition of fillet welds to balance the design actions about the centroidal axis or axes for end connections of single angle, double angle and similar type members is not required for statically loaded members but is required for members, connection components subject to fatigue loading.

Eccentricity between the centroidal axes of angle members and the gauge lines for their bolted end connections may be neglected in statically loaded members, but shall be considered in members and connection components subject to fatigue loading.

### 10.9 Choice of Fasteners

Where slip in the serviceability limit state is to be avoided in a connection, high-strength bolts in a friction-type joint, fitted bolts or welds shall be used.

Where a joint is subjected to impact or vibration, either high strength bolts in a friction type joint or ordinary bolts with locking devices or welds shall be used.

### 10.10 Connection Components

Connection components (cleats, gusset plates, brackets

and the like) other than connectors, shall have their capacities assessed using the provisions of Sections 5, 6, 7, 8 and 9, as applicable.

## 10.11 Analysis of a Bolt/Weld Group

### 10.11.1 Bolt/Weld Group Subject to In-plane Loading

#### 10.11.1.1 General method of analysis

The design force in a bolt/weld or design force per unit length in a bolt/weld group subject to in-plane loading shall be determined in accordance with the following:

- a) The connection plates shall be considered to be rigid and to rotate relative to each other about a point known as the instantaneous centre of rotation of the group.
- b) In the case of a group subject to a pure couple only, the instantaneous centre of rotation coincides with the group centroid. In the case of in-plane shear force applied at the group centroid, the instantaneous centre of the rotation is at infinity and the design force is uniformly distributed throughout the group. In all other cases, either the results of independent analyses for a pure couple alone and for an in-plane shear force applied at the group centroid shall be superposed, or a recognized method of analysis shall be used.
- c) The design force in a bolt or design force per unit length at any point in the group shall be assumed to act at right angles to the radius from that point to the instantaneous centre, and shall be taken as proportional to that radius.

### 10.11.2 Bolt/Weld Group Subject to Out-of-Plane Loading

#### 10.11.2.1 General method of analysis

The design force of a bolt in bolt group or design force per unit length in the fillet weld group subject to out-of-plane loading shall be determined in accordance with the following:

- a) Design force in the bolts or per unit length in the fillet weld group resulting from any shear force or axial force shall be considered to be equally shared by all bolts in the group or uniformly distributed over the length of the fillet weld group.
- b) Design force resulting from a design bending moment shall be considered to vary linearly with the distance from the relevant centroidal axes:
  - 1) In bearing type of bolt group plates in the compression side of the neutral axis

and only bolts in the tension side of the neutral axis may be considered for calculating the neutral axis and second moment of area.

- 2) In the friction grip bolt group only the bolts shall be considered in the calculation of neutral axis and second moment of area.
- 3) The fillet weld group shall be considered in isolation from the connected element; for the calculation of centroid and second moment of the weld length.

#### 10.11.2.2 Alternative analysis

The design force per unit length in a fillet weld/bolt group may alternatively be determined by considering the fillet weld group as an extension of the connected member and distributing the design forces among the welds of the fillet weld group so as to satisfy equilibrium between the fillet weld group and the elements of the connected member.

### 10.11.3 Bolt/Weld Group Subject to In-plane and Out-of-Plane Loading

#### 10.11.3.1 General method of analysis

The design force in a bolt or per unit length of the weld shall be determined by the superposition of analysis for in-plane and out-of-plane cases discussed in 10.11.1 and 10.11.2.

#### 10.11.3.2 Alternative analysis

The design force in a bolt or per unit length in the fillet weld group may alternatively be determined by considering the fillet weld group as an extension of the connected member and proportioning the design force per bolt or unit length in the weld group to satisfy equilibrium between the bolt/weld group and the elements of the connected member.

Force calculated in the most stressed bolt or highest force per unit length of the weld shall satisfy the strength requirements of 10.3, 10.4 or 10.5, as appropriate.

## 10.12 Lug Angles

10.12.1 Lug angles connecting outstanding leg of a channel-shaped member shall, as far as possible, be disposed symmetrically with respect to the section of the member.

10.12.2 In the case of angle members, the lug angles and their connections to the gusset or other supporting member shall be capable of developing a strength not less than 20 percent in excess of the force in the outstanding leg of the member, and the attachment of the lug angle to the main angle shall be capable of

developing a strength not less than 40 percent in excess of the force in the outstanding leg of the angle.

**10.12.3** In the case of channel members and the like, the lug angles and their connection to the gusset or other supporting member shall be capable of developing a strength of not less than 10 percent in excess of the force not accounted for by the direct connection of the member, and the attachment of the lug angles to the member shall be capable of developing 20 percent in excess of that force.

**10.12.4** In no case shall fewer than two bolts, rivets or equivalent welds be used for attaching the lug angle to the gusset or other supporting member.

**10.12.5** The effective connection of the lug angle shall, as far as possible terminate at the end of the member connected, and the fastening of the lug angle to the main member shall preferably start in advance of the direct connection of the member to the gusset or other supporting member.

**10.12.6** Where lug angles are used to connect an angle member, the whole area of the member shall be taken as effective not withstanding the requirements of Section 6 of this standard.

## SECTION 11 WORKING STRESS DESIGN

### 11.1 General

**11.1.1** General design requirements of Section 3 shall apply in this section.

**11.1.2** Methods of structural analysis of Section 4 shall also apply to this section. The elastic analysis method shall be used in the working stress design.

**11.1.3** The working stress shall be calculated applying respective partial load factor for service load/working load.

**11.1.4** In load combinations involving wind or seismic loads, the permissible stresses in steel structural members may be increased by 33 percent. For anchor bolts and construction loads this increase shall be limited to 25 percent. Such an increase in allowable stresses should not be considered if the wind or seismic load is the major load in the load combination (such as acting along with dead load alone).

### 11.2 Tension Members

#### 11.2.1 Actual Tensile Stress

The actual tensile stress,  $f_t$  on the gross area of cross-section,  $A_g$  of plates, angles and other tension members shall be less than or equal to the smaller value of permissible tensile stresses,  $f_{at}$ , as given below:

Actual tensile stress,  $f_t = T_s / A_g$

The permissible stress,  $f_{at}$  is smallest of the values as obtained below:

- a) As governed by yielding of gross section

$$f_{at} = 0.6 f_y$$

- b) As governed by rupture of net section

- 1) Plates under tension

$$f_{at} = 0.69 T_{dn} / A_g$$

- 2) Angles under tension

$$f_{at} = 0.69 T_{dn} / A_g$$

- c) As governed by block shear

$$f_{at} = 0.69 T_{db} / A_g$$

where

$T_s$  = actual tension under working (service) load,

$A_g$  = gross area,

$T_{dn}$  = design strength in tension of respective plate/angle calculated in accordance with 6.3, and

$T_{db}$  = design block shear strength in tension of respective plate/angle calculated in accordance with 6.4.

### 11.3 Compression Members

#### 11.3.1 Actual Compressive Stress

The actual compressive stress,  $f_c$  at working (service) load,  $P_s$  of a compression member shall be less than or equal to the permissible compressive stress,  $f_{ac}$  as given below:

Actual compressive stress,  $f_c = P_s / A_e$

The permissible compressive stress,  $f_{ac} = 0.60 f_{cd}$

where

$A_e$  = effective sectional area as defined in 7.3.2, and

$f_{cd}$  = design compressive stress as defined in 7.1.2.1 (for angles see 7.5.1.2).

#### 11.3.2 Design Details

Design of the compression members shall conform to 7.3.

#### 11.3.3 Column Bases

The provisions of 7.4 shall be followed for the design of column bases, except that the thickness of a simple column base,  $t_s$  shall be calculated as:

$$t_s = \sqrt{3 w (a^2 - 0.3 b^2) / f_{bs}}$$

where

$w$  = uniform pressure from below on the slab base due to axial compression;

$a, b$  = larger and smaller projection of the slab base beyond the rectangle circumscribing the column, respectively; and

$f_{bs}$  = permissible bending stress in column base equal to  $0.75 f_y$ .

### 11.3.4 Angle Struts

Provisions of 7.5 shall be used for design of angle struts, except that the limiting actual stresses shall be calculated in accordance with 11.3.1.

### 11.3.5 Laced and Battened Columns

The laced and battened columns shall be designed in accordance with 7.6 and 7.7, except that the actual stresses shall be less than the permissible stresses given in 11.3.1.

## 11.4 Members Subjected to Bending

### 11.4.1 Bending Stresses

The actual bending tensile and compressive stresses,  $f_{bt}, f_{bc}$  at working (service) load moment,  $M_s$  of a bending member shall be less than or equal to the permissible bending stresses,  $f_{abt}, f_{abc}$  respectively, as given herein. The actual bending stresses shall be calculated as:

$$f_{bc} = M_s / Z_{ec} \quad \text{and} \quad f_{bt} = M_s / Z_{et}$$

The permissible bending stresses,  $f_{abc}$  or  $f_{abt}$  shall be the smaller of the values obtained from the following:

a) *Laterally supported beams and beams bending about the minor axis:*

1) *Plastic and compact sections*

$$f_{abc} \text{ or } f_{abt} = 0.66 f_y$$

2) *Semi-compact sections*

$$f_{abc} \text{ or } f_{abt} = 0.60 f_y$$

b) *Laterally unsupported beams subjected to major axis bending:*

$$f_{abc} = 0.60 M_d / Z_{ec}$$

$$f_{abt} = 0.60 M_d / Z_{et}$$

c) *Plates and solid rectangles bending about minor axis:*

$$f_{abc} = f_{abt} = 0.75 f_y$$

where

$Z_{ec}, Z_{et}$  = elastic section modulus for the cross section with respect to extreme compression and tension fibres, respectively;

$f_y$  = yield stress of the sect; and

$M_d$  = design bending strength of a laterally unsupported beam bent about major axis, calculated in accordance with 8.2.2.

### 11.4.2 Shear Stress in Bending Members

The actual shear stress,  $\tau_b$  at working load,  $V_s$  of a bending member shall be less than or equal to the permissible shear stress,  $\tau_{ab}$  given below:

$$\text{Actual shear stress, } \tau_b = V_s / A_v$$

The permissible shear stress is given by:

a) When subjected pure shear:

$$\tau_{ab} = 0.40 f_y$$

b) When subject to shear buckling (see 8.4.2.1):

$$\tau_{ab} = 0.70 V_n / A_v$$

where

$V_n$  = design shear strength as given in 8.4.2.2 (a), and

$A_v$  = shear area of the cross-section as given in 8.4.1.

### 11.4.3 Plate Girder

Provisions of 8.3, 8.4, 8.5, 8.6 and 8.7 shall apply, for the design of plate girder, except that the allowable stresses shall conform to 11.4.1 and 11.4.2.

### 11.4.4 Box Girder

In design of box girder the provisions of 8.8 shall apply, except that the allowable bending stresses shall conform to 11.4.1.

## 11.5 Combined Stresses

### 11.5.1 Combined Bending and Shear

Reduction in allowable moment need not be considered under combined bending and shear.

### 11.5.2 Combined Bending and Axial Force

Members subjected to combined axial compression and bending shall be so proportioned to satisfy the following requirements:

a) *Member stability requirement:*

$$\frac{f_c}{f_{acy}} + 0.6 K_y \frac{C_{my} f_{bcy}}{f_{abcy}} + K_{LT} \frac{f_{bcz}}{f_{abcz}} \leq 1.0;$$

$$\frac{f_c}{f_{acz}} + 0.6 K_y \frac{C_{my} f_{bcy}}{f_{abcy}} + K_z \frac{C_{mz} f_{bcz}}{f_{abcz}} \leq 1.0$$

where

$C_{my}, C_{mz}$  = equivalent uniform moment factor as per Table 18,

$f_c$  = applied axial compressive stress under service load,

$f_{bcy}, f_{bcz}$  = applied compressive stresses due to bending about the major (y) and minor (z) axis of the member, respectively,



$f_{acy}, f_{acz}$  = allowable axial compressive stress as governed by buckling about minor (y) and major (z) axis, respectively,

$f_{abcy}, f_{abcz}$  = allowable bending compressive stresses due to bending about minor (y) and major (z) axes of the cross-section (see 11.4),

$$K_y = 1 + (\lambda_y - 0.2)n_y \leq 1 + 0.8 n_y,$$

$$K_z = 1 + (\lambda_z - 0.2)n_z \leq 1 + 0.8 n_z,$$

$$1 - \frac{0.1\lambda_{LT} n_y}{(C_{mLT} - 0.25)} \geq 1$$

$$K_{LT} = \frac{0.1 n_y}{(C_{mLT} - 0.25)},$$

where

$n_y, n_z$  = ratio of actual applied axial stress to the allowable axial stress for buckling about the y and z axis, respectively;

$C_{mLT}$  = equivalent uniform moment factor; and

$\lambda_{LT}$  = non-dimensional slenderness ratio (see 8.2.2).

#### b) Member strength requirement

At a support the values  $f_{abcy}$  and  $f_{abcz}$  shall be calculated using laterally supported member and shall satisfy:

$$\frac{f_c}{0.6 f_y} + \frac{f_{bcy}}{f_{abcy}} + \frac{f_{bcz}}{f_{abcz}} \leq 1.0$$

#### 11.5.3 Combined Bending and Axial Tension

Members subjected to both axial tension and bending shall be proportioned so that the following condition is satisfied:

$$\frac{f_t}{f_{at}} + \frac{f_{bty}}{f_{abty}} + \frac{f_{btz}}{f_{abtz}} \leq 1.0$$

where

$f_{abty}, f_{abtz}$  = permissible tensile stresses under bending about minor (y) and major (z) axis when bending alone is acting, as given in 11.4.1.

#### 11.5.4 Combined Bearing, Bending and Shear Stresses

Where a bearing stress is combined with tensile or compressive stress, bending and shear stresses under the most unfavourable conditions of loading, the equivalent stress,  $f_e$  obtained from the following

formula, shall not exceed  $0.9f_y$

$$f_e = \sqrt{f_b^2 + f_p^2 + f_b^2 f_p^2 + 3\tau_b^2}$$

where

$\tau$  = actual shear stress,

$f_t$  = actual tensile stress,

$f_y$  = yield stress, and

$f_p$  = actual bearing stress.

The value of permissible bending stresses  $f_{bcy}$  and  $f_{bcz}$  to be used in the above formula shall each be lesser of the values of the maximum allowable stresses  $f_{abc}$  and  $f_{abt}$  in bending about appropriate axis.

### 11.6 Connections

11.6.1 All design provisions of Section 10, except for the actual and permissible stress calculations, shall apply.

#### 11.6.2 Actual Stresses in Fasteners

11.6.2.1 Actual stress in bolt in shear,  $f_{sb}$  should be less than or equal to permissible stress of the bolt,  $f_{asb}$  as given below:

The actual stress in bolt in shear,  $f_{sb} = V_{sb}/A_{sb}$

The permissible stress in bolt in shear,  $f_{asb} = 0.60 V_{nsb}/A_{sb}$

where

$V_{sb}$  = actual shear force under working (service) load,

$V_{nsb}$  = nominal shear capacity of the bolt as given in 10.3.3, and

$A_{sb}$  = nominal plain shank area of the bolt.

11.6.2.2 Actual stress of bolt in bearing on any plate,  $f_{pb}$  should be less than or equal to the permissible bearing stress of the bolt/plate,  $f_{apb}$  as given below:

Actual stress of bolt in bearing on any plate,

$$f_{pb} = V_{sb} / A_{pb}$$

The permissible bearing stress of the bolt/plate,

$$f_{apb} = 0.60 V_{npb} / A_{pb}$$

where

$V_{npb}$  = nominal bearing capacity of a bolt on any plate as given in 10.3.4, and

$A_{pb}$  = nominal bearing area of the bolt on any plate.

11.6.2.3 Actual tensile stress of the bolt,  $f_{tb}$  should be less than or equal to permissible tensile stress of the bolt,  $f_{atb}$  as given below:

Actual tensile stress of the bolt,  $f_{tb} = T_s / A_{sb}$

The permissible tensile stress of the bolt,

$$f_{atb} = 0.60 T_{nb} / A_{sb}$$

where

$T_s$  = tension in bolt under working (service) load,

$T_{nb}$  = design tensile capacity of a bolt as given in 10.3.5, and

$A_{sb}$  = nominal plain shank area of the bolt.

**11.6.2.4** Actual compressive or tensile or shear stress of a weld,  $f_w$  should be less than or equal to permissible stress of the weld,  $f_{aw}$  as given below:

The permissible stress of the weld,  $f_{aw} = 0.6 f_{wn}$

where

$f_{wn}$  = nominal shear capacity of the weld as calculated in 10.5.7.1.1.

**11.6.2.5** If the bolt is subjected to combined shear and tension, the actual shear and axial stresses calculated in accordance with 11.6.2.1 and 11.6.2.3 do not exceed the respective permissible stresses  $f_{asb}$  and  $f_{atb}$  then the expression given below should satisfy:

$$\left[ \frac{f_{sb}}{f_{asb}} \right]^2 + \left[ \frac{f_{tb}}{f_{atb}} \right]^2 \leq 1.0$$

where

$f_{sb}, f_{tb}$  = actual shear and tensile stresses respectively, and

$f_{asb}, f_{atb}$  = permissible shear and tensile stresses respectively.

### 11.6.3 Stresses in Welds

**11.6.3.1** Actual stresses in the throat area of fillet welds shall be less than or equal to permissible stresses,  $f_{aw}$  as given below:

$$f_{aw} = 0.4 f_y$$

**11.6.3.2** Actual stresses in the butt welds shall be less than the permissible stress as governed by the parent metal welded together.

## SECTION 12 DESIGN AND DETAILING FOR EARTHQUAKE LOADS

### 12.1 General

Steel frames shall be so designed and detailed as to give them adequate strength, stability and ductility to resist severe earthquakes in all zones classified in IS 1893 (Part 1) without collapse. Frames, which form a part of the gravity load resisting system but are not intended to resist the lateral earthquake loads, need not satisfy the requirements of this section, provided they can accommodate the resulting deformation

without premature failure.

### 12.2 Load and Load Combinations

**12.2.1** Earthquake loads shall be calculated as per IS 1893 (Part 1), except that the reduction factors recommended in 12.3 may be used.

**12.2.2** In the limit state design of frames resisting earthquake loads, the load combinations shall conform to Table 4.

**12.2.3** In addition the following load combination shall be considered as required in 12.5.1.1, 12.7.3.1, 12.11.2.2 and 12.11.3.4:

- a) 1.2 Dead Load (DL) + 0.5 Live Load (LL) ± 2.5 Earthquake Load (EL); and
- b) 0.9 Dead Load (DL) ± 2.5 Earthquake Load (EL).

### 12.3 Response Reduction Factor

For structures designed and detailed as per the provision of this section, the response reduction factors specified in Table 23 may be used in conjunction with the provision in IS 1893 for calculating the design earthquake forces.

**Table 23 Response Reduction Factor (R) for Building System**

Sl No.	Lateral Load Resisting System	R
(1)	(2)	(3)
i)	<i>Braced Frame Systems:</i>	
a)	Ordinary Concentrically Braced Frames (OCBF)	4
b)	Special Concentrically Braced Frame (SCBF)	4.5
c)	Eccentrically Braced Frame (EBF)	5
ii)	<i>Moment Frame System:</i>	
a)	Ordinary Moment Frame (OMF)	4
b)	Special Moment Frame (SMF)	5

### 12.4 Connections, Joints and Fasteners

**12.4.1** All bolts used in frames designed to resist earthquake loads shall be fully tensioned high strength friction grip (HSFG) bolts or turned and fitted bolts.

**12.4.2** All welds used in frames designed to resist earthquake loads shall be complete penetration butt welds, except in column splices, which shall conform to 12.5.2.

**12.4.3** Bolted joints shall be designed not to share load in combination with welds on the same faying surface.

### 12.5 Columns

#### 12.5.1 Column Strength

When  $P_f/P_d$  is greater than 0.4, the requirements in 12.5.1.1 and 12.5.1.2 shall be met.

Where

$P_r$  = required compressive strength of the member, and

$P_d$  = design stress in axial compression as obtained from 7.1.2.

**12.5.1.1** The required axial compressive and axial tensile strength in the absence of applied moment, shall be determined from the load combination in 12.2.3.

**12.5.1.2** The required strength determined in 12.5.1.1 need not exceed either of the maximum load transferred to the column considering 1.2 times the nominal strength of the connecting beam or brace element, or the resistance of the foundation to uplift.

### 12.5.2 Column Splice

**12.5.2.1** A partial-joint penetration groove weld may be provided in column splice, such that the design strength of the joints shall be at least equal to 200 percent of the required strength.

**12.5.2.2** The minimum required strength for each flange splice shall be 1.2 times  $f_y A_f$  as showing Fig. 20, where  $A_f$  is the area of each flange in the smaller connected column.

### 12.6 Storey Drift

The storey drift limits shall conform to IS 1893. The deformation compatibility of members not designed to resist seismic lateral load shall also conform to IS 1893 (Part 1).

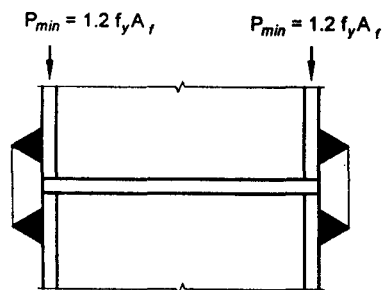


FIG. 20 PARTIAL PENETRATION GROOVE WELD IN COLUMN SPLICE

### 12.7 Ordinary Concentrically Braced Frames (OCBF)

**12.7.1** Ordinary concentrically braced frames (OCBF) should be shown to withstand inelastic deformation corresponding to a joint rotation of at least 0.02 radians without degradation in strength and stiffness below the full yield value. Ordinary concentrically braced frames meeting the requirements of this section shall be deemed to satisfy the required inelastic deformation.

**12.7.1.1** Ordinary concentrically braced frames shall not be used in seismic zones IV and V and for buildings

with importance factor greater than unity ( $I > 1.0$ ) in seismic zone III.

**12.7.1.2** The provision in this section apply for diagonal and X-bracing only. Specialist literature may be consulted for V and inverted V-type bracing. K-bracing shall not be permitted in systems to resist earthquake.

### 12.7.2 Bracing Members

**12.7.2.1** The slenderness of bracing members shall not exceed 120.

**12.7.2.2** The required compressive strength of bracing member shall not exceed 0.8 times  $P_d$ , where  $P_d$  is the design strength in axial compression (see 7.1.2).

**12.7.2.3** Along any line of bracing, braces shall be provided such that for lateral loading in either direction, the tension braces will have to resist between 30 to 70 percent of the total lateral load.

**12.7.2.4** Bracing cross-section can be plastic, compact or semi-compact, but not slender, as defined in 3.7.2.

**12.7.2.5** For all built-up braces, the spacing of tack fasteners shall be such that the unfavourable slenderness ratio of individual element, between such fasteners, shall not exceed 0.4 times the governing slenderness ratio of the brace itself. Bolted connections shall be avoided within the middle one-fourth of the clear brace length (0.25 times the length in the middle).

**12.7.2.6** The bracing members shall be designed so that gross area yielding (see 6.2) and not the net area rupture (see 6.3) would govern the design tensile strength.

### 12.7.3 Bracing Connections

**12.7.3.1** End connections in bracings shall be designed to withstand the minimum of the following:

- A tensile force in the bracing equal to  $1.2 f_y A_g$ ;
- Force in the brace due to load combinations in 12.2.3; and
- Maximum force that can be transferred to the brace by the system.

**12.7.3.2** The connection should be checked for tension rupture and block shear under the load determined in 12.7.3.1.

**12.7.3.3** The connection shall be designed to withstand a moment of 1.2 times the full plastic moment of the braced section about the buckling axis.

**12.7.3.4** Gusset plates shall be checked for buckling out of their plane.

### 12.8 Special Concentrically Braced Frames (SCBF)

**12.8.1** Special concentrically braced frames (SCBF) should be shown to withstand inelastic deformation

corresponding to a joint rotation of at least 0.04 radians without degradation in strength and stiffness below the full yield value. Special concentrically braced frames meeting the requirements of this section shall be deemed to satisfy the required inelastic deformation.

**12.8.1.1** Special concentrically braced frames (SCBF) may be used in any seismic zone [see IS 1893 (Part 1)] and for any building (importance-factor value).

**12.8.1.2** The provision in this section apply for diagonal and X-bracing only. Specialist literature may be consulted for V and inverted V-type bracing. K-bracing shall not be permitted in system to resist earthquake.

### **12.8.2 Bracing Members**

**12.8.2.1** Bracing members shall be made of E250B steel of IS 2062 only.

**12.8.2.2** The slenderness of bracing members shall not exceed 160 (only hangers).

**12.8.2.3** The required compressive strength of bracing member shall not exceed the design strength in axial compression  $P_d$  (see 7.1.2).

**12.8.2.4** Along any line of bracing, braces shall be provided such that for lateral loading in either direction, the tension braces will resist between 30 to 70 percent of the load.

**12.8.2.5** Braced cross-section shall be plastic as defined in 3.7.2.

**12.8.2.6** In built-up braces, the spacing of tack connections shall be such that the slenderness ratio of individual element between such connections shall not exceed 0.4 times the governing slenderness ratio of the brace itself. Bolted connection shall be avoided within the middle one-fourth of the clear brace length (0.25 times the length, in the middle).

**12.8.2.7** The bracing members shall be designed so that gross area yielding (see 6.2) and not the net area rupture (see 6.3) would govern the design tensile strength.

### **12.8.3 Bracing Connections**

**12.8.3.1** Bracing end connections shall be designed to withstand the minimum of the following:

- a) A tensile force in the bracing equal to  $1.1 f_y A_g$ ; and
- b) Maximum force that can be transferred to the brace by the system.

**12.8.3.2** The connection should be checked for tension rupture and block shear under the load determined in 12.8.3.1.

**12.8.3.3** The connection shall be designed to withstand a moment of 1.2 times the full plastic moment of the braced section about the critical buckling axis.

**12.8.3.4** Gusset plates shall be checked for buckling out of their plane.

### **12.8.4 Column**

**12.8.4.1** The column sections used in special concentrically braced frames (SCBF) shall be plastic as defined in 3.7.2.

**12.8.4.2** Splices shall be located within the middle one-third of the column clear height. Splices shall be designed for the forces that can be transferred to it. In addition, splices in columns shall be designed to develop at least the nominal shear strength of the smaller connected member and 50 percent of the nominal flexural strength of the smaller connected section.

### **12.9 Eccentrically Braced Frames (EBF)**

Eccentrically braced frames (EBF) shall be designed in accordance with specialist literature.

### **12.10 Ordinary Moment Frames (OMF)**

**12.10.1** Ordinary moment frames (OMF) should be shown to withstand inelastic deformation corresponding to a joint rotation of 0.02 radians without degradation in strength and stiffness below the full yield value ( $M_p$ ). Ordinary moment frames meeting the requirements of this section shall be deemed to satisfy the required inelastic deformation.

**12.10.1.1** Ordinary moment frames (OMF) shall not be used in seismic zones IV and V and for buildings with importance factor greater than unity ( $I > 1.0$ ) in seismic zone III.

#### **12.10.2 Beam-to-Column Joints and Connections**

Connections are permitted to be rigid or semi-rigid moment connections and should satisfy the criteria in 12.10.2.1 to 12.10.2.5.

**12.10.2.1** Rigid moment connections should be designed to withstand a moment of at least 1.2 times of either the full plastic moment of the connected beam or the maximum moment that can be delivered by the beam to the joint due to the induced weakness at the ends of the beam, whichever is less.

**12.10.2.2** Semi-rigid connections should be designed to withstand either a moment of at least 0.5 times the full plastic moment of the connected beam or the maximum moment that can be delivered by the system, whichever is less. The design moment shall be achieved within a rotation of 0.01 radians. The information given in Annex F may be used for checking.

**12.10.2.3** The stiffness and strength of semi-rigid connections shall be accounted for in the design and the overall stability of the frame shall be ensured.

**12.10.2.4** The rigid and semi-rigid connections should be designed to withstand a shear resulting from the load combination  $1.2DL + 0.5LL$  plus the shear corresponding to the design moment defined in **12.10.2.1** and **12.10.2.2**, respectively.

**12.10.2.5** In rigid fully welded connections, continuity plates (tension stiffener, *see* **8.7**) of thickness equal to or greater than the thickness of the beam flange shall be provided and welded to the column flanges and web.

### 12.11 Special Moment Frames (SMF)

**12.11.1** Special moment frames (SMF) shall be made of E250B steel of IS 2062 and should be shown to withstand inelastic deformation corresponding to a joint rotation of 0.04 radians without degradation in strength and stiffness below the full yield value ( $M_p$ ). Special moment frames meeting the requirements of this section shall be deemed to satisfy the required inelastic deformation.

**12.11.1.1** Special moment frames (SMF) may be used in any seismic zone [*see* IS 1893 (Part 1)] and for any buildings (importance-factor values).

#### 12.11.2 Beam-to-Column Joints and Connections

**12.11.2.1** All beam-to-column connections shall be rigid (*see* Annex F) and designed to withstand a moment of at least 1.2 times the full plastic moment of the connected beam. When a reduced beam section is used, its minimum flexural strength shall be at least equal to 0.8 times the full plastic moment of the unreduced section.

**12.11.2.2** The connection shall be designed to withstand a shear resulting from the load combination  $1.2DL + 0.5LL$  plus the shear resulting from the application of  $1.2M_p$  in the same direction, at each end of the beam (causing double curvature bending). The shear strength need not exceed the required value corresponding to the load combination in **12.2.3**.

**12.11.2.3** In column strong axis connections (beam and column web in the same plane), the panel zone shall be checked for shear buckling in accordance with **8.4.2** at the design shear defined in **12.11.2.2**. Column web doubler plates or diagonal stiffeners may be used to strengthen the web against shear buckling.

**12.11.2.4** The individual thickness of the column webs and doubler plates, shall satisfy the following:

$$t \geq (d_p + b_p) / 90$$

where

- $t$  = thickness of column web or doubler plate,
- $d_p$  = panel-zone depth between continuity plate, and
- $b_p$  = panel-zone width between column flanges.

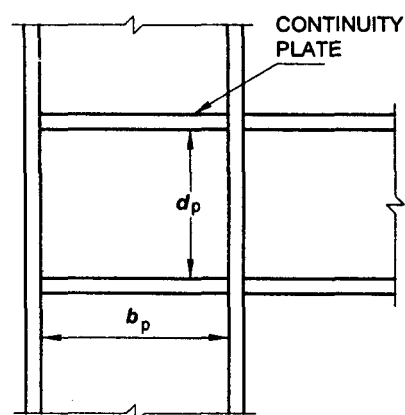


FIG. 21 CONTINUITY PLATES

**12.11.2.5** Continuity plates (tension stiffener) (*see* **8.7**) shall be provided in all strong axis welded connections except in end plate connection.

#### 12.11.3 Beam and Column Limitation

**12.11.3.1** Beam and column sections shall be either plastic or compact as defined in **3.7.2**. At potential plastic hinge locations, they shall necessarily be plastic.

**12.11.3.2** The section selected for beams and columns shall satisfy the following relation:

$$\frac{\sum M_{pc}}{\sum M_{pb}} \geq 1.2$$

where

- $\sum M_{pc}$  = sum of the moment capacity in the column above and below the beam centreline; and
- $\sum M_{pb}$  = sum of the moment capacity in the beams at the intersection of the beam and column centrelines.

In tall buildings, higher mode effects shall be accounted for in accordance with specialist literature.

**12.11.3.3** Lateral support to the column at both top and bottom beam flange levels shall be provided so as to resist at least 2 percent of the beam flange strength, except for the case described in **12.11.3.4**.

**12.11.3.4** A plane frame designed as non-sway in the direction perpendicular to its plane, shall be checked for buckling, under the load combination specified in **12.2.3**.

### 12.12 Column Bases

**12.12.1** Fixed column bases and their anchor bolts should be designed to withstand a moment of 1.2 times

the full plastic moment capacity of the column section. The anchor bolts shall be designed to withstand the combined action of shear and tension as well as prying action, if any.

**12.12.2** Both fixed and hinged column bases shall be designed to withstand the full shear under any load case or 1.2 times the shear capacity of the column section, whichever is higher.

## SECTION 13 FATIGUE

### 13.1 General

Structure and structural elements subject to loading that could lead to fatigue failure shall be designed against fatigue as given in this section. This shall however not cover the following:

- a) Corrosion fatigue,
- b) Low cycle (high stress) fatigue,
- c) Thermal fatigue,
- d) Stress corrosion cracking,
- e) Effects of high temperature (> 150° C), and
- f) Effects of low temperature (< brittle transition temperature).

**13.1.1** For the purpose of design against fatigue, different details (of members and connections) are classified under different fatigue class. The design stress range corresponding to various number of cycles, are given for each fatigue class. The requirements of this section shall be satisfied with, at each critical location of the structure subjected to cyclic loading, considering relevant number of cycles and magnitudes of stress range expected to be experienced during the life of the structure.

### 13.2 Design

#### 13.2.1 Reference Design Condition

The standard *S-N* curves for each detail category are given for the following conditions:

- a) Detail is located in a redundant load path, wherein local failure at that detail alone will not lead to overall collapse of the structure.
- b) Nominal stress history at the local point in the detail is estimated/evaluated by a conventional method without taking into account the local stress concentration effects due to the detail.
- c) Load cycles are not highly irregular.
- d) Details are accessible for and subject to regular inspection.
- e) Structure is exposed to only mildly corrosive

environment as in normal atmospheric condition and suitably protected against corrosion (pit depth < 1 mm).

- f) Structure is not subjected to temperature exceeding 150 °C.
- g) Transverse fillet or butt weld connects plates of thickness not greater than 25 mm.
- h) Holes shall not be made in members and connections subjected to fatigue.

Fatigue need not be investigated, if condition in **13.2.2.3**, **13.5.1** or **13.6** is satisfied.

The values obtained from the standard *S-N* curve shall be modified by a capacity reduction factor  $\mu_r$ , when plates greater than 25 mm in thickness are joined together by transverse fillet or butt welding, given by:

$$\mu_r = (25/t_p)^{0.25} \leq 1.0$$

where

$t_p$  = actual thickness in mm of the thicker plate being joined.

No thickness correction is necessary when full penetration butt weld reinforcements are machined flush and proved free of defect through non-destructive testing.

#### 13.2.2 Design Spectrum

##### 13.2.2.1 Stress evaluation

Design stress shall be determined by elastic analysis of the structure to obtain stress resultants and the local stresses may be obtained by a conventional stress analysis method. The normal and shear stresses shall be determined considering all design actions on the members, but excluding stress concentration due to the geometry of the detail. The stress concentration effect is accounted for in detail category classification (*see* Table 26). The stress concentration, however, not characteristic of the detail shall be accounted for separately in the stress calculation.

In the fatigue design of trusses made of members with open sections, in which the end connections are not pinned, the stresses due to secondary bending moments shall be taken into account, unless the slenderness ratio ( $KL/r$ ), of the member is greater than 40.

In the determination of stress range at the end connections between hollow sections, the effect of connection stiffness and eccentricities may be disregarded, provided

- a) the calculated stress range is multiplied by appropriate factor given in Table 24(a) in the case of circular hollow section connections and Table 24(b) in the case of rectangular hollow section connections.

- b) the design throat thickness of fillet welds in the joints is greater than the wall thickness of the connected member.

**13.2.2.2 Design stress spectrum**

In the case of loading events producing non-uniform stress range cycle, the stress spectrum may be obtained by a rational method, such as 'rain flow counting' or an equivalent method.

**13.2.2.3 Low fatigue**

Fatigue assessment is not required for a member, connection or detail, if normal and shear design stress ranges,  $f$  satisfy the following conditions:

$$f \leq 27/\gamma_{mft}$$

or if the actual number of stress cycles,  $N_{sc}$ , satisfies

$$N_{sc} < 5 \times 10^6 \left( \frac{27/\gamma_{mft}}{\gamma_{mf} f} \right)^3$$

where

$\gamma_{mft}, \gamma_{mf}$  = partial safety factors for strength and load, respectively (see 13.2.3), and

$f$  = actual fatigue stress range for the detail.

**Table 24 (a) Multiplying Factors for Calculated Stress Range (Circular Hollow Sections)**  
(Clause 13.2.2.1)

SI No.	Type of Connection	Chords	Verticals	Diagonals	
(1)	(2)	(3)	(4)	(5)	
i)	Gap connections	K type	1.5	1.0	1.3
		N type	1.5	1.8	1.4
ii)	Overlap connections	K type	1.5	1.0	1.2
		N type	1.5	1.65	1.25

**Table 24 (b) Multiplying Factors for Calculated Stress Range (Rectangular Hollow Sections)**  
(Clause 13.2.2.1)

SI No.	Types of Joint	Chords	Verticals	Diagonals	
(1)	(2)	(3)	(4)	(5)	
i)	Gap connections	K type	1.5	1.0	1.5
		N type	1.5	2.2	1.6
ii)	Overlap connections	K type	1.5	1.0	1.3
		N type	1.5	2.0	1.4

**13.2.3 Partial Safety Factors**

**13.2.3.1 Partial safety factor for actions and their effects ( $\gamma_{mf}$ )**

Unless and otherwise the uncertainty in the estimation of the applied actions and their effects demand a higher

value, the partial safety factor for loads in the evaluation of stress range in fatigue design shall be taken as 1.0.

**13.2.3.2 Partial safety factor for fatigue strength ( $\gamma_{mft}$ )**

Partial safety factor for strength is influenced by consequences of fatigue damage and level of inspection capabilities.

**13.2.3.3** Based on consequences of fatigue failure, component details have been classified as given in Table 25 and the corresponding partial safety factor for fatigue strength shall be used:

- a) Fail-safe structural component/detail is the one where local failure of one component due to fatigue crack does not result in the failure of the structure due to availability of alternate load path (redundant system).
- b) Non-fail-safe structural component/detail is the one where local failure of one component leads rapidly to failure of the structure due to its non-redundant nature.

**Table 25 Partial Safety Factors for Fatigue Strength ( $\gamma_{mft}$ )**  
(Clause 13.2.3.3)

SI No.	Inspection and Access	Consequence of Failure	
		Fail-Safe	Non-fail-Safe
(1)	(2)	(3)	(4)
i)	Periodic inspection, maintenance and accessibility to detail is good	1.00	1.25
		1.15	1.35
ii)	Periodic inspection, maintenance and accessibility to detail is poor		

**13.3 Detail Category**

Tables 26 (a) to (d) indicate the classification of different details into various categories for the purpose of assessing fatigue strength. Details not classified in the table may be treated as the lowest detail category of a similar detail, unless superior fatigue strength is proved by testing and/or analysis.

Holes in members and connections subjected to fatigue loading shall not be made:

- a) using punching in plates having thickness greater than 12 mm unless the holes are sub-punched and subsequently reamed to remove the affected material around the punched hole, and
- b) using gas cutting unless the holes are reamed to remove the material in the heat affected zone.

**13.4 Fatigue Strength**

The fatigue strength of the standard detail for the normal or shear fatigue stress range, not corrected for effects discussed in 13.2.1, is given below (see also Fig. 22 and Fig. 23):

a) *Normal stress range*

when  $N_{SC} \leq 5 \times 10^6$

$$f_f = f_{fn} \sqrt[3]{5 \times 10^6 / N_{SC}}$$

when  $5 \times 10^6 \leq N_{SC} \leq 10^8$

$$f_f = f_{fn} \sqrt[3]{5 \times 10^6 / N_{SC}}$$

b) *Shear stress*

$$\tau_f = \tau_{fn} \sqrt[3]{5 \times 10^6 / N_{SC}}$$

where

$f_f, \tau_f$  = design normal and shear fatigue stress range of the detail, respectively, for life cycle of  $N_{SC}$ , and

$f_{fn}, \tau_{fn}$  = normal and shear fatigue strength of the detail for  $5 \times 10^6$  cycles, for the detail category (see Table 26).

**Table 26 (a) Detail Category Classification, Group 1 Non-welded Details**  
(Clauses 13.2.2.1 and 13.3)

Sl No.	Detail Category	Constructional Details	
		Illustration (see Note)	Description
(1)	(2)	(3)	(4)
i)	118		<p><b>Rolled and extruded products</b></p> <p>i) Plates and flats (1) ii) Rolled sections (2) iii) Seamless tubes (3)</p> <p>Sharp edges, surface and rolling flaws to be removed by grinding in the direction of applied stress.</p>
ii)	103		<p><b>Bolted connections</b></p> <p>(4) and (5): Stress range calculated on the gross section and on the net section. Unsupported one-sided cover plate connections shall be avoided or the effect of the eccentricity taken into account in calculating stresses</p> <p><b>Material with gas-cut or sheared edges with no draglines</b></p> <p>(6): All hardened material and visible signs of edge discontinuities to be removed by machining or grinding in the direction of applied stress.</p>
iii)	92		<p><b>Material with machine gas-cut edges with draglines or manual gas-cut material</b></p> <p>(7) : Corners and visible signs of edge discontinuities to be removed by grinding in the direction of the applied stress.</p>

NOTE — The arrow indicates the location and direction of the stresses acting in the basic material for which the stress range is to be calculated on a plane normal to the arrow.



**Table 26 (b) Detail Category Classification, Group 2 Welded, Details — Not in Hollow Sections**  
(Clauses 13.2.2.1 and 13.3)

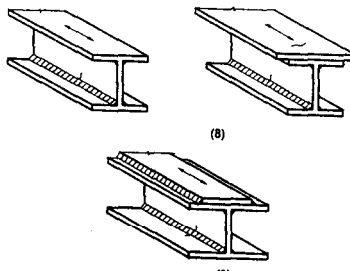
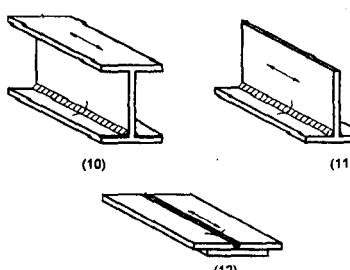
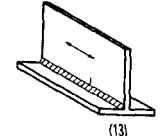
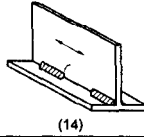
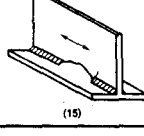
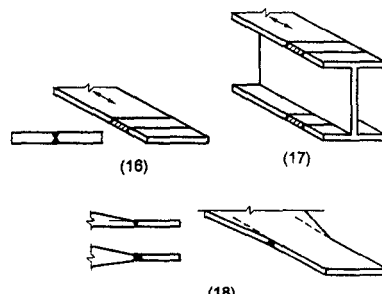
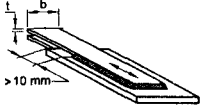
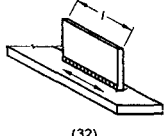
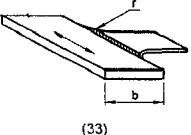
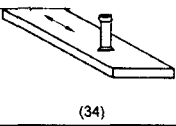
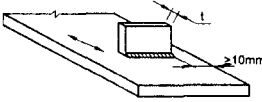
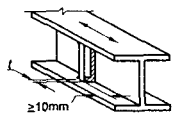
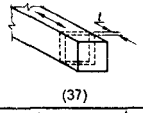
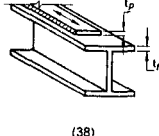
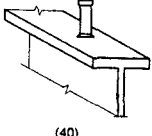
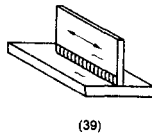
SI No.	Detail Category	Constructional Details	
		Illustration (see Note)	Description
(1)	(2)	(3)	(4)
i)	92		<p><b>Welded plate I-section and box girders with continuous longitudinal welds</b></p> <p>(8) &amp; (9) : Zones of continuous automatic longitudinal fillet or butt welds carried out from both sides and all welds not having un-repaired stop-start positions.</p>
ii)	83		<p><b>Welded plate I-section and box girders with continuous longitudinal welds</b></p> <p>(10) &amp; (11) : Zones of continuous automatic butt welds made from one side only with a continuous backing bar and all welds not having un-repaired stop-start positions.</p> <p>(12) : Zones of continuous longitudinal fillet or butt welds carried out from both sides but containing stop-start positions. For continuous manual longitudinal fillet or butt welds carried out from both sides, use Detail Category 92.</p>
iii)	66		<p><b>Welded plate I-section and box girders with continuous longitudinal welds</b></p> <p>(13) : Zones of continuous longitudinal welds carried out from one side only, with or without stop-start positions.</p>
iv)	59		<p><b>Intermittent longitudinal welds</b></p> <p>(14) : Zones of intermittent longitudinal welds</p>
v)	52		<p><b>Intermittent longitudinal welds</b></p> <p>(15) : Zones containing cope holes in longitudinally welded T-joints. Cope hole not to be filled with weld.</p>
vi)	83		<p><b>Transverse butt welds (complete penetration)</b></p> <p>Weld run-off tabs to be used, subsequently removed and ends of welds ground flush in the direction of stress. Welds to be made from two sides.</p> <p>(16) : Transverse splices in plates, flats and rolled sections having the weld reinforcement ground flush to plate surface. 100 percent NDT inspection, and weld surface to be free of exposed porosity in the weld metal.</p> <p>(17) : Plate girders welded as in (16) before assembly.</p> <p>(18) : Transverse splices as in (16) with reduced or tapered transition with taper <math>\leq 1:4</math></p>

Table 26 (b) (Continued)

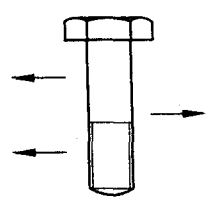
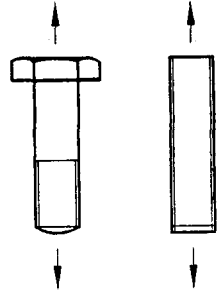
Sl No. (1)	Detail Category (2)		Constructional Details	
			Illustration (see Note) (3)	Description (4)
vii)	66		<p>(19) (20) (21)</p>	<p><b>Transverse butt welds (complete penetration)</b></p> <p>Welds run-off tabs to be used, subsequently removed and ends of welds ground flush in the direction of stress. Welds to be made from two sides.</p> <p>(19) : Transverse splices of plates, rolled sections or plate girders.</p> <p>(20) : Transverse splice of rolled sections or welded plate girders, without cope hole. With cope hole use Detail Category 52, as in (15).</p> <p>(21) : Transverse splices in plates or flats being tapered in width or in thickness where the taper is <math>\leq 1:4</math>.</p>
viii)	59		<p>(22)</p>	<p><b>Transverse butt welds (complete penetration)</b></p> <p>Weld run-off tabs to be used, subsequently removed and ends of welds ground flush in the direction of stress. Welds to be made from two sides.</p> <p>(22) : Transverse splices as in (21) with taper in width or thickness <math>&gt;1:4</math> but <math>\leq 1:2.5</math>.</p>
ix)	52		<p>(23) (24)</p>	<p><b>Transverse butt welds (complete penetration)</b></p> <p>(23) : Transverse butt-welded splices made on a backing bar. The end of the fillet weld of the backing strip shall stop short by more than 10 mm from the edges of the stressed plate.</p> <p>(24) : Transverse butt welds as per (23) with taper on width or thickness <math>&lt;1:2.5</math>.</p>
x)	37		<p>(25)</p>	<p><b>Transverse butt welds (complete penetration)</b></p> <p>(25) : Transverse butt welds as in (23) where fillet welds end closer than 10 mm to plate edge.</p>
xi)	52		<p>(26)</p>	<p><b>Cruciform joints with load-carrying welds</b></p> <p>(26) : Full penetration welds with intermediate plate NDT inspected and free of defects. Maximum misalignment of plates either side of joint to be <math>&lt; 0.15</math> times the thickness of intermediate plate.</p>
xii)	41	(27)	<p>(27) &amp; (28)</p>	<p>(27) : Partial penetration or fillet welds with stress range calculated on plate area.</p> <p>(28) : Partial penetration or fillet welds with stress range calculated on throat area of weld.</p>
	27	(28)		
xiii)	46		<p>(29)</p>	<p><b>Overlapped welded joints</b></p> <p>(29) : Fillet welded lap joint, with welds and overlapping elements having a design capacity greater than the main plate. Stress in the main plate to be calculated on the basis of area shown in the illustration.</p>

Table 26 (b) (Concluded)

Sl No. (1)	Detail Category (2)		Constructional Details		Description (4)
			Illustration (see Note) (3)		
xiv)	41	(30)			<b>Overlapped weld joints</b> (30) : Fillet welded lap joint, with welds and main plate both having a design capacity greater than the overlapping elements. (31) : Fillet welded lap joint, with main plate and overlapping elements both having a design capacity greater than the weld.
xv)	33	(31)	(30) & (31)		
xvi)	66	(32)	(33)	 (32)  (33)	<b>Welded attachments (non-load carrying welds) — Longitudinal welds</b> (32) : Longitudinal fillet welds. Class of detail varies according to the length of the attachment weld as noted. (33) : Gusset welded to the edge of a plate or beam flange. Smooth transition radius ( <i>r</i> ), formed by machining or flame cutting plus grinding. Class of detail varies according to <i>r/b</i> ratio as noted.
	59	$l \leq 50 \text{ mm}$	$1/3 \leq r/b$		
	52	$50 < l \leq 100 \text{ mm}$	$1/6 \leq r/b < 1/3$		
	37	$100 \text{ mm} < l$	—		
	33	—	$r/b < 1/6$		
xvii)	59	 (34)		<b>Welded attachments</b> (34) : Shear connectors on base material (failure in base material).	
xviii)	59	$t \leq 12 \text{ mm}$	 (35)		<b>Transverse welds</b> (35) : Transverse fillet welds with the end of the weld $\geq 10 \text{ mm}$ from the edge of the plate. (36) : Vertical stiffeners welded to a beam or plate girder flange or web by continuous or intermittent welds. In the case of webs carrying combined bending and shear design actions, the fatigue strength shall be determined using the stress range of the principal stresses. (37) : Diaphragms of box girders welded to the flange or web by continuous or intermittent welds.
	52	$t > 12 \text{ mm}$	 (36)		
			 (37)		
xix)	37	$t_f \text{ or } t_p \leq 25 \text{ mm}$	 (38)		<b>Cover plates in beams and plate girders</b> (38) : End zones of single or multiple welded cover plates, with or without a weld across the end. For a reinforcing plate wider than the flange, an end weld is essential.
	27	$t_f \text{ or } t_p > 25 \text{ mm}$			
xx)	67	 (39)		<b>Welds loaded in shear</b> (39) : Fillet welds transmitting shear. Stress range to be calculated on weld throat area. (40) : Stud welded shear connectors (failure in the weld) loaded in shear (the shear stress range to be calculated on the nominal section of the stud).	
		 (40)			

NOTE — The arrow indicates the location and direction of the stresses acting in the basic material for which the stress range is to be calculated on a plane normal to the arrow.

**Table 26 (c) Detail Category Classification, Group 3 Bolts**  
(Clauses 13.2.2.1 and 13.3)

Sl No. (1)	Detail Category (2)	Constructional Details	
		Illustration (see Note) (3)	Description (4)
i)	83	 <p>(41)</p>	<p><b>Bolts in shear (8.8/TB bolting category only)</b></p> <p>(41) : Shear stress range calculated on the minor diameter area of the bolt (<math>A_s</math>).</p> <p>NOTE — If the shear on the joint is insufficient to cause slip of the joint the shear in the bolt need not be considered in fatigue.</p>
ii)	27	 <p>(42)</p>	<p><b>Bolts and threaded rods in tension (tensile stress to be calculated on the tensile stress area, <math>A_t</math>)</b></p> <p>(42) : Additional forces due to prying effects shall be taken into account. For tensional bolts, the stress range depends on the connection geometry.</p> <p>NOTE — In connections with tensioned bolts, the change in the force in the bolts is often less than the applied force, but this effect is dependent on the geometry of the connection. It is not normally required that any allowance for fatigue be made in calculating the required number of bolts in such connections.</p>

NOTE — The arrow indicates the location and direction of the stresses acting in the basic material for which the stress range is to be calculated on a plane normal to the arrow.

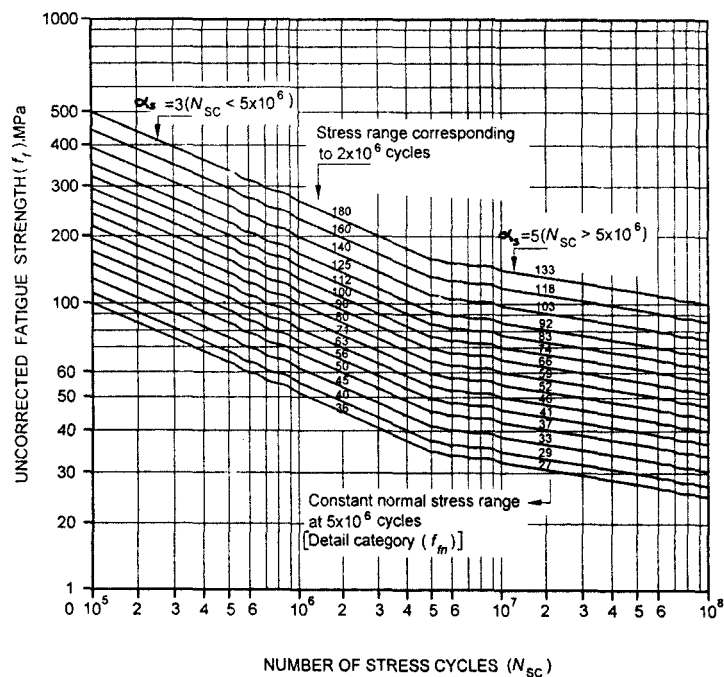
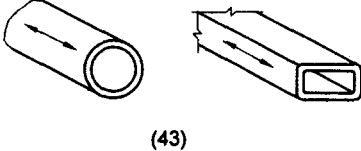
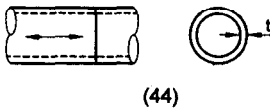
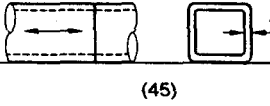
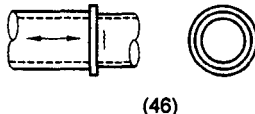
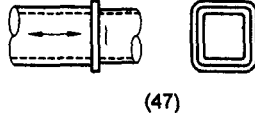
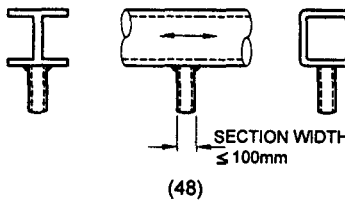




FIG. 22 S-N CURVE FOR NORMAL STRESS

**Table 26 (d) Detail Category Classification, Group 4**  
**Welded Details in Hollow Sections**  
*(Clause 13.2.2.1 and 13.3)*

Sl No. (1)	Detail Category (2)	Constructional Details	
		Illustration (see Note) (3)	Description (4)
i)	103		<b>Continuous automatic longitudinal welds</b> (43) : No stop-starts, or as manufactured, proven free to detachable discontinuities.
ii)	66 ( $t \geq 8$ mm)		<b>Transverse butt welds</b> (44) : Butt-welded end-to-end connection of circular hollow sections.  NOTE — Height of the weld reinforcement less than 10 percent of weld with smooth transition to the plate surface. Welds made in flat position and proven free to detachable discontinuities.
	52 ( $t < 8$ mm)		
iii)	52 ( $t \geq 8$ mm)		(45) : Butt-welded end-to-end connection of rectangular hollow sections
	41 ( $t < 8$ mm)		
iv)	41 ( $t \geq 8$ mm)		<b>Butt welds to intermediate plate</b> (46) : Circular hollow sections, end-to-end butt-welded with an intermediate plate.
	37 ( $t < 8$ mm)		
v)	37 ( $t \geq 8$ mm)		(47) Rectangular hollow sections, end-to-end butt welded with an intermediate plate
	30 ( $t < 8$ mm)		
vi)	52		<b>Welded attachments (non-load-carrying)</b> (48) : Circular or rectangular hollow section, fillet welded to another section. Section width parallel to stress direction $\leq 100$ mm.
vii)	33 ( $t < 8$ mm)		<b>Fillet welds to intermediate plate</b> (49) : Circular hollow sections, end-to-end fillet welded with an intermediate plate.
	29 ( $t < 8$ mm)		
viii)	29 ( $t \geq 8$ mm)		(50) : Rectangular hollow sections, end-to-end fillet welded with an intermediate plate.
	27 ( $t < 8$ mm)		

NOTE — The arrow indicates the location and direction of the stresses acting in the basic material for which the stress range is to be calculated on a plane normal to the arrow.

**13.5 Fatigue Assessment**

The design fatigue strength for  $N_{SC}$  life cycles ( $f_{fd}, \tau_{fd}$ ) may be obtained from the standard fatigue strength for  $N_{SC}$  cycles by multiplying with correction factor,  $\mu_r$ , for thickness, as mentioned in 13.2.1 and dividing by partial safety factor given in Table 25.

**13.5.1 Exemptions**

At any point in a structure if the actual normal and shear stress range  $f$  and  $\tau$  are less than the design fatigue strength range corresponding to  $5 \times 10^6$  cycles with appropriate partial safety factor, no further assessment for fatigue is necessary at that point.

**13.5.2 Stress Limitations**

**13.5.2.1** The maximum (absolute) value of the normal and shear stresses shall never exceed the elastic limit ( $f_y, \tau_y$ ) for the material under cyclic loading.

**13.5.2.2** The maximum stress range shall not exceed  $1.5 f_y$  for normal stresses and  $1.5 f_y/\sqrt{3}$  for the shear stresses under any circumstance.

**13.5.2.3 Constant stress range**

The actual normal and shear stress range  $f$  and  $\tau$  at a point of the structure subjected to  $N_{SC}$  cycles in life shall satisfy.

$$f \leq f_{fd} = \mu_r f_f / \gamma_{mf}$$

$$\tau \leq \tau_{fd} = \mu_r \tau_f / \gamma_{mf}$$

where

$\mu_r$  = correction factor (see 13.2.1),

$\gamma_{mf}$  = partial safety factor against fatigue failure, given in Table 25, and

$f_f, \tau_f$  = normal and shear fatigue strength ranges for the actual life cycle,  $N_{SC}$ , obtained from 13.4.

**13.5.2.4 Variable stress range**

Fatigue assessment at any point in a structure, wherein variable stress ranges  $f_{fi}$  or  $\tau_{fi}$  for  $n_i$  number of cycles ( $i=1$  to  $r$ ) are encountered, shall satisfy the following:

a) For normal stress ( $f$ )

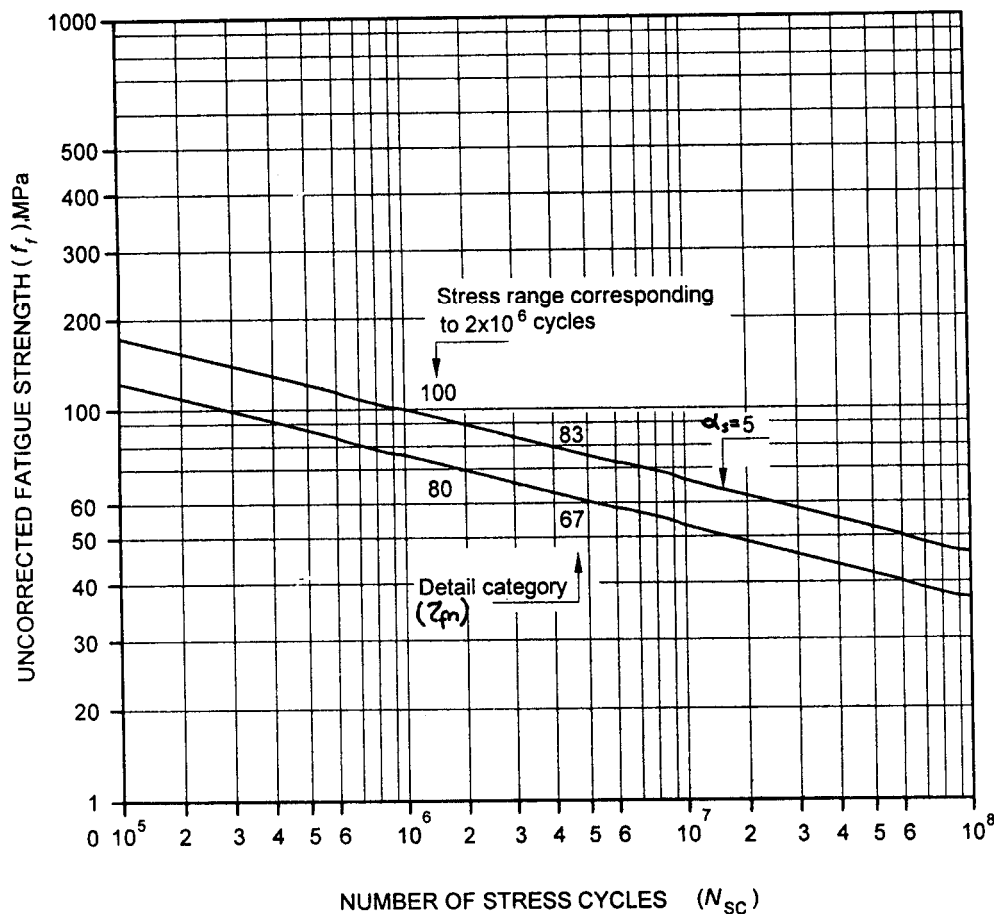


FIG. 23 S-N CURVE FOR SHEAR STRESS

$$\frac{\sum_{i=1}^{\gamma_s} n_i f_i^3}{5 \times 10^6 (\mu f_{fn} / \gamma_{mft})^3} + \frac{\sum_{j=\gamma_s}^r n_j f_j^5}{5 \times 10^6 (\mu f_{fn} / \gamma_{mft})^5} \leq 1.0$$

b) For shear stresses ( $\tau$ )

$$\sum_{i=1}^r n_i \tau_i^5 \leq 5 \times 10^6 (\mu \tau_{fn} / \gamma_{mft})^5$$

where  $\gamma_s$  is the summation upper limit of all the normal stress ranges ( $f_i$ ) having magnitude lesser than  $(\mu_c f_{fn} / \gamma_{mft})$  for that detail and the lower limit of all the normal stress ranges ( $f_j$ ) having magnitude greater than  $(\mu_c f_{fn} / \gamma_{mft})$  for the detail. In the above summation all normal stress ranges,  $f_i$ , and  $\tau_i$  having magnitude less than  $0.55\mu_c f_{fn}$ , and  $0.55\mu_c \tau_{fn}$  may be disregarded.

### 13.6 Necessity for Fatigue Assessment

- a) Fatigue assessment is not normally required for building structures except as follows:
- 1) Members supporting lifting or rolling loads,
  - 2) Member subjected to repeated stress cycles from vibrating machinery,
  - 3) Members subjected to wind induced oscillations of a large number of cycles in life, and
  - 4) Members subjected to crowd induced oscillations of a large number of cycles in life.
- b) No fatigue assessment is necessary if any of the following conditions is satisfied.
- 1) The highest normal stress range  $f_{f, Max}$  satisfies

$$f_{f, Max} \leq 27\mu_c / \gamma_{mft}$$

- 2) The highest shear stress range  $\tau_{f, Max}$  satisfies

$$\tau_{f, Max} \leq 67\mu_c / \gamma_{mft}$$

- 3) The total number of actual stress cycles  $N_{sc}$ , satisfies

$$N_{sc} \leq 5 \times 10^6 \left( \frac{27\mu_c}{\gamma_{mft} f_{feq}} \right)^3$$

where

$f_{feq}$  = equivalent constant amplitude stress range in MPa given by

$$f_{feq} = \left[ \frac{\sum_{i=1}^{\gamma_s} n_i f_{fi}^3 + \sum_{j=\gamma_s}^r n_j f_{fj}^5}{n} \right]^{1/3}$$

where

$$n = \sum_{i=1}^{\gamma_s} n_i$$

$f_{fi}, f_{fj}$  = stress ranges falling above and below the  $f_{fn}$ , the stress range corresponding to the detail at  $5 \times 10^6$  number of life cycles.

## SECTION 14 DESIGN ASSISTED BY TESTING

### 14.1 Need for Testing

Testing of structures, members or components of structures is not required when designed in accordance with this standard. Testing may be accepted as an alternative to calculations or may become necessary in special circumstances.

Testing of a structural system, member or component may be required to assist the design in the following cases:

- a) When the calculation methods available are not adequate for the design of a particular structure, member or component, testing shall be undertaken in place of design by calculation or to supplement the design by calculation;
- b) Where rules or methods for design by calculation would lead to uneconomical design, experimental verification may be undertaken to avoid conservative design;
- c) When the design or construction is not entirely in accordance with sections of this standard, experimental verification is recommended;
- d) When confirmation is required on the consistency of production of material, components, members or structures originally designed by calculations or testing; and
- e) When the actual performance of an existing structure capacity is in question, testing shall be used to confirm it.

14.1.1 Testing of structural system, member or component shall be of the following categories:

- a) *Proof testing* — The application of test loads to a structure, sub-structure, member or connection to ascertain the structural characteristics of only that specific unit.

- b) *Prototype testing* — Testing of structures, sub-structures, members or connections is done to ascertain the structural characteristics of a class of such structures, sub-structures members or connection, which are nominally identical to the units tested.

## 14.2 Types of Test

### 14.2.1 Acceptance Test

This is intended as a non-destructive test for confirming structural performance. It should be recognized that the loading applied to certain structures might cause permanent distortions. Such effects do not necessarily indicate structural failure in acceptance test. However, the possibility of their occurrence should be agreed to before testing.

The load for acceptance test,  $F_{\text{test, a}}$  shall be determined from:

$$F_{\text{test, a}} = (1.0 \times \text{self weight}) + (1.15 \times \text{remainder of the permanent load}) + (1.25 \times \text{variable load}).$$

The assembly shall satisfy the following criteria:

- It shall demonstrate substantially linear behaviour under test loading, and
- On removal of the test load, the residual deflection shall not exceed 20 percent of the maximum-recorded deflection.

If the above criteria are not satisfied the test may be repeated one more time only, when the assembly shall satisfy the following criteria:

- It shall demonstrate substantially linear behaviour on the second application of test loading, and
- Corresponding recorded residual deflection in the second test shall not exceed 10 percent of the maximum deflection during the test.

### 14.2.2 Strength Test

Strength test is used to confirm the calculated resistance of a structure or component. Where a number of items are to be constructed to a common design, and one or more prototypes are tested to confirm their strength, the others may be accepted without any additional test, provided they are similar in all relevant respects to the prototype.

Before carrying out the strength test, the specimen should first be subjected to and satisfy the acceptance test. Since the resistance of the assembly under test depends on the material properties, the actual yield strength of all the steel materials in the assembly shall be determined from coupon (test piece as defined in

IS 1608) tests. The mean value of the yield strength,  $f_{ym}$ , taken from such tests shall be determined with due regard to the importance of each element in the assembly. The strength test load  $F_{\text{test, s}}$  (including self weight) shall be determined from:

$$F_{\text{test, s}} = \gamma_{mi} F_d (f_y/f_y)$$

where

$f_y$  = characteristic yield stress of the material as assumed in the design,

$F_d$  = factored design load for the ultimate limit state, and

$\gamma_{mi}$  = partial safety factor for the type of failure, as prescribed in this standard.

At this load there shall be no failure by buckling or rupture of any part of the structure or component tested. On removal of the test load, the deflection should decrease by at least 20 percent of the maximum deflection at  $F_{\text{test, s}}$ .

### 14.2.3 Test to Failure (Ultimate Strength Test)

The objective of a test to failure is to determine the design resistance from the ultimate resistance. In this situation it is still desirable to carry out the acceptance and strength tests, before test to failure.

Not less than three tests shall be carried out on nominally identical specimens. An estimate should be made of the anticipated ultimate resistance as a basis for such tests. During a test to failure, the loading shall first be applied in increments up to the strength test load. Subsequent load increments shall then be determined from consideration of the principal load deflection plot. The test load resistance,  $F_{\text{test, R}}$  shall be determined as that load at which the specimen is unable to sustain any further increase in load. At this load, gross permanent distortion is likely to have occurred and in some cases such large gross deformation may define the test limit. If the deviation of any individual test result exceeds 10 percent of the mean value obtained for all the three tests, at least three more tests shall be carried out. When the deviation from the mean does not exceed 10 percent of the mean, the design resistance may be evaluated as given below:

- When the failure is ductile, the design resistance,  $F_d$  may be determined from:

$$F_d = 0.9 F_{\text{test, Min}} (f_y/f_{ym}) / \gamma_{m0}$$

where

$F_{\text{test, Min}}$  = minimum test result from the tests to failure,

$f_{ym}$  = average yield strength as obtained from the material tests, and



$f_y$  = characteristic yield stress of the grade of steel.

- b) In the case of a sudden (brittle) rupture type failure, the design resistance may be determined from:

$$F_d = 0.9F_{\text{test, Min}}(f_u/f_{\text{um}}) / \gamma_{m1}$$

where

$f_u$  = characteristic ultimate stress of the grade of steel used, and

$f_{\text{um}}$  = average ultimate tensile strength of the material obtained from tests.

- c) In the case of a sudden (brittle) buckling type failure, the design resistance shall be determined from:

$$F_d = 0.75F_{\text{test, Min}}(f_y/f_{ym}) / \gamma_{m0}$$

- d) In ductile buckling type failure in which the relevant slenderness  $\lambda$  can be reliably assessed, the design resistance may be determined from:

$$F_d = 0.9F_{\text{test, Min}} \left[ (\chi f_y / \chi_m f_{ym}) / \gamma_{m0} \right]$$

where

$\chi$  = reduction factor for the relevant buckling curve, and

$\chi_m$  = value of  $\chi$  when the yield strength is  $f_{ym}$ .

#### 14.2.4 Check Tests

Where a component or assembly is designed on the basis of strength tests or tests to failure and a production run is carried out of such items, an appropriate number of samples (not less than two) shall be selected from each production batch at random for check tests.

**14.2.4.1** The samples shall be carefully examined to ensure that they are similar in all respects to the prototype tested, particular attention being given to the following:

- Dimensions of components and connections;
- Tolerance and workmanship; and
- Quality of steel used, checked with reference to mill test certificates.

**14.2.4.2** Where it is not possible to determine either the variations or the effect of variations from the prototype, an acceptance test shall be carried out as a check test.

**14.2.4.3** In this check test, the deflections shall be measured at the same positions as in the acceptance test of the prototype. The maximum measured deflection shall not exceed 120 percent of the deflection

recorded during the acceptance test on the prototype and the residual deflection should not be more than 105 percent of that recorded for the prototype.

#### 14.3 Test Conditions

- a) Loading and measuring devices shall be calibrated in advance.

- b) The design of the test rig shall be such that:

- Loading system adequately simulates the magnitude and distribution of the loading;
- It allows the specimen to perform in a manner representative of service conditions;
- Lateral and torsional restraint, if any, should be representative of those in service;
- Specimen should be free to deflect under load according to service condition;
- Loading system shall be able to follow the movements of the specimen without interruption or abnormal restraints; and
- Inadvertent eccentricities at the point of application of the test loads and at the supports are avoided.

- c) Test load shall be applied to the unit at a rate as uniform as practicable.

- d) Deflections should be measured at sufficient points of high movements to ensure that the maximum value is determined.

- e) If the magnitude of stresses in a specimen is to be determined, the strain at the desired location may be measured and the corresponding stress calculated.

- f) Prior to any test, preliminary loading (not exceeding the characteristic values of the relevant loads) may be applied and then removed, in order to set the test specimen on to the test rig.

#### 14.4 Test Loading

**14.4.1** Where the self-weight of the specimen is not representative of the actual permanent load in service, allowance for the difference shall be made in the calculation of test loads to be applied.

**14.4.2** On the attainment of maximum load for either acceptance or strength tests, this load shall be maintained for at least 1 h. Reading of load and deflection shall be taken at intervals of 15 min and the loading shall be maintained constant until there is no significant increase in deflection during a 15 min period or until at least 1 h has elapsed.

**14.4.3** The test load shall be equal to the design load for the relevant limit state in proof testing.

**14.4.4** The test load in prototype testing shall be equal to the design load for the relevant limit state as multiplied by the appropriate factor given in Table 27.

**Table 27 Factors to Allow for Variability of Structural Units**

Sl No.	No. of Similar Units to be Tested	For Strength Limit State	For Serviceability Limit State
(1)	(2)	(3)	(4)
i)	1	1.5	1.2
ii)	2	1.4	1.2
iii)	3	1.3	1.2
iv)	4	1.3	1.1
v)	5	1.3	1.1
vi)	10	1.2	1.1

## 14.5 Criteria for Acceptance

### 14.5.1 Acceptance for Strength

The test structure, sub-structure, member or connection shall be deemed to comply with the requirements for strength if it is able to sustain the strength test load for at least 15 min.

It shall then be inspected to determine the nature and extent of any damage incurred during the test. The effects of the damage shall be considered and if necessary appropriate repairs to the damaged parts carried out.

### 14.5.2 Acceptance for Serviceability

The maximum deformation of the structure or member under the serviceability limit state test load shall be within the serviceability limit values appropriate to the structure.

## SECTION 15 DURABILITY

### 15.1 General

A durable steel structure is one that performs satisfactorily the desired function in the working environment under the anticipated exposure condition during its service life, without deterioration of the cross-sectional area and loss of strength due to corrosion. The material used, the detailing, fabrication, erection and surface protection measures should all address the corrosion protection and durability requirements.

### 15.2 Requirements for Durability

#### 15.2.1 Shape, Size, Orientation of Members, Connections and Details

The design, fabrication and erection details of exposed

structures should be such that good drainage of water is ensured. Standing pool of water, moisture accumulation and rundown of water for extended duration shall be avoided.

The details of connections should ensure that:

- All exposed surfaces are easily accessible for inspection and maintenance; and
- All surfaces, not so easily accessible are completely sealed against ingress of moisture.

### 15.2.2 Exposure Condition

#### 15.2.2.1 General environment

The general environment, to which a steel structure is exposed during its working life is classified into five levels of severity, as given in Table 28.

**Table 28 Environmental Exposure Conditions**

Sl No.	Environmental Classifications	Exposure Conditions
(1)	(2)	(3)
i)	Mild	Surfaces normally protected against exposure to weather or aggressive condition as in interior of buildings, except when located in coastal areas
ii)	Moderate	Structural steel surfaces: <ol style="list-style-type: none"> <li>exposed to condensation and rain</li> <li>continuously under water</li> <li>exposed to non-aggressive soil/ groundwater</li> <li>sheltered from saturated salt air in coastal areas</li> </ol>
iii)	Severe	Structural steel surfaces: <ol style="list-style-type: none"> <li>exposed to severe frequent rain</li> <li>exposed to alternate wetting and drying</li> <li>severe condensation</li> <li>completely immersed in sea water</li> <li>exposed to saturated salt air in coastal area</li> </ol>
iv)	Very severe	Structural steel surface exposed to: <ol style="list-style-type: none"> <li>sea water spray</li> <li>corrosive fumes</li> <li>aggressive sub soil or ground water</li> </ol>
v)	Extreme	Structural steel surfaces exposed to: <ol style="list-style-type: none"> <li>tidal zones and splash zones in the sea</li> <li>aggressive liquid or solid chemicals</li> </ol>

#### 15.2.2.2 Abrasion

Specialist literature may be referred for durability of surfaces exposed to abrasive action as in machinery, conveyor belt support system, storage bins for grains or aggregates.

**15.2.2.3 Exposure to sulphate attack**

Appropriate coatings may be used when surfaces of structural steel are exposed to concentration of sulphates (SO<sub>3</sub>) in soil, ground water, etc.

When exposed to very high sulphate concentrations of more than 2 percent in soil and 5 percent in water, some form of lining such as polyethylene, polychloroprene sheet or surface coating based on asphalt, chlorinated rubber, epoxy or polymethane material should be used to completely avoid access of the solution to the steel surface.

**15.2.3 Corrosion Protection Methods**

The methods of corrosion protection are governed by actual environmental conditions as specified in IS 9077

and IS 9172. The main corrosion protection methods are given below:

- a) Controlling the electrode potential,
- b) Inhibitors, and
- c) Inorganic/metal coatings or organic/paint systems.

**15.2.4 Surface Protection**

**15.2.4.1** In the case of mild exposure, a coat of primer after removal of any loose mill scale may be adequate. As the exposure condition becomes more critical, more elaborate surface preparations and coatings become necessary. In case of extreme environmental classification, protection shall be as per specialist literature. Table 29 gives guidance to protection of steelwork for different desired lives.

**Table 29 (a) Protection Guide for Steel Work Application — Desired Life of Coating System in Different Environments**

Sl No.	Atmospheric Condition/ Environmental Classification	Coating System					
		1	2	3	4	5	6
(1)	(2)	(3)	(4)	(5)	(6)	(7)	(8)
i)	Normal inland (rural and urban areas), mild	12 years	18 years	20 years	About 20 years	About 20 years	Above 20 years
ii)	Polluted inland (high airborne sulphur dioxide), moderate	10 years	15 years	12 years	About 18 years	15-20 years	Above 20 years
iii)	Normal coastal (as normal inland plus high airborne salt levels), severe	10 years	12 years	20 years	About 20 years	About 20 years	Above 20 years
iv)	Polluted coastal (as polluted inland plus high airborne salt levels), very severe or extreme	8 years	10 years	10 years	About 15 years	15-20 years	Above 20 years

**Table 29 (b) (i) Protection Guide for Steel Work Application — Specification for Different Coating System (Shop Applied Treatments)**  
(Clause 15.2.4.1)

Sl No.	Protection	Coating System					
		1	2	3	4	5	6
(1)	(2)	(3)	(4)	(5)	(6)	(7)	(8)
i)	Surface preparation	Blast clean	Blast clean	Blast clean	Blast clean	Girt blast	Blast clean
ii)	Pre-fabrication primer	Zinc phosphate epoxy, 20 µm	2 pack zinc-rich epoxy, 20 µm	—	2 pack zinc-rich epoxy, 20 µm	—	Ethyl zinc silicate, 20 µm
iii)	Post-fabrication primer	High-build zinc phosphate modified alkyd, 60 µm	2 pack zinc-rich epoxy, 20 µm	Hot dip galvanized, 85 µm	2 pack zinc-rich epoxy, 25 µm	Sprayed zinc or sprayed aluminium	Ethyl zinc silicate, 60 µm
iv)	Intermediate coat	—	High-build zinc phosphate, 25 µm	—	2 pack epoxy micaceous iron oxide	Sealer	Chlorinated rubber alkyd, 35 µm
v)	Top coat	—	—	—	2 pack epoxy micaceous iron oxide, 85 µm	Sealer	—

**Table 29 (b) (ii) Protection Guide for Steel Work Application — Specification for Different Coating System (Site Applied Treatments)**  
(Clause 15.2.4.1)

SI No.	Protection	Coating System					
		1	2	3	4	5	6
(1)	(2)	(3)	(4)	(5)	(6)	(7)	(8)
i)	Surface preparation	As necessary	As necessary	No site treatment	As necessary	No site treatment	As necessary
ii)	Primer	Touch in	Touch in	—	—	—	Touch in
iii)	Intermediate coat	—	Modified Alkyd Micaceous iron oxide, 50 µm	—	Touch In	—	High-build micaceous iron oxide Chlorinated rubber Micaceous, 75 µm
iv)	Top coat	High-build Alkyd finish, 60µm	Modified Alkyd Micaceous iron oxide, 50 µm	—	High-build chlorinated rubber	—	High-build iron oxide Chlorinated rubber, 75 µm

**15.2.4.2** Steel surfaces shall be provided with at least one coat of primer immediately after its surface preparation such as by sand blasting to remove all mill scale and rust and to expose the steel.

**15.2.4.3** Steel without protective coating shall not be stored for long duration in out door environment.

**15.2.4.4** Surfaces to transfer forces by friction as in HSFG connections shall not be painted. However it shall be ensured that moisture is not trapped on such surfaces after pretensioning of bolts by proper protective measures.

**15.2.4.5** Members to be assembled by welding shall not be pre-painted at regions adjacent to the location of such welds. However, after welding, appropriate protective coatings shall be applied in the region, as required by the exposure conditions. If the contact surfaces cannot be properly protected against ingress of moisture by surface coating, they may be completely sealed by appropriate welds.

**15.2.4.6** Pre-painted members shall be protected against abrasion of the coating during transportation, handling and erection.

#### 15.2.5 Special Steels

Steels with special alloying elements and production process to obtain better corrosion resistance may be used as per specialist literature.

## SECTION 16 FIRE RESISTANCE

### 16.1 Requirements

The requirements shall apply to steel building elements designed to exhibit a required fire-resistance level (FRL) as per the relevant specifications.

**16.1.1** For protected steel members and connections, the thickness of protection material ( $h_p$ ) shall be greater than or equal to that required to give a period of structural adequacy (PSA) greater than or equal to the required FRL.

**16.1.2** For unprotected steel members and connections, the exposed surface area to mass ratio ( $k_{sm}$ ) shall be less than or equal to that required to give a PSA equal to the required FRL.

### 16.2 Fire Resistance Level

The required FRL shall be as prescribed in IS 1641, IS 1642 and IS 1643, as appropriate or in building specifications or as required by the user or the city ordinance. The FRL specified in terms of the duration (in minutes) of standard fire load without collapse depends upon:

- the purpose for which structure is used, and
- the time taken to evacuate in case of fire.

**16.3 Period of Structural Adequacy (PSA)**

16.3.1 The calculation of PSA involves:

- a) Calculation of the strength of the element as a function of temperature of the element and the determination of limiting temperature;
- b) Calculation of the thermal response of the element, that is calculation of the variation of the temperature of the element or the parts of the element with time, when exposed to fire; and
- c) Determination of PSA at which the temperature of the element or parts of the element reaches the limiting temperature.

**16.3.2 Determination of Period of Structural Adequacy**

The period of structural adequacy (PSA) shall be determined using one of the following methods:

- a) *By calculation:*
  - 1) determining the limiting temperature of the steel ( $T_l$ ) in accordance with 16.5 ; and
  - 2) determining the PSA as the time (in min) from the start of the test to the time at which the limiting steel temperature ( $t$ ) is attained, in accordance with 16.6 for protected members and 16.7 for unprotected members.
- b) By direct application of a single test in accordance with 16.8; or
- c) By calculation of the temperature of the steel member by using a rational method of analysis confirmed by test data or by methods available in specialist literature.

**16.4 Variation of Mechanical Properties of Steel with Temperature**

**16.4.1 Variation of Yield Stress with Temperature**

The influence of temperature on the yield stress of steel shall be taken as follows for structures of mild steels and high strength low alloy steels:

$$\frac{f_y(T)}{f_y(20)} = \frac{905 - T}{905} \leq 1.0$$

where

$f_y(T)$  = yield stress of steel at  $T$  °C,

$f_y(20)$  = yield stress of steel at 20°C (room temperature), and

$T$  = temperature of the steel in °C.

This relationship is shown by Curve 1 in Fig. 24.

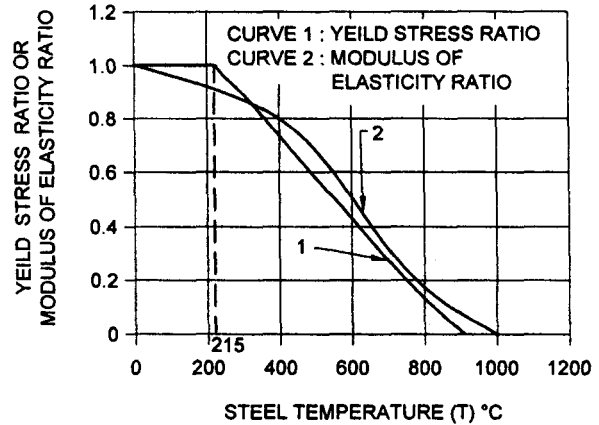


FIG. 24 VARIATION OF MECHANICAL PROPERTIES OF STEEL WITH TEMPERATURE

For temperature less than 215°C no reduction in the yield stress need to be considered.

**16.4.2 Variation of Modulus of Elasticity with Temperature**

The influence of temperature on the modulus of elasticity shall be taken as follows for structures of mild steels and high strength low alloy steels:

$$\frac{E(T)}{E(20)} = 1.0 + \left[ \frac{T}{2000 \left[ \ln \left( \frac{T}{1100} \right) \right]} \right]$$

when  $0^\circ\text{C} < T \leq 600^\circ\text{C}$

$$= \frac{690 \left( 1 - \frac{T}{1000} \right)}{T - 53.5}$$

when  $600^\circ\text{C} < T \leq 1000^\circ\text{C}$

$E(T)$  = modulus of elasticity of steel at  $T$  °C, and

$E(20)$  = modulus of elasticity of steel at 20°C (room temperature).

This relationship is shown by curve 2 in Fig. 24.

16.4.3 For special steel with higher temperature resistance, such as TMCP steels, the manufacturer's recommendation shall be used to obtain the variation of yield strength and modulus of elasticity of steel with temperature.

**16.5 Limiting Steel Temperature**

The limiting steel temperature ( $T_l$ ) in degree Celsius in the case of ordinary steels, shall be calculated as follows:

$$T_1 = 905 - 690 r_f$$

where

$r_f$  = ratio of the design action on the member under fire to the design capacity of the member ( $R_d = R_u/\gamma_m$ ) at room temperature,

$R_d, R_u$  = design strength and ultimate strength of the member at room temperature respectively, and

$\gamma_m$  = partial safety factor for strength.

The design action under fire shall consider the following:

- Reduced bond likely under fire, and
- Effects of restraint to expansion of the elements during fire.

Limiting steel temperature for special steels may be appropriately calculated using the thermal characteristics of the material obtained from the supplier of the steel.

### 16.6 Temperature Increase with Time in Protected Members

**16.6.1** The time ( $t$ ) at which the limiting temperature ( $T_1$ ) is attained shall be determined by calculation on the basis of a suitable series of fire tests in accordance with 16.6.2 or from the results of a single test in accordance with 16.6.3.

**16.6.1.1** For beams and for all members with a four-sided fire exposure condition, the limiting temperature ( $T_1$ ) shall be taken as the average of all of the temperatures measured at the thermocouple locations on all sides.

**16.6.1.2** For columns with a three-sided fire exposure condition, the limiting temperature ( $T_1$ ) shall be taken as the average of the temperatures measured at the thermocouple locations on the face farthest from the wall. Alternatively, the temperatures from members with a four-sided fire exposure condition and having the same surface area to mass ratio may be used.

#### 16.6.2 Temperature Based on Test Series

Calculation of the variation of steel temperature with time shall be by interpolation of the results of a series of fire tests using the regression analysis equation specified in 16.6.2.1, subject to the limitations and conditions of 16.6.2.3.

##### 16.6.2.1 Regression analysis

The relationship between temperature ( $T$ ) and time ( $t$ ) for a series of tests on a group shall be calculated by least-square regression as follows:

$$t = k_0 + k_1 h_i + k_2 \frac{h_i}{k_{sm}} + k_3 T + k_4 h_i T + k_5 \frac{h_i T}{k_{sm}} + k_6 \frac{T}{k_{sm}}$$

where

$t$  = time from the start of the test, in min;

$k_0$  to  $k_6$  = regression coefficients from test data (see 16.6.2.2.);

$h_i$  = thickness of fire protection material, in mm;

$T$  = steel temperature, in degrees celsius obtained from test as given in 16.6.1,  $T > 250^\circ\text{C}$ ; and

$k_{sm}$  = exposed surface area to mass ratio, in  $10^3 \text{ mm}^2/\text{kg}$ .

**16.6.2.2** In lieu of test results, the values for coefficients in Table 30 may be used in the equation 16.6.2.1 when the test satisfies the conditions specified in 16.6.2.3.

Table 30 Regression Coefficients,  $k$

$k_0$	$k_1$	$k_2$	$k_3$	$k_4$	$k_5$	$k_6$
(1)	(2)	(3)	(4)	(5)	(6)	(7)
-25.90	1.698	-13.71	0.0300	0.0005	0.5144	6.633

##### 16.6.2.3 Limitations and conditions on use of regression analysis

Test data to be utilized in accordance with 16.6.2.1, shall satisfy the following:

- Steel members shall be protected with board, sprayed blanket or similar insulation materials having a dry density less than  $1\,000 \text{ kg/m}^3$ ;
- All tests shall incorporate the same fire protection system;
- All members shall have the same fire exposure condition;
- Test series shall include at least nine tests;
- Test series may include prototypes which have not been loaded provided that stickability has been demonstrated; and
- All members subject to a three-sided fire exposure condition shall be within a group in accordance with 16.9.

The regression equation obtained for one fire protection system may be applied to another system using the same fire protection material and the same fire exposure condition provided that stickability has been demonstrated for the second system.

A regression equation obtained using prototypes with a four-sided fire exposure condition may be applied to a member with a three-sided fire exposure condition provided that stickability has been demonstrated for the three-sided case.

### 16.6.3 Temperature Based on Single Test

The variation of steel temperature with time measured in a standard fire test may be used without modification provided:

- Fire protection system is the same as the prototype;
- Fire exposure condition is the same as the prototype;
- Fire protection material thickness is equal to or greater than that of the prototype;
- Surface area to mass ratio is equal to or less than that of the prototype; and
- Where the prototype has been submitted to a standard fire test in an unloaded condition, stickability has been separately demonstrated.

### 16.6.4 Parameters of Importance in the Standard Fire Test

- Specimen type, loading, configuration;
- Exposed surface area to mass ratio;
- Insulation type, thermal properties and thickness; and
- Moisture content of the insulation material.

### 16.7 Temperature Increase with Time in Unprotected Members

The time ( $t$ ) at which the limiting temperature ( $T_l$ ) is attained shall be calculated using the following equations:

- Three-sided fire exposure condition

$$t = 5.2 + 0.022 \ 1 \ T + \frac{0.433T_l}{k_{sm}}$$

- Four-sided fire exposure condition

$$t = 4.7 + 0.026 \ 3T + \frac{0.213T_l}{k_{sm}}$$

where

- $t$  = time from the start of the test, in min,  
 $T$  = steel temperature, in °C,  $500 \text{ °C} \leq T \leq 750 \text{ °C}$ , and  
 $k_{sm}$  = exposed surface area to mass ratio,  $2 \times 10^3 \text{ mm}^2/\text{kg} \leq k_{sm} \leq 35 \times 10^3 \text{ mm}^2/\text{kg}$ .

For temperatures below 500°C, linear interpolation shall be used, based on the time at 500°C and an initial temperature of 20°C at  $t$  equals 0.

### 16.8 Determination of PSA from a Single Test

The period of structural adequacy (PSA) determined from a single test may be applied without modification provided:

- Conditions, specified in 16.6.3 are satisfied,
- Conditions of support are the same as the prototype and the restraints are not less favourable than those of the prototype, and
- Ratio of the design load for fire to the design capacity of the member is less than or equal to that of the prototype.

### 16.9 Three-Sided Fire Exposure Condition

Members subject to a three-sided fire exposure condition shall be considered in separate groups unless the following conditions are satisfied:

- The characteristics of the members of a group as given below, shall not vary from one another by more than

- Concrete density:  $\frac{\text{highest in group}}{\text{lowest in group}} \leq 1.25$ , and

- Effective thickness ( $h_e$ ):  $\frac{\text{largest in group}}{\text{smallest in group}} \leq 1.25$ .

where the effective thickness ( $h_e$ ) is equal to the cross-sectional area excluding voids per unit width, as shown in Fig. 25A.

- Rib voids shall either be:
  - all open; or
  - all blocked as shown in Fig. 25B.
- Concrete slabs may incorporate permanent steel deck formwork.

### 16.10 Special Considerations

#### 16.10.1 Connections

Connections shall be protected with the maximum thickness of fire protection material required for any of the members framing into the connection to achieve their respective fire-resistance levels. This thickness shall be maintained over all connection components, including bolt heads, welds and splice plates.

#### 16.10.2 Web Penetrations

The thickness of fire protection material at and adjacent to web penetrations shall be the greatest of that required, when:

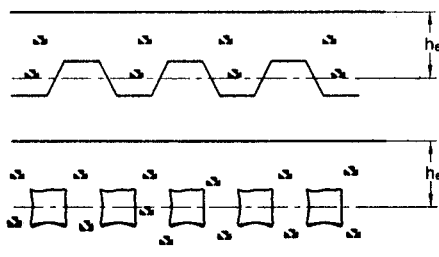
- area above the penetration is considered as a three-sided fire exposure condition ( $k_{sm1}$ ) (see Fig. 26),
- area below the penetration is considered as a four-sided fire exposure condition ( $k_{sm2}$ ) (see Fig. 26), and

- c) section as a whole is considered as a three-sided fire exposure condition ( $k_{sm}$ ) (see Fig. 26).

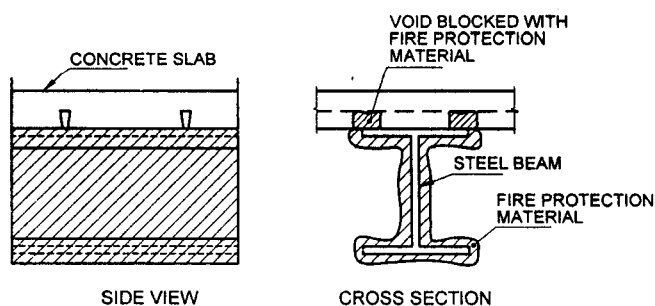
This thickness shall be applied over the full beam depth and shall extend on each side of the penetration for a distance at least equal to the beam depth and not less than 300 mm.

**16.11 Fire Resistance Rating**

The fire resistance rating of various building components such as walls, columns, beams, and floors are given in Table 31 and Table 32. Fire damage assessment of various structural elements of the building and adequacy of the structural repairs can be done by the fire resistance rating for encased steel column and beam (Table 31 and Table 32).



25A Effective Thickness



25B Blocking of Rib Voids

FIG. 25 THREE SIDED FIRE EXPOSURE CONDITION REQUIREMENTS

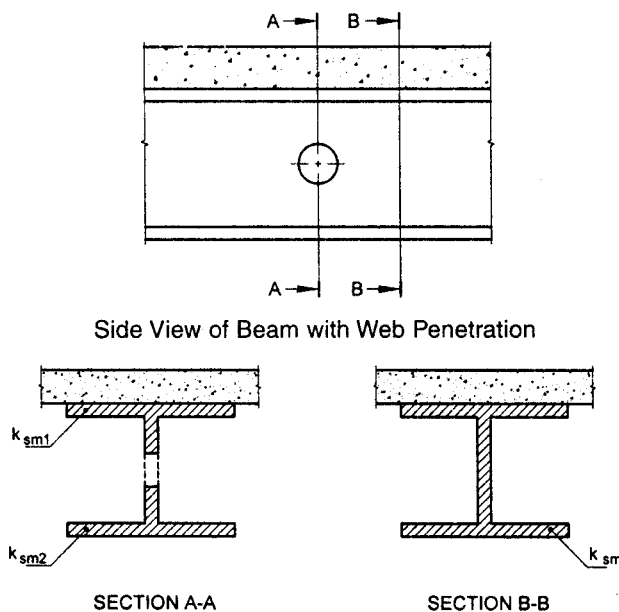


FIG. 26 WEB PENETRATION



**Table 31 Encased Steel Columns, 203 mm × 203 mm**  
**(Protection Applied on Four Sides)**  
*(Clause 16.11)*

SI No.	Nature of Construction and Materials	Minimum Dimensions Excluding Any Finish, for a Fire Resistance of mm				
		1 h	1 ½ h	2 h	3 h	4 h
(1)	(2)	(3)	(4)	(5)	(6)	(7)
i)	Hollow protection (without an air cavity over the flanges):					
a)	Metal lathing with trowelled lightweight aggregate gypsum plaster <sup>1)</sup>	13	15	20	32	—
b)	Plasterboard with 1.6 mm wire binding at 100 mm pitch, finished with lightweight aggregate gypsum plaster less than the thickness specified:					
1)	9.5 mm plaster board	10	15	—	—	—
2)	19 mm plaster board	10	13	20	—	—
c)	Asbestos insulating boards, thickness of board:					
1)	Single thickness of board, with 6 mm cover fillets at transverse joints	—	19	25	—	—
2)	Two layers, of total thickness	—	—	—	38	50
d)	Solid bricks of clay, composition or sand lime, reinforced in every horizontal joint, unplastered	50	50	50	75	100
e)	Aerated concrete blocks	60	60	60	—	—
f)	Solid blocks of lightweight concrete hollow protection (with an air cavity over the flanges)	50	50	50	60	75
ii)	Asbestos insulating board screwed to 25 mm asbestos battens	12	19	—	—	—
iii)	Solid protections					
a)	Concrete, not leaner than 1:2:4 mix (unplastered):					
1)	Concrete not assumed to be load bearing, reinforced <sup>2)</sup>	25	25	25	50	75
2)	Concrete assumed to be load bearing	50	50	50	75	75
b)	Lightweight concrete, not leaner than 1 : 2 : 4 mix (unplastered) concrete not assumed to be load bearing, reinforced <sup>2)</sup>	25	25	25	25	25

<sup>1)</sup> So fixed or designed, as to allow full penetration for mechanical bond.

<sup>2)</sup> Reinforcement shall consist of steel binding wire not less than 2.3 mm diameter, or a steel mesh weighing not less than 0.5 kg/m<sup>2</sup>. In concrete protection, the spacing of the reinforcement shall not exceed 200 mm in any direction.

## SECTION 17 FABRICATION AND ERECTION

### 17.1 General

Tolerances for fabrication of steel structures shall conform to IS 7215. Tolerances for erection of steel structures shall conform to IS 12843. For general guidance on fabrication by welding, reference may be made to IS 9595.

### 17.2 Fabrication Procedures

#### 17.2.1 Straightening

Material shall be straightened or formed to the specified configuration by methods that will not reduce the properties of the material below the values used in design. Local application of pressure at room or at elevated temperature or other thermal means may be used for straightening, provided the above is satisfied.

#### 17.2.2 Clearances

The erection clearance for cleated ends of members,

connecting steel to steel should preferably be not greater than 2.0 mm at each end. The erection clearance at ends of beams without web cleats should be not more than 3 mm at each end. Where for practical reasons, greater clearance is necessary, suitably designed seating should be provided.

**17.2.2.1** In bearing type of connections, the holes may be made not more than 1.5 mm greater than the diameter of the bolts in case of bolts of diameter less than 25 mm and not more than 2 mm in case of bolts of diameter more than 25 mm, unless otherwise specified by the engineer. The hole diameter in base plates shall not exceed the anchor bolt diameter by more than 6 mm.

**17.2.2.2** In friction type of connection clearance may be maintained, unless specified otherwise in the design document.

#### 17.2.3 Cutting

Cutting shall be effected by sawing, shearing, cropping, machining or thermal cutting process. Shearing,

**Table 32 Encased Steel Beams, 406 mm × 176 mm  
(Protection Applied on Three Sides)  
(Clause 16.11)**

SI No.	Nature of Construction and Materials	Minimum Thickness of Protection for a Fire Resistance of					
		mm					
(1)	(2)	½ h (3)	1 h (4)	1½ h (5)	2 h (6)	3 h (7)	4 h (8)
i)	Hollow protection (without an air cavity beneath the lower flanges):						
a)	Metal lathing with trowelled lightweight aggregate gypsum plaster <sup>1)</sup>	13	13	15	20	25	—
b)	Plasterboard with 1.6 mm wire binding at 100 mm pitch, finished with lightweight aggregate gypsum plaster less than the thickness specified <sup>2)</sup>						
1)	9.5 mm plaster board	10	10	15	—	—	—
2)	19 mm plaster board	10	10	13	20	—	—
c)	Asbestos insulating boards, thickness of board:						
1)	Single thickness of board, with 6 mm cover fillets at transverse joints	—	—	19	25	—	—
2)	Two layers, of total thickness	—	—	—	—	38	50
ii)	Hollow protection (with an air cavity below the lower flange)						
a)	Asbestos insulating board screwed to 25 mm asbestos battens	9	12	—	—	—	—
iii)	Solid protections						
a)	Concrete, not leaner than 1:2:4 mix (unplastered):						
1)	Concrete not assumed to be load bearing, reinforced <sup>3)</sup>	25	25	25	25	50	75
2)	Concrete assumed to be load bearing	50	50	50	50	75	75
b)	Lightweight concrete, not leaner than 1:2:4 mix (unplastered) <sup>4)</sup>	25	25	25	25	40	60

<sup>1)</sup> So fixed or designed, as to allow full penetration for mechanical bond.

<sup>2)</sup> Where wire binding cannot be used, expert advice should be sought regarding alternative methods of support to enable the lower edges of the plasterboard to be fixed together and to the lower flange, and for the top edge of the plasterboard to be held in position.

<sup>3)</sup> Reinforcement shall consist of steel binding wire not less than 2.3 mm in diameter, or a steel mesh weighing not less than 0.5 kg/m<sup>2</sup>. In concrete protection, the spacing of the reinforcement shall not exceed 200 mm in any direction.

<sup>4)</sup> Concrete not assumed to be load bearing, reinforced.

cropping and gas cutting shall be clean, reasonably square, and free from any distortion. Should the inspector find it necessary, the edges shall be ground after cutting. Planning or finishing of sheared or gas-cut edges of plates or shapes shall not be required, unless specially noted on drawing or included in stipulated edge preparation for welding or when specifically required in the following section.

Re-entrant corners shall be free from notches and shall have largest practical radii with a minimum radius of 15 mm.

#### 17.2.3.1 Shearing

Shearing of items over 16 mm thick to be galvanized and subject to tensile force or bending moment shall not be carried out, unless the item is stress relieved subsequently.

The use of sheared edges in the tension area shall be avoided in location subject to plastic hinge rotation at factored loading.

#### 17.2.3.2 Thermal cutting

Gas cutting of high tensile steel by mechanically controlled torch may be permitted, provided special care is taken to leave sufficient metal to be removed

by machining, so that all metal that has been hardened by flame is removed. Hand flame cutting may be permitted only subject to the approval of the inspecting authority.

Except where the material is subsequently joined by welding, no load shall be transmitted through a gas cut surface.

Thermally cut free edges, which shall be subject to calculated static tensile stress shall be free from round bottom gouges greater than 5 mm deep. Gouges greater than 5 mm deep and notches shall be removed by grinding.

#### 17.2.4 Holing

**17.2.4.1** Holes through more than one thickness of material for members, such as compound stanchion and girder flanges, shall be where possible, drilled after the members are assembled and tightly clamped or bolted together. A round hole for a bolt shall either be machine flame cut, or drilled full size, or sub-punched 3 mm undersize and reamed to size or punched full size.

Hand flame cutting of a bolt hole shall not be permitted except as a site rectification measure for holes in column base plates.

#### 17.2.4.2 *Punching*

A punched hole shall be permitted only in material whose yield stress ( $f_y$ ) does not exceed 360 MPa and where thickness does not exceed  $(5600/f_y)$  mm. In cyclically loaded details, punching shall be avoided in plates with thickness greater than 12 mm.

For greater thickness and cyclically loaded details, holes shall be either drilled from the solid or sub-punched or sub-drilled and reamed.

The die for all sub-punched holes or the drill for all sub-drilled holes shall be at least 3 mm smaller than the required diameter of finished hole.

#### 17.2.4.3 *Oversize holes*

A special plate washer of minimum thickness 4 mm shall be used under the nut, if the hole diameter is larger than the bolt diameter by 3 mm or more.

Oversize hole shall not exceed  $1.25d$  or  $(d+8)$  mm in diameter, where  $d$  is the nominal bolt diameter, in mm.

A short slotted hole shall not exceed the appropriate hole size in width and  $1.33d$  in length. A long slotted hole shall not exceed the appropriate hole size in width and  $2.5d$  in length. If the slot length is larger than those specified, shear transfer in the direction of slot is not admissible even in friction type of connection.

Slotted holes shall be punched either in one operation or else formed by punching or drilling two round holes apart and completed by high quality mechanically controlled flame cutting and dressing to ensure that bolt can freely travel the full length of the slot.

#### 17.2.4.4 *Fitted bolt holes*

Holes for turned and fitted bolts shall be drilled to a diameter equal to the nominal diameter of the shank or barrel subject to tolerance specified in IS 919 (Parts 1 and 2). Preferably, parts to be connected with close tolerance or barrel bolts shall be firmly held together by tacking bolts or clamps and the holes drilled through all the thicknesses at one operation and subsequently reamed to size. All holes not drilled through all thicknesses at one operation shall be drilled to a smaller size and reamed out after assembly. Where this is not practicable, the parts shall be drilled and reamed separately through hard bushed steel jigs.

17.2.4.5 Holes for rivets or bolts shall not be formed generally by gas cutting process. However, advanced gas cutting processes such as plasma cutting may be used to make holes in statically loaded members only. In cyclically loaded members subjected to tensile stresses which are vulnerable under fatigue, gas cutting shall not be used unless subsequent reaming is done to remove the material in the heat affected zone around the hole.

### 17.3 *Assembly*

All parts of bolted members shall be pinned or bolted and rigidly held together during assembly.

The component parts shall be assembled and aligned in such a manner that they are neither twisted nor otherwise damaged, and shall be so prepared that the specified camber, if any, is provided.

#### 17.3.1 *Holes in Assembly*

When holes are drilled in one operation through two or more separable parts, these parts, when so specified by the engineer, shall be separated after drilling and the burrs removed.

Matching holes for rivets and black bolts shall register with each other so that a gauge of 1.5 mm or 2.0 mm (as the case may be, depending on whether the diameter of the rivet or bolt is less than or more than 25 mm) less in diameter than the diameter of the hole will pass freely through the assembled members in the direction at right angle to such members.

Drilling done during assembly to align holes shall not distort the metal or enlarge the holes.

Holes in adjacent part shall match sufficiently well to permit easy entry of bolts. If necessary, holes except oversize or slotted holes may be enlarged to admit bolts, by moderate amount of reaming.

#### 17.3.2 *Thread Length*

When design is based on bolts with unthreaded shanks in the shear plane, appropriate measures shall be specified to ensure that, after allowing for tolerance, neither the threads nor the thread run-out be in the shear plane.

The length of bolt shall be such that at least one clear thread shows above the nut and at least one thread plus the thread run out is clear beneath the nut after tightening. One washer shall be provided under the rotated part.

#### 17.3.3 *Assembly Subjected to Vibration*

When non-preloaded bolts are used in a structure subject to vibration, the nuts shall be secured by locking devices or other mechanical means. The nuts of preloaded bolts may be assumed to be sufficiently secured by the normal tightening procedure.

#### 17.3.4 *Washers*

Washers are not normally required on non-preloaded bolts, unless specified otherwise. Tapered washers shall be used where the surface is inclined at more than  $3^\circ$  to a plane perpendicular to the bolt axis.

Hardened washer shall be used for preloaded bolts or the nut, whichever is to be rotated.

All material within the grip of the bolt shall be steel and no compressible material shall be permitted in the grip.

#### 17.4 Riveting

**17.4.1** Rivets shall be heated uniformly throughout their length, without burning or excessive scaling, and shall be of sufficient length to provide a head of standard dimensions. These shall, when driven, completely fill the holes and, if countersunk, the countersinking shall be fully filled by the rivet. If required, any protrusion of the countersunk head shall be dressed off flush.

**17.4.2** Riveted member shall have all parts firmly drawn and held together before and during riveting, and special care shall be taken in this respect for all single-riveted connections. For multiple riveted connections, a service bolt shall be provided in every third or fourth hole.

**17.4.3** Wherever practicable, machine riveting shall be carried out by using machines of the steady pressure type.

**17.4.4** All loose, burned or otherwise defective rivets shall be cut out and replaced before the structure is loaded, and special care shall be taken to inspect all single riveted connections.

**17.4.5** Special care shall be taken in heating and driving long rivets.

#### 17.5 Bolting

**17.5.1** In all cases where the full bearing area of the bolt is to be developed, the bolt shall be provided with a washer of sufficient thickness under the nut to avoid any threaded portion of the bolt being within the thickness or the parts bolted together, unless accounted for in design.

**17.5.2** Pre-tensioned bolts shall be subjected to initial tension (the proof stress) by an appropriate pre-calibrated method.

#### 17.6 Welding

**17.6.1** Welding shall be in accordance with IS 816, IS 819, IS 1024, IS 1261, IS 1323 and IS 9595, as appropriate.

**17.6.2** For welding of any particular type of joint, welders shall give evidence acceptable to the purchaser of having satisfactorily completed appropriate tests as prescribed in IS 817, IS 1393, IS 7307 (Part 1), IS 7310 (Part 1) and IS 7318 (Part 1), as relevant.

**17.6.3** Assembly and welding shall be carried out in such a way to minimize distortion and residual stress

and that the final dimensions are within appropriate tolerances.

#### 17.7 Machining of Butts, Caps and Bases

**17.7.1** Column splices and butt joints of struts and compression members, depending on contact for stress transmission, shall be accurately machined and close-butted over the whole section with a clearance not exceeding 0.2 mm locally, at any place. Sum of all such clearance shall not be more than 30 percent of the contact area for stress transmission. In column caps and bases, the ends of shafts together with the attached gussets, angles, channels, etc; after connecting together should be accurately machined so that clearance between the contact surfaces shall not exceed 2 mm locally, subject further to the condition that sum total of all such clearance shall not exceed 30 percent of the total contact area for stress transmission. Care should be taken that these gussets, connecting angles or channels are fixed with such accuracy that they are not reduced in thickness by machining by more than 2.0 mm.

**17.7.2** Where sufficient gussets and rivets or welds are provided to transmit the entire loading (*see* Section 4), the column ends need not be machined.

#### 17.7.3 Slab Bases and Caps

Slab bases and slab caps, except when cut from material with true surfaces, shall be accurately machined over the bearing surfaces and shall be in effective contact with the end of the stanchion, the bearing face which is to be grouted to fit tightly at both top and bottom, unless welds are provided to transmit the entire column face.

**17.7.4** To facilitate grouting, sufficient gap shall be left between the base plates and top of pedestal and holes shall be provided where necessary in stanchion bases for the escape of air.

#### 17.8 Painting

**17.8.1** Painting shall be done in accordance with IS 1477 (Parts 1 and 2).

**17.8.2** All surfaces, which are to be painted, oiled or otherwise treated, shall be dry and thoroughly cleaned to remove all loose scale and loose rust.

**17.8.3** Shop contact surfaces need not be painted unless specified. If so specified, they shall be brought together while the paint is still wet.

**17.8.4** Surfaces not in contact, but inaccessible after shop assembly, shall receive the full specified protective treatment before assembly. This does not apply to the interior of sealed hollow sections.

**17.8.5** Chequered plates shall be painted but the details of painting shall be specified by the purchaser.

**17.8.6** In case of surfaces to be welded, the steel shall not be painted or metal coated within a suitable distance of any edge to be welded, if the paint specified or the metal coating is likely to be harmful to welders or impair the quality of the welds.

**17.8.7** Welds and adjacent parent metal shall not be painted prior to de-slagging, inspection and approval.

**17.8.8** Parts to be encased in concrete shall not be painted or oiled.

**17.8.9** Contact surface in friction type connection shall not be painted in advance.

### **17.9 Marking**

Each piece of steel work shall be distinctly marked before dispatch, in accordance with a marking diagram and shall bear such other marks as will facilitate erection.

### **17.10 Shop Erection**

**17.10.1** The steel work shall be temporarily shop erected complete or as arranged with the inspection agency so that accuracy of fit may be checked before dispatch. The parts shall be shop assembled with sufficient numbers of parallel drifts to bring and keep the parts in place.

**17.10.2** In the case of parts drilled or punched, through steel jigs with bushes resulting in all similar parts being interchangeable, the steelwork may be shop erected in such position as arranged with the inspection agency.

**17.10.3** In case of shop fabrication using numerically controlled machine data generated by computer software (like CAD), the shop erection may be dispensed with at the discretion of the inspector.

### **17.11 Packing**

All projecting plates or bars and all ends of members at joints shall be stiffened, all straight bars and plates shall be bundled, all screwed ends and machined surfaces shall be suitably packed and all rivets, bolts, nuts, washers and small and loose parts shall be packed separately in cases, so as to prevent damage or distortion during transit.

### **17.12 Inspection and Testing**

**17.12.1** The inspecting authority shall have free access at all reasonable times to those parts of the manufacturer's works which are concerned with the fabrication of the steelwork and shall be afforded all reasonable facilities for satisfying himself that the

fabrication is being undertaken in accordance with the provisions of this standard.

**17.12.2** Unless specified otherwise, inspection shall be made at the place of manufacture prior to dispatch and shall be conducted so as not to interfere unnecessarily with the operation of the work.

**17.12.3** The manufacturer shall guarantee compliance with the provisions of this standard, if required to do so by the purchaser.

**17.12.4** Should any structure or part of a structure be found not to comply with any of the provisions of this standard, it shall be liable to rejection. No structure or part of the structure, once rejected shall be resubmitted for test, except in cases where the purchaser or his authorized representative considers the defect as rectifiable.

**17.12.5** Defects, which may appear during fabrication, shall be made good with the consent of and according to the procedure laid down by the inspecting authority.

**17.12.6** All gauges and templates necessary to satisfy the inspection authority shall be supplied by the manufacturer. The inspecting authority may, at his discretion, check the test results obtained at the manufacturer's works by independent testing at outside laboratory, and should the material so tested be found to be unsatisfactory, the cost of such tests shall be borne by the manufacturer, and if found satisfactory, the cost shall be borne by the purchaser.

### **17.13 Site Erection**

#### **17.13.1 Plant and Equipment**

The suitability and capacity of all plant and equipment used for erection shall be to the satisfaction of the engineer.

#### **17.13.2 Storing and Handling**

All structural steel should be so stored and handled at the site that the members are not subjected to excessive stresses and damage by corrosion due to exposure to environment.

#### **17.13.3 Setting Out**

The positioning and levelling of all steelwork, the plumbing of stanchions and the placing of every part of the structure with accuracy shall be in accordance with the approved drawings and to the satisfaction of the engineer in accordance with the deviation permitted below.

##### **17.13.3.1 Erection tolerances**

Unloaded steel structure, as erected, shall satisfy the criteria specified in Table 33 within the specified tolerance limits.

Each criterion given in the table shall be considered as a separate requirement, to be satisfied independent of any other tolerance criteria. The erection tolerances specified in Table 33 apply to the following reference points:

- a) For a column, the actual centre point of the column at each floor level and at the base, excluding any base-plate or cap-plate. The level of the base plate on pedestal shall be so as to avoid contact with soil and corrosive environment; and
- b) For a beam, the actual centre point of the top surface at each end of the beam, excluding any end-plate.

**Table 33 Normal Tolerances After Erection**

SI No.	Criterion	Permitted Deviation
(1)	(2)	(3)
i)	Deviation of distance between adjacent columns	5 mm
ii)	Inclination of a column in a multi-storey building between adjacent floor levels	$0.002h_s$ where, $h_s$ is the storey height
iii)	Deviation of location of a column in a multi-storey building at any floor level from a vertical line through the intended location of the column base	$0.003 \sum h_b/n^{0.5}$ where, $\sum h_b$ is the total height from the base to the floor level concerned and $n$ is the number of storeys from the base to the floor level concerned
iv)	Inclination of a column in a single storey building, (not supporting a crane gantry) other than a portal frame	$0.003 5h_c$ where, $h_c$ is the height of the column
v)	Inclination of the column of a portal frame (not supporting a crane gantry)	Mean: $0.002h_c$ Individual: $0.010h_c$ where $h_c$ is the height of the column

The straightness tolerances specified in Table 34 have been assumed in the derivation of the design stress for the relevant type of member. Where the curvature exceeds these values, the effect of additional curvature on the design calculations shall be reviewed.

A tension member shall not deviate from its correct position relative to the members to which it is connected by more than 3 mm along any setting axis.

#### 17.13.4 Safety During Fabrication and Erection

**17.13.4.1** All steel materials including fabricated structures, either at fabrication shop or at erection site, shall be handled only by a worker skilled in such jobs; where necessary with load tested lifting devices, having

tested wire rope slings of correct size. The devices should be well maintained and operated by experienced operators.

**Table 34 Straightness Tolerances Incorporated in Design Rules**  
(Clause 7.13.3.1)

SI No.	Criterion	Permitted Deviation
(1)	(2)	(3)
i)	Straightness of a column (or other compression member) between points which will be laterally restrained on completion of erection	$0.001L$ generally, and $0.002L$ for members with hollow cross-sections; where, $L$ is the length between points which will be laterally restrained
ii)	Straightness of a compression flange of a beam, relative to the weak axis, between points, which will be laterally restrained on completion of erection.	$0.001L$ generally, and $0.002L$ for members with hollow cross-sections; where, $L$ is the length between points which will be laterally restrained

**17.13.4.2** Oxygen and acetylene cylinders and their hoses shall have distinctive colours. Cylinders should be stored in upright position in well-ventilated rooms or in open air, not exposed to flames, naked lights or extreme heat and should also be in upright position when they are being used. All gas cutting works shall be done only by experienced skilled gas cutters, equipped with gloves, boots, aprons, goggles and good cutting sets of approved make.

**17.13.4.3** While doing any welding work, it should be ensured that the welding machine is earthed and the welding cables are free from damage. The welder and his assistant shall use a face shield or head shield with a welding lens and clear cover glass and their hands, legs and bodies shall be well protected by leather gloves, shoes and aprons. Combustible materials should be kept away from the sparks and globules of molten metals generated in any arc welding. In case of welding in a confined place, it should be provided with an exhaust system to take care of the harmful gases, fumes and dusts generated.

**17.13.4.4** In addition to precautions against all the hazards mentioned above, erection workers shall also be protected in the following manner:

- a) All workers shall wear helmets and shall also be provided with gloves and shoes. In addition those working at heights shall use safety belts.
- b) All structures shall be so braced/guyed during erection that there is no possibility of collapse before erection work is completed.
- c) Warning signs such as 'Danger', 'Caution',

'440 volts', 'Do not smoke', 'Look ahead', etc; should be displayed at appropriate places.

**17.13.4.5** For detailed safety precautions during erection, reference shall be made to IS 7205.

#### **17.13.5 Field Connections**

##### **17.13.5.1 Field riveting**

Rivets driven at the site shall be heated and driven with the same care as those driven in the shop.

##### **17.13.5.2 Field bolting**

Field bolting shall be carried out with the same care as required for shop bolting.

##### **17.13.5.3 Fillet welding**

Field assembly and welding shall be executed in accordance with the requirements for shop fabrications excepting such as manifestly apply to shop conditions only. Where the steel has been delivered painted, the paint shall be removed for a distance of at least 50 mm on either side of the joint.

#### **17.14 Painting After Erection**

**17.14.1** Before painting of such steel which is delivered unpainted is commenced, all surfaces to be painted shall be dry and thoroughly cleaned from all loose scale and rust, as required by the surface protection specification.

**17.14.2** The specified protective treatment shall be completed after erection. All rivet and bolt heads and the site welds after de-slagging shall be cleaned. Damaged or deteriorated paint surfaces shall first be made good with the same type of paint as the shop coat. Where specified, surfaces which will be in contact after site assembly, shall receive a coat of paint (in addition to any shop priming) and shall be brought together while the paint is still wet. No painting shall be used on contact surfaces in the friction connection, unless specified otherwise by the design document.

**17.14.3** Where the steel has received a metal coating in the shop, this coating shall be completed on site so as to be continuous over any welds and site rivets or bolts, subject to the approval of the engineer. Painting on site may complete protection. Bolts, which have been galvanized or similarly treated, are exempted from this requirement.

**17.14.4** Surface, which will be inaccessible after site assembly, shall receive the full-specified protective treatment before assembly.

**17.14.5** Site painting should not be done in frosty or foggy weather, or when humidity is such as to cause condensation on the surfaces to be painted.

#### **17.15 Bedding Requirement**

**17.15.1** Bedding shall be carried out with Portland cement grout or mortar, as described under **17.15.4** or fine cement concrete in accordance with IS 456.

**17.15.2** For multi-storeyed buildings, this operation shall not be carried out until a sufficient number of bottom lengths of stanchions have been properly lined, leveled and plumbed and sufficient floor beams are in position.

**17.15.3** Whatever method is employed, the operation shall not be carried out until the steelwork has been finally levelled and plumbed, stanchion bases being supported meanwhile by steel wedges or nuts; and immediately before grouting, the space under the steel shall be thoroughly cleaned.

**17.15.4** Bedding of structure shall be carried out with grout or mortar, which shall be of adequate strength and shall completely fill the space to be grouted and shall either be placed under pressure or by ramming against fixed supports. The grouts or mortar used shall be non-shrinking variety.

#### **17.16 Steelwork Tenders and Contracts**

A few recommendations are given in Annex G for general information.

## ANNEX A

(Clause 1.1)

## LIST OF REFERRED INDIAN STANDARDS

IS No.	Title	IS No.	Title
456 : 2000	Plain and reinforced concrete — Code of practice ( <i>fourth revision</i> )	1030 : 1998	Carbon steel castings for general engineering purposes ( <i>fifth revision</i> )
513 : 1994	Cold-rolled low carbon steel sheets and strips ( <i>fourth revision</i> )	1079 : 1994	Hot rolled carbon steel sheets and strips — Specification ( <i>fifth revision</i> )
801 : 1975	Code of practice for use of cold-formed light gauge steel structural members in general building construction ( <i>first revision</i> )	1148 : 1982	Specification for hot-rolled rivet bars (up to 40 mm diameter) for structural purposes ( <i>third revision</i> )
808 : 1989	Dimensions for hot-rolled steel beam, column, channel and angle sections ( <i>third revision</i> )	1149 : 1982	High tensile steel rivet bars for structural purposes ( <i>third revision</i> )
813 : 1986	Scheme of symbols for welding	1261 : 1959	Code of practice for seam welding in mild steel
814 : 2004	Covered electrodes for manual metal arc welding of carbon and carbon manganese steel — Specification ( <i>sixth revision</i> )	1278 : 1972	Specification for filler rods and wires for gas welding ( <i>second revision</i> )
816 : 1969	Code of practice for use of metal arc welding for general construction in mild steel ( <i>first revision</i> )	1323 : 1982	Code of practice for oxy-acetylene welding for structural work in mild steels ( <i>second revision</i> )
817	Training of welders — Code of practice:	1363	Hexagon head bolts, screws and nuts of product grade C:
(Part 1) : 1992	Manual metal arc welding ( <i>second revision</i> )	(Part 1) : 2002/ ISO 4016:1999	Hexagon head bolts (size range M5 to M64) ( <i>fourth revision</i> )
(Part 2) : 1996	Oxyfuel welding ( <i>second revision</i> )	(Part 2) : 2002/ ISO 4018:1999	Hexagon head screws (size range M5 to M64) ( <i>fourth revision</i> )
819 : 1957	Code of practice for resistance spot welding for light assemblies in mild steel	(Part 3) : 1992/ ISO 4034:1986	Hexagon nuts (size range M5 to M64) ( <i>third revision</i> )
875	Code of practice for design loads (other than earthquake) for buildings and structures:	1364	Hexagon head bolts, screws and nuts of product grades A and B:
(Part 1) : 1987	Dead loads – unit weights of building materials and stored materials ( <i>second revision</i> )	(Part 1) : 2002/ ISO 4014:1999	Hexagon head bolts (size range M1.6 to M64) ( <i>fourth revision</i> )
(Part 2) : 1987	Imposed loads ( <i>second revision</i> )	(Part 2) : 2002/ ISO 4017:1999	Hexagon head screws (size range M1.6 to M64) ( <i>fourth revision</i> )
(Part 3) : 1987	Wind loads ( <i>second revision</i> )	(Part 3) : 2002/ ISO 4032:1999	Hexagon nuts, style 1 (size range M1.6 to M64) ( <i>fourth revision</i> )
(Part 4) : 1987	Snow loads ( <i>second revision</i> )	(Part 4) : 2003/ ISO 4035:1999	Hexagon thin nuts (chamfered) (size range M1.6 to M64) ( <i>fourth revision</i> )
(Part 5) : 1987	Special loads and load combinations ( <i>second revision</i> )	(Part 5) : 2002/ ISO 4036:1999	Hexagon thin nuts — Product grade B (unchamfered) (size range M1.6 to M10) ( <i>fourth revision</i> )
919	ISO systems of limits and fits:	1367	Technical supply conditions for threaded steel fasteners:
(Part 1) : 1993/ ISO 286-1:1988	Bases of tolerance, deviations and fits ( <i>second revision</i> )	(Part 1) : 2002/ ISO 8992:1986	General requirements for bolts, screws and studs ( <i>third revision</i> )
(Part 2) : 1993/ ISO 286-2:1988	Tables of standard tolerance grades and limit deviations for holes and shafts ( <i>first revision</i> )	(Part 2) : 2002/ ISO 4759-1:2000	Tolerances for fasteners — Bolts, screws, studs and nuts — Product grades A, B and C ( <i>third revision</i> )
962 : 1989	Code of practice for architectural and building drawings ( <i>second revision</i> )	(Part 3) : 2002/ ISO 898-1:1999	Mechanical properties of fasteners made of carbon steel and alloy steel — bolts, screws and studs ( <i>fourth revision</i> )
1024 : 1999	Code of practice for use of welding in bridges and structures subject to dynamic loading ( <i>second revision</i> )		



<i>IS No.</i>	<i>Title</i>	<i>IS No.</i>	<i>Title</i>
(Part 5) : 2002/ ISO 898-5:1998	Mechanical properties of fasteners made of carbon steel and alloy steel – set screws and similar threaded fasteners not under tensile stresses ( <i>third revision</i> )	1477	Code of practice for painting of ferrous metals in buildings:
(Part 6) : 1994/ ISO 898-2:1992	Mechanical properties and test methods for nuts with specified proof loads ( <i>third revision</i> )	(Part 1) : 1971 (Part 2) : 1971 1608 : 2005/ ISO 6892:1998	Pre-treatment ( <i>first revision</i> ) Painting ( <i>first revision</i> ) Metallic materials — Tensile testing at ambient temperatures ( <i>third revision</i> )
(Part 7) : 1980	Mechanical properties and test methods for nuts without specified proof loads ( <i>second revision</i> )	1641 : 1988	Code of practice for fire safety of buildings (general): General principles of fire grading and classification ( <i>first revision</i> )
(Part 8) : 2002/ ISO 2320:1997	Prevailing torque type steel hexagon nuts — Mechanical and performance properties ( <i>third revision</i> )	1642 : 1989	Code of practice for fire safety of buildings (general): Details of construction ( <i>first revision</i> )
(Part 9)	Surface discontinuities	1643 : 1988	Code of practice for fire safety of buildings (general): Exposure hazard ( <i>first revision</i> )
Sec 1:1993/ ISO 6157-1:1988	Bolts, screws and studs for general application ( <i>third revision</i> )	1852 : 1985	Rolling and cutting tolerance for hot rolled steel products ( <i>fourth revision</i> )
Sec 2:1993/ ISO 6157-3:1988	Bolts, screws and studs for special applications ( <i>third revision</i> )	1875 : 1992	Specification for carbon steel billets, blooms, slabs and bars for forgings ( <i>fifth revision</i> )
(Part 10):2002/ ISO 6157-2:1995	Surface discontinuities — Nuts ( <i>third revision</i> )	1893	Criteria for earthquake resistant design of structures: Part 1 General provisions and buildings
(Part 11):2002/ ISO 4042:1999	Electroplated coatings ( <i>third revision</i> )	(Part 1) : 2002	Specification for hot forged steel rivets for hot closing (12 to 36 mm diameter) ( <i>first revision</i> )
(Part 12):1981	Phosphate coatings on threaded fasteners ( <i>second revision</i> )	1929 : 1982	Steel rivet and stay bars for boilers ( <i>first revision</i> )
(Part 13):1983	Hot dip galvanized coatings on threaded fasteners ( <i>second revision</i> )	1990 : 1973	Steel plates for pressure vessels for intermediate and high temperature service including boilers ( <i>second revision</i> )
(Part 14)	Mechanical properties of corrosion-resistant stainless-steel fasteners.	2002 : 1992	Hot rolled low, medium and high tensile structural steel ( <i>sixth revision</i> )
Sec 1 : 2002/ ISO 3506-1:1997	Bolts, screws and studs ( <i>third revision</i> )	2062 : 2006	Specification for cold forged solid steel rivets for hot closing (6 to 16 mm diameter) ( <i>first revision</i> )
Sec 2 : 2002/ ISO 3506-2:1997	Nuts ( <i>third revision</i> )	2155 : 1982	1.5 percent manganese steel castings for general engineering purpose ( <i>third revision</i> )
Sec 3 : 2002/ ISO 3506-3:1997	Set screws and similar fasteners not under tensile stress ( <i>third revision</i> )	2708 : 1993	Structural steel for construction of hulls of ships ( <i>second revision</i> )
(Part 16) : 2002/ ISO 8991:1986	Designation system for fasteners ( <i>third revision</i> )	3039 : 1988	Acceptance tests for wire flux combination for submerged arc welding ( <i>first revision</i> )
(Part 17) : 1996/ ISO 3269:1988	Inspection, sampling and acceptance procedure ( <i>third revision</i> )	3613 : 1974	Specification for hexagon fit bolts ( <i>first revision</i> )
(Part 18) : 1996	Packaging ( <i>third revision</i> )	3757 : 1985	Specification for high strength structural bolts ( <i>second revision</i> )
(Part 19) : 1997/ ISO 3800:1993	Axial load fatigue testing of bolts, screws and studs	4000 : 1992	Code of practice for high strength bolts in steel structures ( <i>first revision</i> )
(Part 20) : 1996/ ISO 898-7:1992	Torsional test and minimum torques for bolts and screws with nominal diameters 1 mm to 10 mm	4326 : 1993	Code of practice for earthquake resistance design and construction of buildings ( <i>second revision</i> )
1387 : 1993	General requirements for the supply of metallurgical materials ( <i>second revision</i> )		
1393 : 1961	Code of practice for training and testing of oxy-acetylene welders		
1395 : 1982	Low and medium alloy steel covered electrodes for manual metal arc welding ( <i>third revision</i> )		

<i>IS No.</i>	<i>Title</i>	<i>IS No.</i>	<i>Title</i>
5369 : 1975	General requirements for plain washers and lock washers ( <i>first revision</i> )	(Part 1) : 1974	Part 1 Fusion welding of steel
5370 : 1969	Specification for plain washers with outside diameter $\approx 3 \times$ inside diameter	7318 (Part 1) : 1974	Approval test for welders when welding procedure approval is not required: Part 1 Fusion welding of steel
5372 : 1975	Taper washers for channels (ISMC) ( <i>first revision</i> )	7557 : 1982	Specification for steel wire (upto 20 mm) for the manufacture of cold forged rivets ( <i>first revision</i> )
5374 : 1975	Taper washers for I-beams (ISMB) ( <i>first revision</i> )	8000	Geometrical tolerancing on technical drawings:
5624 : 1993	Foundation bolts — Specification ( <i>first revision</i> )	(Part 1) : 1985/	Tolerances of form, orientation, location and run-out, and appropriate geometrical definitions ( <i>first revision</i> )
6240 : 1999	Hot rolled steel plate (upto 6 mm) sheet and strip for the manufacture of low pressure liquefiable gas cylinders — Specification ( <i>third revision</i> )	ISO 1101 : 1983	
6419 : 1996	Welding rods and bare electrodes for gas shielded arc welding of structural steel ( <i>first revision</i> )	(Part 2) : 1992/	Maximum material principles ( <i>first revision</i> )
6560 : 1996	Molybdenum and chromium-molybdenum low alloy steel welding rods and bare electrodes for gas shielded arc welding ( <i>first revision</i> )	ISO 2692 : 1988	Dimensioning and tolerancing of profiles ( <i>second revision</i> )
6610 : 1972	Specification for heavy washers for steel structures	(Part 3) : 1992/	Practical examples of indications on drawings
6623 : 2004	High strength structural nuts — Specification ( <i>first revision</i> )	ISO 1660 : 1987	Guide for preparation and arrangement of sets of drawings and parts lists
6639 : 1972	Specification for hexagonal bolts for steel structures	(Part 4) : 1976	Code of practice for corrosion protection of steel reinforcement in RB and RCC construction
6649 : 1985	Specification for hardened and tempered washers for high strength structural bolts and nuts ( <i>first revision</i> )	8976 : 1978	Recommended design practice for corrosion prevention of steel structures
7205 : 1974	Safety code for erection of structural steelwork	9077 : 1979	Steel tubes for idlers for belt conveyors ( <i>first revision</i> )
7215 : 1974	Specification for tolerances for fabrication of steel structures	9172 : 1979	Metal arc welding of carbon and carbon manganese steels — Recommendations ( <i>first revision</i> )
7280 : 1974	Specification for bare wire electrodes for submerged arc welding of structural steels	9295 : 1983	Hot-rolled steel strip for welded tubes and pipes — Specification ( <i>second revision</i> )
7307	Approval tests for welding procedures:	9595 : 1996	Tolerances for erection of steel structures
(Part 1) : 1974	Part 1 Fusion welding of steel	10748 : 2004	Handbook for Structural Engineers — Structural Steel Sections
7310	Approval tests for welders working to approved welding procedures	12843 : 1989	
		SP 6 (1) : 1964	

**ANNEX B**  
 [Clause 4.1.1(c)]  
**ANALYSIS AND DESIGN METHODS**

**B-1 ADVANCED STRUCTURAL ANALYSIS AND DESIGN****B-1.1 Analysis**

For a frame, comprising members of compact section with full lateral restraint, an advanced structural analysis may be carried out, provided the analysis can be shown to accurately model the actual behaviour of that class of frames. The analysis shall take into account the relevant material properties, residual stresses, geometrical imperfections, reduction in stiffness due to axial compression, second-order effects, section strength and ductility, erection procedures and interaction with the foundations.

Advanced structural analysis for earthquake loads shall take into account, as appropriate the response history, torsional response, pounding against adjacent structures, and strain rate effects.

**B-1.2 Design**

For the strength limit state, it shall be sufficient to satisfy the section capacity requirements of Section 8 for the members subjected to bending, of Section 7 for axial members, of Section 9 for combined forces and of Section 10 for connections. Effect of moment magnification given in Section 9, instability given in Section 7 and lateral buckling given in Section 8 need not be considered while designing the member, since advanced analysis methods directly consider these.

An advanced structural analysis for earthquake loads shall recognize that the design basis earthquake loads calculated in accordance with IS 1893 is assumed to correspond to the load at which the first significant plastic hinge forms in the structure.

**B-2 SECOND ORDER ELASTIC ANALYSIS AND DESIGN****B-2.1 Analysis**

In a second-order elastic analysis, the members shall be assumed to remain elastic, and changes in frame geometry under the design load and changes in the effective stiffness of the members due to axial forces shall be accounted for. In a frame where the elastic buckling load factor ( $\lambda_{cr}$ ) of the frame as determined in accordance with 4.6 is greater than 5, the changes in the effective stiffness of the members due to axial forces may be neglected.

**B-2.2 Design Bending Moment**

The design bending moment under factored load shall be taken as the maximum bending moment in the length of the member. It shall be determined either:

- a) directly from the second-order analysis; or
- b) approximately, if the member is divided into a sufficient number of elements, as the greatest of the element end bending moments; or
- c) by amplifying the calculated design bending moment, taken as the maximum bending moment along the length of a member as obtained by superposition of the simple beam bending moments determined by the analysis.

For a member with zero axial force or a member subject to axial tension, the factored design bending moment shall be calculated as the moment obtained from second order analysis without any amplification.

For a member with a design axial compressive force as determined from the analysis, the factored design bending moment shall be calculated as follows:

$$M = \delta_b M_m$$

where

$\delta_b$  = moment amplification factor for a braced member determined in accordance with Section 9.

**B-3 FRAME INSTABILITY ANALYSIS****B-3.1 Analysis**

Frame instability, as treated here, is related to the design of multi-storey rigid-jointed frames subject to side sway. The elastic critical load factor,  $\lambda_{cr}$  may be determined using the deflection method as given in B-3.2 or any other recognized method. This is used to calculate the amplified sway moments for elastic designs and to check frame stability in plastic designs. The elastic critical load factor,  $\lambda_{cr}$  of a frame is the ratio by which each of the factored loads would have to be increased to cause elastic instability.

**B-3.2 Deflection Method**

An accurate method of analysis (ordinary linear elastic analysis) should be used to determine the horizontal deflections of the frame due to horizontal forces applied at each floor level, which is equal to the notional horizontal load in 4.3.6. Allowance should be made

for the degree of rigidity of the base as given in B-3.2 in this deflection calculation.

The base stiffness should be determined by reference to 4.3.4.

The elastic critical load factor,  $\lambda_{cr}$  is calculated as:

$$\lambda_{cr} = \frac{1}{200\phi_{s,Max}}$$

where

$\phi_{s,Max}$  = largest value of the sway index,  $\phi_s$  given by:

$$\phi_s = \frac{\delta_u - \delta_L}{h}$$

where

$h$  = storey height,

$\delta_u$  = horizontal deflection of the top of the storey due to the combined gravity and notional loads, and

$\delta_L$  = horizontal deflection of the bottom of the storey due to gravity and notional load.

### B-3.3 Partial Sway Bracing

In any storey the stiffening effect of infill wall panels may be allowed for by introducing a diagonal strut in

that storey of area  $A$ , given by:

$$A = \frac{k_3 \sum K_c}{h(h/b)} \left[ 1 + (h/b)^2 \right]^{3/2}$$

where

$h$  = storey height;

$b$  = width of the braced bay;

$\sum K_c$  = sum of the stiffness  $I/L$ , of the columns in that storey;

$$k_3 = \frac{h^2 \sum S_p}{80E \sum K_c} \leq 2; \text{ and}$$

$\sum S_p$  = sum of spring stiffness horizontal force per unit horizontal deflection of all the panels in that storey determined from:

$$S_p = \frac{0.6h/b}{\left[ 1 + (h/b)^2 \right]^2} t_p E_p$$

where

$t_p$  = thickness of the wall panel, and

$E_p$  = modulus of elasticity of the panel material.

## ANNEX C

[Clauses 5.2.2.2(b) and 5.6.2]

### DESIGN AGAINST FLOOR VIBRATION

#### C-1 GENERAL

Floor with longer spans of lighter construction and less inherent damping are vulnerable to vibrations under normal human activity. Natural frequency of the floor system corresponding to the lowest mode of vibration, damping characteristics, are important characteristics in floor vibration. Open web steel joists (trusses) or steel beams on the concrete deck may experience walking vibration problem. Fatigue, overloading of floor systems and vibrations due to rhythmic activities such as aerobic or dance classes are not within the scope of this Annex.

#### C-2 ANNOYANCE CRITERIA

In the frequency range of 2 to 8 Hz in which people are most sensitive to vibration, the threshold level

corresponds approximately to 0.5 percent  $g$ , where  $g$  is the acceleration due to gravity. Continuous vibration is generally more annoying than decaying vibration due to damping. Floor systems with the natural frequency less than 8 Hz in the case of floors supporting rhythmic activity and 5 Hz in the case of floors supporting normal human activity should be avoided.

#### C-3 FLOOR FREQUENCY

The fundamental natural frequency can be estimated by assuming full composite action, even in non-composite construction. This frequency,  $f_1$  for a simply supported one way system is given by

$$f_1 = 156 \sqrt{EI_T / WL^4}$$

where

- $E$  = modulus of elasticity of steel, MPa;  
 $I_T$  = transformed moment of inertia of the one way system (in terms of equivalent steel) assuming the concrete flange of width equal to the spacing of the beam to be effective, in mm<sup>4</sup>;  
 $L$  = span length, in mm; and  
 $W$  = dead load of the one way joist, in N/mm.

If the one way joist system is supported by a flexible beam running perpendicular with the natural frequency  $f_2$ , the floor frequency may be reduced to  $f_r$ , given by:

$$\frac{1}{f_r^2} = \frac{1}{f_1^2} + \frac{1}{f_2^2}$$

#### C-4 DAMPING

The percentage of critical damping may be assumed approximately as given below:

Sl No.	System	Critical Damping Percent
(1)	(2)	(3)
i)	Fully composite construction	2
ii)	Bare steel beam and concrete deck	3-4
iii)	Floor with finishes, false ceiling, fire proofing, ducts furniture	6
iv)	Partitions not located along a support or not spaced farther apart than 6 m and partitions oriented in orthogonal directions	Up to 12

#### C-5 ACCELERATION

The peak acceleration  $a_o$ , from heel impact for floors of spans greater than 7m and natural frequency  $f_1$ , less than 10 Hz may be calculated as:

$$a_o/g = 600 f_1 / W$$

where

- $W$  = total weight of floors plus contents over the span length and equivalent floor width ( $b$ ), in N;  
 $b$  =  $40t_s$  ( $20t_s$  when over hang is only on one side of the beam);  
 $t_s$  = equivalent thickness of the slab, averaging concrete in slab and ribs; and  
 $g$  = acceleration due to gravity.

## ANNEX D

(Clause 7.2.2)

### DETERMINATION OF EFFECTIVE LENGTH OF COLUMNS

#### D-1 METHOD FOR DETERMINING EFFECTIVE LENGTH OF COLUMNS IN FRAMES

In the absence of a more exact analysis, the effective length of columns in framed structures may be obtained by multiplying the actual length of the column between the centres of laterally supporting members (beams) given in Fig. 27 and Fig. 28 with the effective length factor  $K$ , calculated by using the equations given below, provided the connection between beam and column is rigid type:

a) *Non-sway Frames (Braced Frame)* [(see 4.1.2(a))]

A frame is designated as non-sway frame if the relative displacement between the two adjacent floors is restrained by bracings or shear walls (see 4.1.2). The effective length factor,  $K$ , of column in non-sway frames is given by (see Fig. 27):

$$K = \frac{[1 + 0.145(\beta_1 + \beta_2) - 0.265\beta_1\beta_2]}{[2 - 0.364(\beta_1 + \beta_2) - 0.247\beta_1\beta_2]}$$

b) *Sway Frames (Moment Resisting Frames)* [see 4.1.2(b)]

The effective length factor  $K$ , of column in sway frames is given by (see Fig. 28):

$$K = \left[ \frac{1 - 0.2(\beta_1 + \beta_2) - 0.12\beta_1\beta_2}{1 - 0.8(\beta_1 + \beta_2) + 0.6\beta_1\beta_2} \right]^{0.5}$$

where

$$\beta_1, \beta_2 \text{ are given, } \beta = \frac{\sum K}{\sum K_c + \sum K_b}$$

$K_c, K_b$  = effective flexural stiffness of the columns and beams meeting at the joint at the ends of the columns and rigidly connected at the joints, and these are calculated by:

$$K = C (I / L)$$

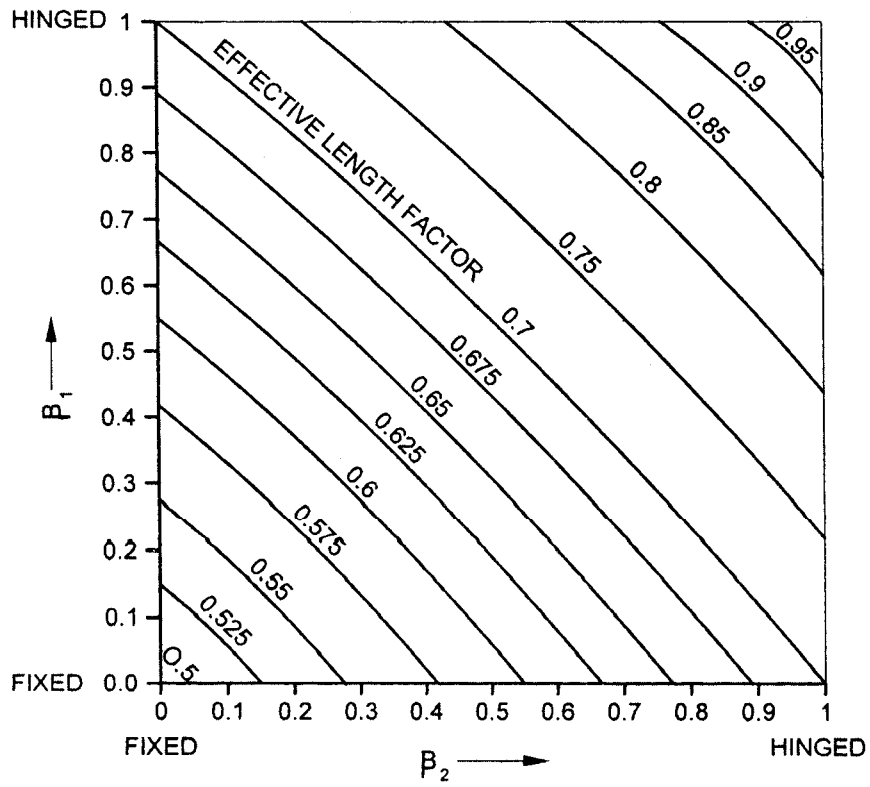


FIG. 27 COLUMN EFFECTIVE LENGTH FACTOR — NON-SWAY FRAME

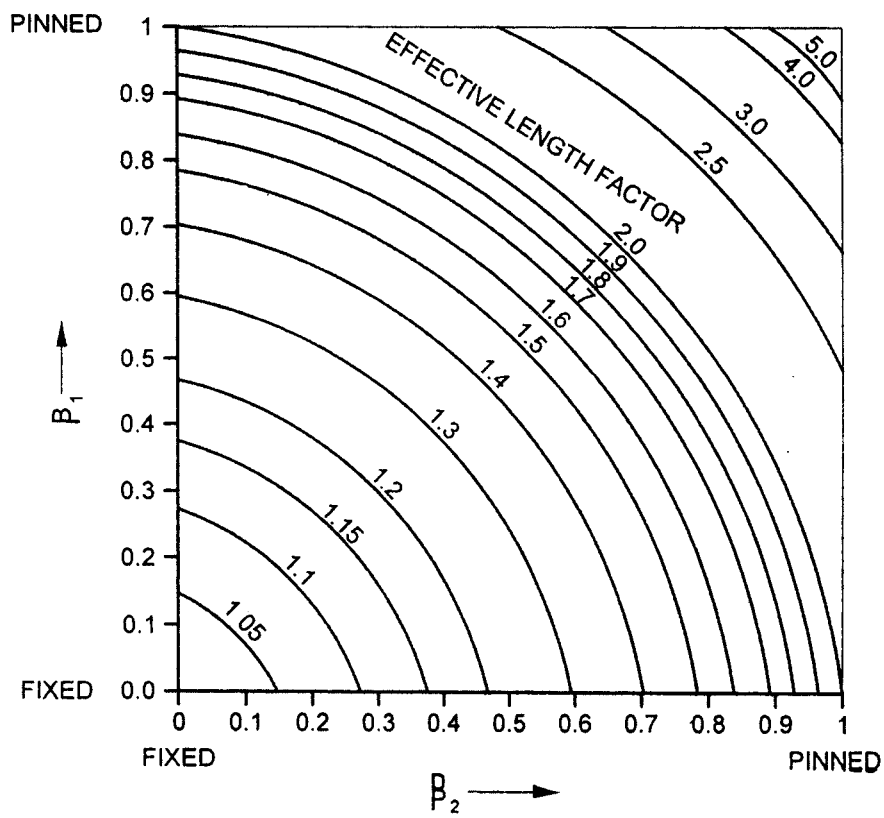


FIG. 28 COLUMN EFFECTIVE LENGTH FACTOR — SWAY FRAME

$I$  = moment of inertia of the member about an axis perpendicular to the plan of the frame.

$L$  = length of the member equal to centre-to-centre distance of the intersecting member.

$C$  = correction factor as shown in Table 35.

**Table 35 Correction Factors for Effective Flexural Stiffness**

Sl No.	Far End Condition (2)	Correction Factor, C	
		Braced Frame (3)	Unbraced Frame (4)
i)	Pinned	$1.5(1 - \bar{n})$	$1.5(1 - \bar{n})$
ii)	Rigidly connected to column	$1.0(1 - \bar{n})$	$1.0(1 - 0.2\bar{n})$
iii)	Fixed	$2.0(1 - 0.4\bar{n})$	$0.67(1 - 0.4\bar{n})$

NOTE —  $\bar{n} = \frac{P}{P_c}$

where  
 $P_c$  = elastic buckling load, and  
 $P$  = applied load.

**D-2 METHOD FOR DETERMINING EFFECTIVE LENGTH FOR STEPPED COLUMNS (see 7.2.2)**

**D-2.1 Single Stepped Columns**

Effective length in the plane of stepping (bending about axis z-z) for bottom and top parts for single stepped column shall be taken as given in Table 36.

NOTE — The provisions of D-2.1 are applicable to intermediate columns as well with stepping on either side, provided appropriate values of  $I_1$  and  $I_2$  are taken.

**D-3 EFFECTIVE LENGTH FOR DOUBLE STEPPED COLUMNS**

Effective lengths in the plane of steppings (bending about axis z-z) for bottom, middle and top parts for a double stepped column shall be taken as follows (see also Fig. 29):

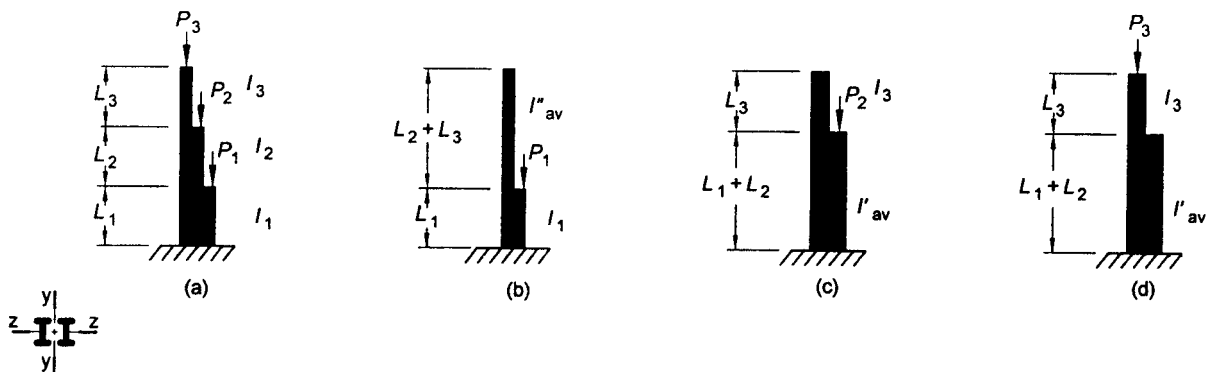


FIG. 29 EFFECTIVE LENGTH OF DOUBLE STEPPED COLUMNS

Coefficient  $K_1$  for effective length of bottom part of double stepped column shall be taken from the formula:

$$K_1 = \sqrt{\frac{t_1 K_1^2 + (t_2 K_2^2 + K_3^2) \times (1 + n_2)^2 \times \frac{I_1}{I'_{av}}}{1 + t_1 + t_2}}$$

where

$K_1, K_2,$  and  $K_3$  are taken from Table 41.

$$t_1 = \frac{P_1}{P_3}, \quad t_2 = \frac{P_2}{P_3}, \quad n_2 = \frac{L_2}{L_1}$$

$I'_{av}$  = average value of moment of inertia for the lower and middle parts

$$= \frac{I_1 L_1 + I_2 L_2}{L_1 + L_2}$$

$I''_{av}$  = average value of moment of inertia for the middle and top parts

$$= \frac{I_2 L_2 + I_3 L_3}{L_2 + L_3}$$

Value of coefficient  $K_2$  for middle part of column is given by formula:

$$K_2 = \frac{K_1}{C_2}, \text{ and}$$

coefficient  $K_3$  for the top part of the column is given by:

$$K_3 = \frac{K_1}{C_3} \leq 3$$

where

$$C_2 = \frac{L_2}{L_1} \sqrt{\frac{I_1 (P_2 + P_3)}{I_2 (P_1 + P_2 + P_3)}}, \quad C_3 = \frac{L_3}{L_1} \sqrt{\frac{I_1 P_3}{I_3 (P_1 + P_2 + P_3)}}$$

NOTE — The provisions of D-3 are applicable to intermediate columns as well with steppings on either side, provided appropriate values of  $I_1, I_2$  and  $I_3$  are taken.

**Table 36 Effective Length of Single Stepped Columns**  
(Clause D-2.1)

Sl No.	Degree of End Restraint	Sketch	Effective Length Coefficients	Column Parameters for All Cases
(1)	(2)	(3)	(4)	(5)
i)	Effectively held in position and restrained against rotation at both ends		$K_1 = \sqrt{\frac{K_{12}^2 + K_{11}^2 (\alpha - 1)}{\alpha}}$ $K_2 = \frac{K_1}{C_1} \leq 3$ <p>where</p> $K_{12} \text{ and } K_{11} \text{ are to be taken as per Table 37}$	
ii)	Effectively held in position at both ends and restrained against rotation at bottom end only		$K_1 = \sqrt{\frac{K_{12}^2 + K_{11}^2 (\alpha - 1)}{\alpha}}$ $K_2 = \frac{K_1}{C_1} \leq 3$ <p>where</p> $K_{12} \text{ and } K_{11} \text{ are to be taken as per Table 38}$	$\alpha = \frac{P_1 + P_2}{P_2}$ $C_1 = \frac{L_2}{L_1} \sqrt{\frac{I_1}{I_2 \alpha}}$ $\frac{i_2}{i_1} = \frac{I_2}{L_2} \times \frac{L_1}{I_1}$
iii)	Effectively held in position and restrained against rotation at bottom end, and top end held against rotation but not held in position		$K_2 = \frac{K_1}{C_1} \leq 3$ <p><math>K_1</math> to be taken as per Table 39</p>	<p>Effective length of bottom part of column in plane of stepping = <math>K_1 L_1</math></p>
iv)	Effectively held in position and restrained against rotation at bottom end, and top end neither held against rotation nor held in position		$K_1 \text{ to be taken as per Table 40}$ $K_2 = \frac{K_1}{C_1} \leq 3$	<p>Effective length of top part of column in plane of stepping = <math>K_2 L_2</math></p>

**Table 37 Coefficients of Effective Lengths  $K_{12}$  and  $K_{11}$  for Columns with Both Ends Effectively Held in Position and Restrained Against Rotation**  
(Table 36)

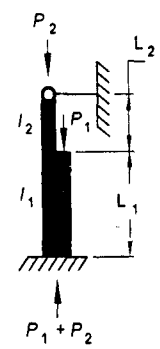
$I_2/I_1$	Coefficients $K_{12}$ and $K_{11}$ for $L_2/L_1$ Equal to														
	0.1	0.2	0.3	0.4	0.5	0.6	0.7	0.8	0.9	1.0	1.2	1.4	1.6	1.8	2.0
Coefficient $K_{12}$ ( $P_1 = 0$ )															
0.05	0.74	0.94	1.38	1.60	1.87	2.07	2.23	2.39	2.52	2.67	3.03	3.44	3.85	4.34	4.77
0.1	0.67	0.76	1.00	1.20	1.42	1.61	1.78	1.92	2.04	2.20	2.40	2.60	2.86	3.18	3.41
0.2	0.64	0.70	0.79	0.93	1.07	1.23	1.41	1.50	1.60	1.72	1.92	2.11	2.28	2.45	2.64
0.3	0.62	0.68	0.74	0.85	0.95	1.06	1.18	1.28	1.39	1.48	1.67	1.82	1.96	2.12	2.20
0.4	0.60	0.66	0.71	0.77	0.82	0.93	0.99	1.08	1.17	1.23	1.39	1.53	1.66	1.79	1.92
0.5	0.59	0.65	0.70	0.77	0.82	0.93	0.99	1.08	1.17	1.23	1.39	1.53	1.66	1.79	1.92
1.0	0.55	0.60	0.65	0.70	0.75	0.80	0.85	0.90	0.95	1.00	1.10	1.20	1.30	1.40	1.50
Coefficient $K_{11}$ ( $P_2 = 0$ )															
0.05	0.65	0.67	0.71	0.85	1.01	1.17	1.31	1.41	1.50	1.57	1.67	1.74	1.78	1.82	1.86
0.1	0.64	0.65	0.65	0.65	0.78	0.92	1.05	1.15	1.25	1.33	1.45	1.55	1.62	1.68	1.71
0.2	0.62	0.64	0.65	0.65	0.66	0.73	0.83	0.92	1.01	1.09	1.23	1.33	1.41	1.48	1.54
0.3	0.60	0.63	0.64	0.65	0.66	0.67	0.73	0.81	0.89	0.94	1.09	1.20	1.28	1.35	1.41
0.4	0.58	0.63	0.63	0.64	0.64	0.66	0.68	0.75	0.82	0.88	1.01	1.10	1.19	1.26	1.32
0.5	0.57	0.61	0.63	0.64	0.64	0.65	0.68	0.72	0.77	0.83	0.94	1.04	1.12	1.19	1.25
1.0	0.55	0.58	0.60	0.61	0.62	0.63	0.65	0.67	0.70	0.73	0.80	0.88	0.93	1.01	1.05

NOTE — Intermediate value may be obtained by interpolation.



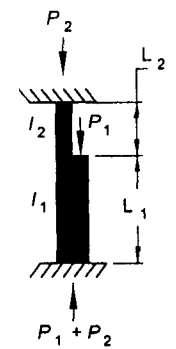
**Table 38 Coefficients of Effective Lengths  $K_{12}$  and  $K_{11}$  for Columns with Both Ends Effectively Held in Position and Restrained Against Rotation at Bottom End Only**  
(Table 36)

Coefficients $K_{12}$ and $K_{11}$ for $L_2/L_1$ Equal to															
$I_2/I_1$	0.1	0.2	0.3	0.4	0.5	0.6	0.7	0.8	0.9	1.0	1.2	1.4	1.6	1.8	2.0
Coefficient $K_{12}$ ( $P_1 = 0$ )															
0.05	0.97	1.66	2.10	2.43	2.72	2.92	3.08	3.24	3.48	3.73	4.22	4.85	5.36	6.00	6.58
0.1	0.83	1.21	1.57	1.95	2.14	2.33	2.46	2.60	2.76	2.91	3.28	3.61	4.03	4.43	4.85
0.3	0.78	0.90	1.09	1.27	1.44	1.60	1.74	1.86	1.98	2.11	2.35	2.51	2.76	2.99	3.25
0.5	0.78	0.86	0.99	1.10	1.22	1.35	1.47	1.57	1.67	1.76	1.96	2.15	2.34	2.50	2.76
1.0	0.78	0.85	0.92	0.99	1.06	1.13	1.20	1.27	1.34	1.41	1.54	1.68	1.82	1.97	2.10
Coefficient $K_{11}$ ( $P_2 = 0$ )															
0.05	0.67	0.67	0.82	1.16	1.35	1.48	1.58	1.65	1.69	1.74	1.81	1.84	1.86	1.88	1.90
0.1	0.67	0.67	0.73	0.93	1.11	1.25	1.36	1.45	1.52	1.57	1.66	1.72	1.77	1.80	1.82
0.3	0.67	0.67	0.67	0.71	0.80	0.90	0.99	1.08	1.15	1.22	1.33	1.41	1.48	1.54	1.59
0.5	0.67	0.67	0.67	0.69	0.73	0.81	0.87	0.94	1.01	1.07	1.17	1.26	1.33	1.39	1.44
1.0	0.67	0.67	0.67	0.68	0.71	0.74	0.78	0.82	0.87	0.91	0.99	1.07	1.13	1.19	1.24



**Table 39 Coefficients of Effective Lengths  $K_1$  for Columns Effectively Held in Position and Restrained Against Rotation at Bottom End and Top End Held Against Rotation but not Held in Position**  
(Table 36)

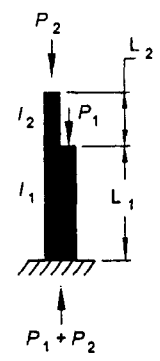
Coefficients $K_1$ for $I_2/I_1$ Equal to															
$C_1$	0.1	0.2	0.3	0.4	0.5	0.6	0.7	0.8	0.9	1.0	1.2	1.4	1.6	1.8	2.0
0	2.0	1.8	1.7	1.67	1.6	1.55	1.50	1.4	1.43	1.4	1.37	1.3	1.1	1.10	1.0
0.5	2.0	1.9	1.8	1.74	1.6	1.65	1.61	1.5	1.55	1.5	—	—	—	—	—
1.0	2.0	2.0	2.0	2.00	2.0	2.00	—	—	—	—	—	—	—	—	—
1.5	2.0	2.2	2.3	2.48	—	—	—	—	—	—	—	—	—	—	—
2.0	2.0	2.6	2.9	—	—	—	—	—	—	—	—	—	—	—	—
2.5	2.5	3.1	3.5	—	—	—	—	—	—	—	—	—	—	—	—
3.0	3.0	3.7	4.1	—	—	—	—	—	—	—	—	—	—	—	—



NOTE — Intermediate values may be obtained by interpolation.

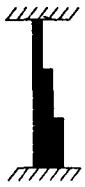

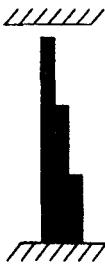
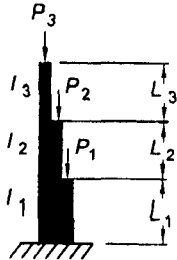

**Table 40 Coefficients of Effective Lengths  $K_1$  for Columns with Top Ends Free and Bottom End Effectively Held in Position and Restrained Against Rotation**  
(Table 36)

Coefficients $K_1$ for $I_2/I_1$ Equal to															
$C_1$	0.1	0.2	0.4	0.6	0.8	1.0	1.2	1.4	1.6	1.8	2.0	2.5	5.0	10	20
0	2.0	2.0	2.0	2.0	2.0	2.0	2.0	2.0	2.0	2.0	2.0	2.0	2.0	2.0	2.0
0.5	2.0	2.14	2.24	2.36	2.47	2.57	2.67	2.76	2.85	2.94	3.02	—	—	—	—
1.0	2.0	2.73	3.13	3.44	3.74	4.00	—	—	—	—	—	—	—	—	—
1.5	3.0	3.77	4.35	4.86	—	—	—	—	—	—	—	—	—	—	—
2.0	4.0	4.90	5.67	—	—	—	—	—	—	—	—	—	—	—	—
2.5	5.0	6.08	7.00	—	—	—	—	—	—	—	—	—	—	—	—
3.0	6.0	7.25	—	—	—	—	—	—	—	—	—	—	—	—	—



NOTE — Intermediate values may be obtained by interpolation.

**Table 41 Values of  $K_1$ ,  $K_2$  and  $K_3$**   
(Clause D-3)

Sl No.	Degree of End Restraint	Sketch	$K_1$	$K_2$	$K_3$	Column Parameters for All Cases
(1)	(2)	(3)	(4)	(5)	(6)	(7)
i)	Effectively held in position and restrained against rotation at both ends		$K_1 = K_{11}$ where $K_{11}$ is taken from Table 37	$K_2 = K_{11}$ where $K_{11}$ is taken from Table 37	$K_3 = K_{12}$ where $K_{12}$ is taken from Table 37	
ii)	Effectively held in position at both ends and restrained against rotation at bottom end only		$K_1 = K_{11}$ where $K_{11}$ is taken from Table 38	$K_2 = K_{11}$ where $K_{11}$ is taken from Table 38	$K_3 = K_{12}$ where $K_{12}$ is taken from Table 38	
iii)	Effectively held in position and restrained against rotation at bottom end, and top end held against rotation but not held in position		$K_1 = K_1$ where $K_1$ is taken from Table 39 with $C_1=0$	$K_2 = K_1$ where $K_1$ is taken from Table 39 with $C_1=0$	$K_3 = K_1$ where $K_1$ is taken from Table 39 with $C_1 = \frac{L_3}{L_1 + L_2} \sqrt{\frac{I_{3y}}{I_3}}$	
iv)	Effectively held in position and restrained against rotation at bottom end, and top end neither held against rotation nor against translation.		$K_1 = 2$	$K_2 = 2$	$K_3 = K_1$ where $K_1$ is taken from Table 40 with $C_1 = \frac{L_3}{L_1 + L_2} \sqrt{\frac{I_{3y}}{I_{31}}}$	

## ANNEX E

(Clause 8.2.2.1)

## ELASTIC LATERAL TORSIONAL BUCKLING

## E-1 ELASTIC CRITICAL MOMENT

## E-1.1 General

The elastic critical moment is affected by:

- Moment gradient in the unsupported length,
- Boundary conditions at the lateral support points,
- Non-symmetric and non-prismatic nature of the member, and
- Location of transverse load with respect to shear centre.

The boundary conditions at the lateral supports have two components:

- Torsional restraint* — Where the cross-section is prevented from rotation about the shear centre, and
- Warping restraint* — Where the flanges are prevented from rotating in their own plane about an axis perpendicular to the flange.

The elastic critical moment corresponding to lateral torsional buckling of a doubly symmetric prismatic beam subjected to uniform moment in the unsupported length and torsionally restraining lateral supports is given by:

$$M_{cr} = \frac{\pi^2 E I_y}{(L_{LT})^2} \left[ \frac{I_w}{I_y} + \frac{G I_t (L_{LT})^2}{\pi^2 E I_y} \right]^{0.5}$$

where

$I_y, I_w, I_t$  = moment of inertia about the minor axis, warping constant and St. Venants torsion constant of the cross-section, respectively;

$G$  = modulus of rigidity; and

$L_{LT}$  = effective length against lateral torsional buckling (see 8.3).

This equation in simplified form for I-section has been presented in 8.2.2.1.

While the simplified equation is generally on the safe side, there are many situations where this may be very conservative. More accurate calculation of the elastic critical moment for general case of unsymmetrical sections, loading away from shear centre and beams with moment gradient can be obtained from specialist literature, by using an appropriate computer programme or equations given below.

## E-1.2 Elastic Critical Moment of a Section Symmetrical About Minor Axis

In case of a beam which is symmetrical only about the minor axis, and bending about major axis, the elastic critical moment for lateral torsional buckling is given by the general equation:

$$M_{cr} = c_1 \frac{\pi^2 E I_y}{(L_{LT})^2} \left\{ \left[ \left( \frac{K}{K_w} \right)^2 \frac{I_w}{I_y} + \frac{G I_t (L_{LT})^2}{\pi^2 E I_y} + (c_2 y_g - c_3 y_j)^2 \right]^{0.5} - (c_2 y_g - c_3 y_j) \right\}$$

where

$c_1, c_2, c_3$  = factors depending upon the loading and end restraint conditions (see Table 42).

$K$  = effective length factors of the unsupported length accounting for boundary conditions at the end lateral supports. The effective length factor  $K$  varies from 0.5 for complete restraint against rotation about weak axis to 1.0 for free rotate about weak axis, with 0.7 for the case of one end fixed and other end free. It is analogous to the effective length factors for compression members with end rotational restraint.

$K_w$  = warping restraint factor. Unless special provisions to restrain warping of the section at the end lateral supports are made,  $K_w$  should be taken as 1.0.

$y_g$  =  $y$  distance between the point of application of the load and the shear centre of the cross-section and is positive when the load is acting towards the shear centre from the point of application.

$$y_j = y_s - 0.5 \int_A (z^2 - y^2) y dA / I_z$$

$y_s$  = co-ordinate of the shear centre with respect to centroid, positive when the shear centre is on the compression side of the centroid.

$y, z$  = co-ordinates of the elemental area with respect to centroid of the section.

$y_j$  = can be calculated by using the following approximation:

- a) *Plain flanges*  
 $y_j = 0.8 (2\beta_f - 1) h_y / 2.0$   
 (when  $\beta_f > 0.5$ )  
 $y_j = 1.0 (2\beta_f - 1) h_y / 2.0$   
 (when  $\beta_f \leq 0.5$ )
- b) *Lipped flanges*  
 $y_j = 0.8 (2\beta_f - 1) (1 + h_L/h) h_y / 2$   
 (when  $\beta_f > 0.5$ )  
 $y_j = (2\beta_f - 1) (1 + h_L/h) h_y / 2$   
 (when  $\beta_f \leq 0.5$ )
- where  
 $h_L$  = height of the lip,  
 $h$  = overall height of the section, and  
 $h_y$  = distance between shear centre of the two flanges of the cross-section.  
 $I_t$  = torsion constant, given by:  
 $= \sum b_i t_i^3 / 3$  for open section  
 $= 4A_e^2 / \sum (b/t)$  for hollow section

where

$A_e$  = area enclosed by the section, and  
 $b, t$  = breadth and thickness of the elements of the section, respectively.

$I_w$  = The warping constant, given by:

$(1 - \beta_f) \beta_f I_y h_y^2$  for I-sections mono-symmetric about weak axis

= 0 for angle, Tee, narrow rectangle section and approximately for hollow sections

$\beta_f = I_{fc} / (I_{fc} + I_{ft})$  where  $I_{fc}, I_{ft}$  are the moment of inertia of the compression and tension flanges, respectively, about the minor axis of the entire section.

**Table 42 Constants  $c_1, c_2$  and  $c_3$**   
 (Clause E-1.2)

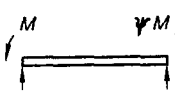








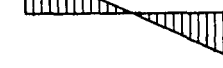
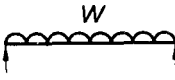

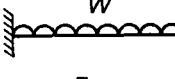

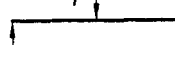

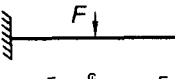

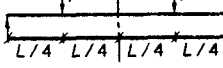

Loading and Support Conditions (1)	Bending Moment Diagram (2)	Value of $K$ (3)	Constants		
			$c_1$ (4)	$c_2$ (5)	$c_3$ (6)
	$\psi = +1$ 	1.0 0.7 0.5	1.000 1.000 1.000	—	1.000 1.113 1.144
	$\psi = +3/4$ 	1.0 0.7 0.5	1.141 1.270 1.305	—	0.998 1.565 2.283
	$\psi = +1/2$ 	1.0 0.7 0.5	1.323 1.473 1.514	—	0.992 1.556 2.271
	$\psi = +1/4$ 	1.0 0.7 0.5	1.563 1.739 1.788	—	0.977 1.531 2.235
	$\psi = 0$ 	1.0 0.7 0.5	1.879 2.092 2.150	—	0.939 1.473 2.150
	$\psi = -1/4$ 	1.0 0.7 0.5	2.281 2.538 2.609	—	0.855 1.340 1.957
	$\psi = -1/2$ 	1.0 0.7 0.5	2.704 3.009 3.093	—	0.676 1.059 1.546
	$\psi = -3/4$ 	1.0 0.7 0.5	2.927 3.009 3.093	—	0.366 0.575 0.837
	$\psi = -1$ 	1.0 0.7 0.5	2.752 3.063 3.149	—	0.000 0.000 0.000

Table 42 (Concluded)

Loading and Support Conditions	Bending Moment Diagram	Value of $K$	Constants		
			$c_1$ (4)	$c_2$ (5)	$c_3$ (6)
(1)	(2)	(3)			
		1.0 0.5	1.132 0.972	0.459 0.304	0.525 0.980
		1.0 0.5	1.285 0.712	1.562 0.652	0.753 1.070
		1.0 0.5	1.365 1.070	0.553 0.432	1.780 3.050
		1.0 0.5	1.565 0.938	1.257 0.715	2.640 4.800
		1.0 0.5	1.046 1.010	0.430 0.410	1.120 1.390

## ANNEX F

(Clause 10.6.1)

### CONNECTIONS

#### F-1 GENERAL

The requirement for the design of splice and beam to column connection as well as recommendation for their design shall be as given below.

#### F-2 BEAM SPLICES

**F-2.1** For rolled section beam splices located away from the point of maximum moment, it may be assumed that the flange splice carries all the moment and the web splice carries the shear (see Fig. 30). However in the case of a deep girder, the total moment may be divided between the flange and the web in accordance with the stress distribution. The web connection should then be designed to resist its share of moment and shear. Even web splice is designed to carry only shear force, the moment about the centroid of the bolt group on either side of the splice should be designed for moment due to eccentricity.

**F-2.2** Flange joints should preferably not be located at points of maximum stress. Where splice plates are used (see Fig. 30), their area shall not be less than 5 percent in excess of the area of the flange element spliced; and their centre of gravity shall coincide, as nearly as possible with that of the element spliced. There shall be enough fasteners on each side of the splice to develop the load in the element spliced plus 5 percent but in no case

should the strength developed be less than 50 percent of the effective strength of the material spliced. Wherever possible in welded construction, flange plates shall be joined by complete penetration butt welds. These butt welds shall develop the full strength of the plates. Whenever the flange width or thickness changes at the splice location, gradual transition shall be made in the width/thickness of the larger flange.

**F-2.3** When beam splice is located at the point of inflection of a continuous beam, the flange splicing requirement given above may be relaxed appropriately.

#### F-3 COLUMN SPLICE

**F-3.1** Where the ends of compression members are faced for bearing over the whole area, they shall be spliced to hold the connected parts aligned. The ends of compression members faced for bearing shall invariably be machined to ensure perfect contact of surfaces in bearing (see Fig. 31).

**F-3.2** Where such members are not faced for complete bearing the splices shall be designed to transmit all the forces to which the member is subjected at the splice location.

**F-3.3** Wherever possible, splices shall be proportioned and arranged so that centroidal axis of the splice

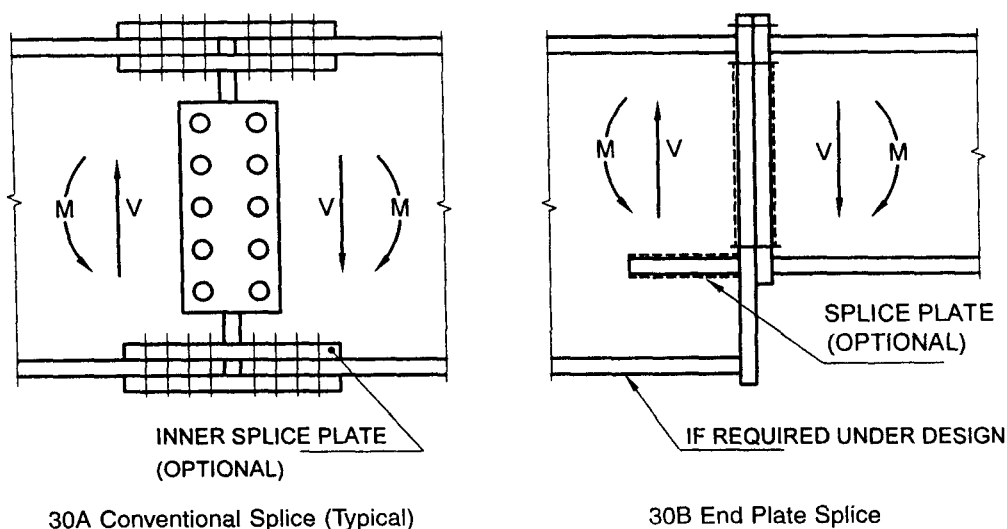


FIG. 30 BEAM SPLICES

coincides as nearly as possible with the centroidal axes of the members joined, in order to avoid eccentricity; but where eccentricity is present in the joint, the resulting stress considering eccentricity shall be provided for.

**F-3.4** If a column flange is subjected to significant tension or if the faces are not prepared for bearing, or if full continuity is required without slip, only HSFGB bolts shall be used.

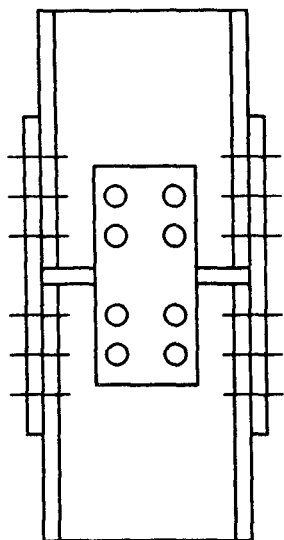


FIG. 31 COLUMN SPLICE (TYPICAL)

#### F-4 BEAM-TO-COLUMN CONNECTIONS

##### F-4.1 Simple Connections

Simple connections are assumed to transfer only shear at some nominal eccentricity and typically used in frames up to about five stories in height, where strength rather than stiffness govern the design. In such frames

separate lateral load resisting system is to be provided in the form of bracings or shear walls. The connections shown in Fig. 32 (A), (B), (C) and (D) can be assumed as simple connections in framed analysis and need to be checked only for the transfer of shear from beam to column.

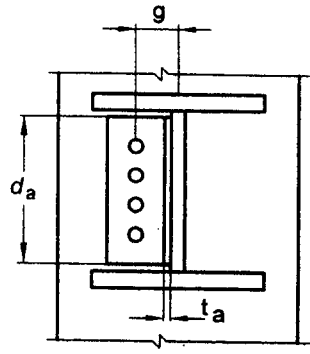
##### F-4.2 Rigid Connections

In high-rise and slender structures, stiffness requirements may warrant the use of rigid connections. Rigid connections transfer significant moments to the columns and are assumed to undergo negligible deformations at the joint. These are necessary in sway frames for stability and also contribute in resisting lateral loads. The connections shown in Fig. 32 (E), (F), (G) can be assumed as rigid connection in frame analysis and need to be checked for both shear and moment transfer from beam to the column. Fully welded connections can also be considered as rigid beam to column connections.

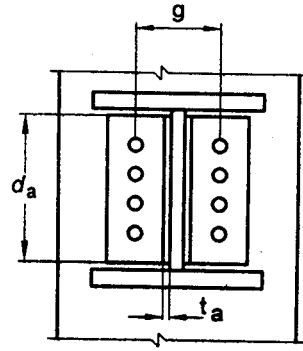
##### F-4.3 Semi-rigid Connections

Semi-rigid connections fall between the two types mentioned above. The fact is that simple connections do have some degree of rotational rigidity as in the semi-rigid connections. Similarly rigid connections do experience some degree of joint deformation and this can be utilised to reduce the joint design moments.

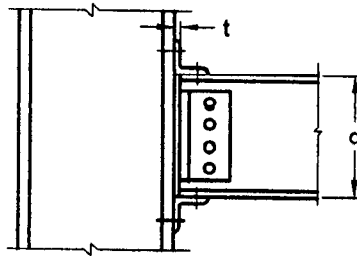
The moment-rotation relationship of the connections have to be determined based on experiments conducted for the specific design or based on the relationship derived from tests, presented in specialist literature. The simplest method of analysis will be to idealize the connection as an equivalent rotational spring with either a bilinear or non-linear moment-



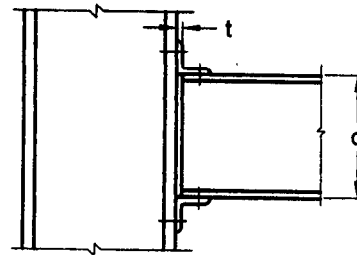
32A Single Web Angle



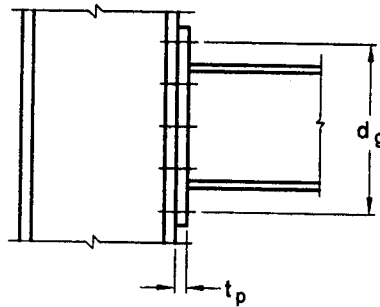
32B Double Web Angle



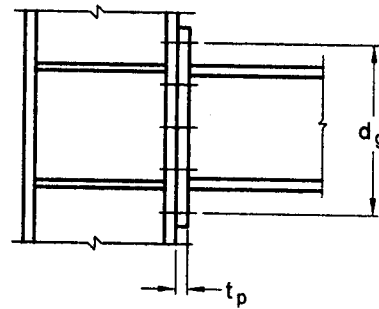
32C Top and Seat Angle with Double Web Angle



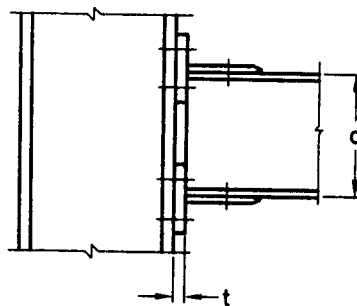
32D Top and Seat Angle without Double Web Angle



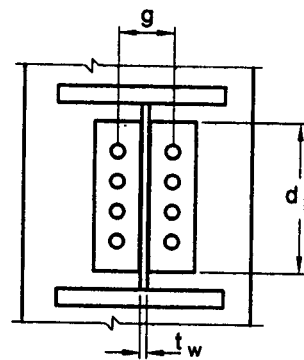
32E End Plate without Column Stiffeners



32F End Plate with Column Stiffeners



32G T-Stub



32H Header Plate

FIG. 32 SIZE PARAMETER FOR VARIOUS TYPES OF CONNECTION

rotation characteristics. The classification proposed by Bjorhovde combined with the Frey-Morris model can be used with convenience to model semi-rigid connections, as given in the next section.

**F-4.3.1 Connection Classification**

Connections are classified according to their ultimate strength or in terms of their initial elastic stiffness and Bjorhovde's classification. It is based on the non-dimensional moment parameter ( $m^1 = M_u / M_{pb}$ ) and the non-dimensional rotation ( $\theta^1 = \theta_r / \theta_p$ ) parameter, where  $\theta_p$  is the plastic rotation. The Bjorhovde's classification is based on a reference length of the beam equal to 5 times the depth of the beam. The limits used for connection classification are shown in Table 43 and are graphically represented in Fig. 33.

**F-4.3.2 Connection Models**

Frye-Morris has derived the following polynomial model for the moment curvature relationship of semi-rigid connections:

$$\theta_r = C_1(KM)^1 + C_2(KM)^3 + C_3(KM)^5$$

where

$M$  = moment at the joint, in kN m;

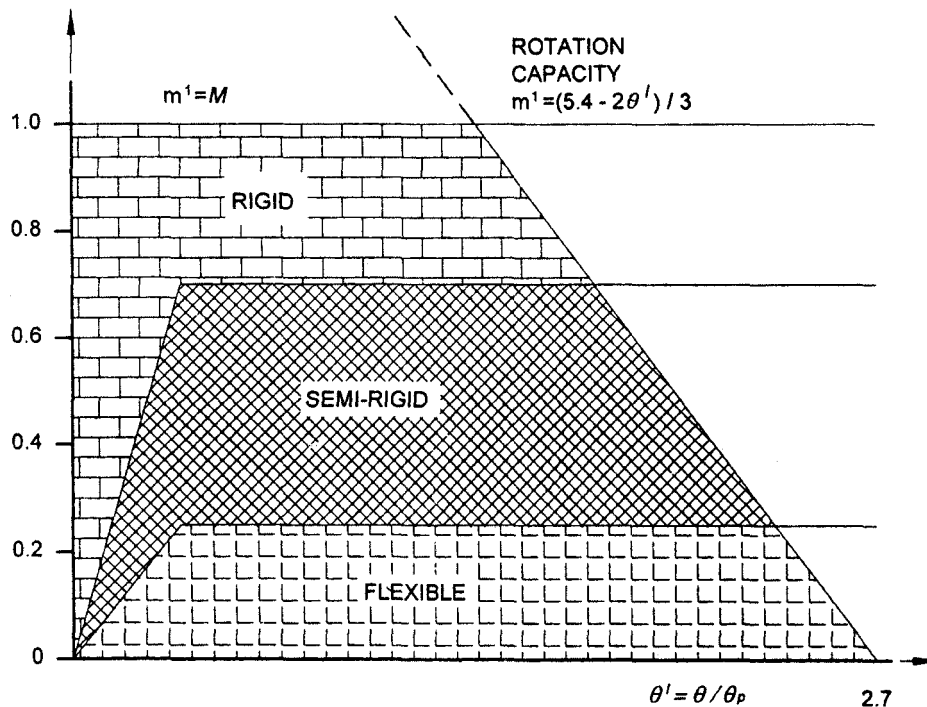
$K$  = standardization parameter which depend on the connection type and geometry; and

$C_1, C_2, C_3$  = curve fitting constants

Table 44 shows the curve fitting constants and standardization constants for Frye-Morris Model [All size parameters in the table are in mm (see Fig. 32)].

**Table 43 Connection Classification Limits**

Sl No.	Nature of the Connection	In Terms of Strength	In Terms of Stiffness
(1)	(2)	(3)	(4)
i)	Rigid connection	$m^1 \geq 0.7$	$m^1 \geq 2.5\theta^1$
ii)	Semi-rigid connection	$0.7 > m^1 > 0.2$	$2.5\theta^1 > m^1 > 0.5\theta^1$
iii)	Flexible connection	$m^1 \leq 0.2$	$m^1 \leq 0.5\theta^1$



**FIG. 33 CLASSIFICATION OF CONNECTIONS ACCORDING TO BJORHOVDE**



**Table 44 Connection Constants in Frye-Morris Model**  
(Clause F-4.3.2)

SI No.	Type	Connection Type	Curve-Fitting Constants	Standardization Constants
(1)	(2)	(3)	(4)	(5)
i)	A	Single web angle connection	$C_1 = 1.91 \times 10^4$ $C_2 = 1.30 \times 10^{11}$ $C_3 = 2.70 \times 10^{17}$	$K = d_a^{-2.4} t_c^{-1.81} g^{0.15}$
ii)	B	Double web angle connection	$C_1 = 1.64 \times 10^3$ $C_2 = 1.03 \times 10^{14}$ $C_3 = 8.18 \times 10^{25}$	$K = d_a^{-2.4} t_c^{-1.81} g^{0.15}$
iii)	C	Top and seat angle connection with double web angle	$C_1 = 2.24 \times 10^{-1}$ $C_2 = 1.86 \times 10^4$ $C_3 = 3.23 \times 10^8$	$K = d^{-1.287} l_a^{-1.128} t_c^{-0.415} l_a^{-0.694} (g - 0.5d_b)^{1.35}$
iv)	D	Top and seat angle connection without double web angle	$C_1 = 1.63 \times 10^3$ $C_2 = 7.25 \times 10^{14}$ $C_3 = 3.31 \times 10^{23}$	$K = d^{-1.5} t_a^{-0.5} l_a^{-0.7} d_b^{-1.1}$
v)	E	End plate connection without column stiffeners	$C_1 = 1.78 \times 10^4$ $C_2 = -9.55 \times 10^{16}$ $C_3 = 5.54 \times 10^{29}$	$K = d_b^{-2.4} t_p^{-0.4} t_f^{-1.5}$
vi)	F	End plate connection with column stiffeners	$C_1 = 2.60 \times 10^2$ $C_2 = 5.37 \times 10^{11}$ $C_3 = 1.31 \times 10^{22}$	$K = d_b^{-2.4} t_p^{-0.6}$
vii)	G	T-stub connection	$C_1 = 4.05 \times 10^2$ $C_2 = 4.45 \times 10^{13}$ $C_3 = -2.03 \times 10^{23}$	$K = d^{-1.5} t_f^{-0.5} l_t^{-0.7} d_b^{-1.1}$
viii)	H	Header plate connection	$C_1 = 3.87$ $C_2 = 2.71 \times 10^5$ $C_3 = 6.06 \times 10^{11}$	$K = t_p^{-1.6} g^{1.6} d_b^{-2.3} t_w^{-0.5}$

where (see Fig. 32)

$d$  = depth of beam

$d_a$  = depth of the angle, in mm

$d_b$  = diameter of the bolt, in mm

$d_s$  = center-to-centre of the outermost bolt of the end plate connection, in mm

$g$  = gauge distance of bolt line

$t_a$  = thickness of the top angle, in mm

$t_c$  = thickness of the web angle, in mm

$t_f$  = thickness of flange T-stub connector, in mm

$t_w$  = thickness of web of the beam in the connection, in mm

$t_p$  = thickness of end plate, header plate, in mm

$l_a$  = length of the angle, in mm

$l_t$  = length of the T-stub connector, in mm

NOTE — For preliminary analysis using a bilinear moment curvature relationship, the stiffness given in Table 45 may be assumed depending on the type of connection. The values are based on the secant stiffness at a rotation of 0.01 radian and typical dimension of connecting angle and other components as given in the table.

**Table 45 Secant Stiffness**  
(Table 44)

SI No.	Type of Connection	Dimension mm	Secant Stiffness kNm/radian
(1)	(2)	(3)	(4)
i)	Single web connection angle	$d_a = 250, t_a = 10, g = 35$	1 150
ii)	Double web-angle connection	$d_a = 250, t_a = 10, g = 77.5$	4 450
iii)	Top and seat angle connection without double web angle connection	$d_a = 300, t_a = 10, l_a = 140, d_b = 20$	2 730
iv)	Header plate	$d_p = 175, t_p = 10, g = 75, t_w = 7.5$	2 300

## F-5 COLUMN BASES

### F-5.1 Base Plates

Columns shall be provided with base plates capable of distributing the compressive forces in the compressed parts of the column over a bearing area such that the bearing pressure on the foundation does not exceed the design strength of the point. The design strength

of the joint between the base plate and the foundation shall be determined taking account of the material properties and dimensions of both the grout and the concrete foundation.

### F-5.2 Holding Down Bolts (Anchor Bolts)

**F-5.2.1** Holding down bolts shall be provided if necessary to resist the effects of the design loads.

They shall be designed to resist tension due to uplift forces and tension due to bending moments as appropriate.

**F-5.2.2** When calculating the tension forces due to bending moments, the lever arm shall not be taken as more than the distance between the centroid of the bearing area on the compression side and the centroid of the bolt group on the tension side, taking the tolerances on the positions of the holding down bolts into account.

**F-5.2.3** Holding down bolts shall either be anchored into the foundation by a hook or by a washer plate or by some other appropriate load distributing member embedded in the concrete.

**F-5.2.4** If no special elements for resisting the shear force are provided, such as block or bar shear connectors, it shall be demonstrated that sufficient resistance to transfer the shear force between the column and the foundation is provided by one of the following:

- a) Frictional resistance of the joint between the base plate and the foundation.
- b) Shear resistance of the holding down bolts.
- c) Shear resistance of the surrounding part of the foundation.
- d) Shear and bearing resistance of the shear key plates welded to the base plate and embedded in the pedestal/foundation.

## ANNEX G

(Clause 17.16)

### GENERAL RECOMMENDATIONS FOR STEELWORK TENDERS AND CONTRACTS

#### G-1 GENERAL

**G-1.1** The recommendations given in this Annex are in line with those generally adopted for steelwork construction and are meant for general information.

**G-1.2** These recommendations do not form part of the requirements of the standard and compliance with these is not necessary for the purpose of complying with this standard.

**G-1.3** The recommendations are unsuitable for inclusion as a block requirement in a contract, but in drawing up a contract the points mentioned should be given consideration.

#### G-2 EXCHANGE OF INFORMATION

Before the steelwork design is commenced, the building designer should be satisfied that the planning of the building, its dimensions and other principal factors meet the requirements of the building owner and comply with regulations of all authorities concerned. Collaboration of building designer and steelwork designer should begin at the outset of the project by joint consideration of the planning and of such questions as the stanchion spacing, materials to be used for the construction, and depth of basement.

#### G-3 INFORMATION REQUIRED BY THE STEELWORK DESIGNER

##### G-3.1 General

- a) Site plans showing in plan and elevation of

- the proposed location and main dimensions of the building or structure;
- b) Ground levels, existing and proposed;
- c) Particulars of buildings or other constructions which may have to remain on the actual site of the new building or structure during the erection of the steelwork;
- d) Particulars of adjacent buildings affecting, or affected by, the new work;
- e) Stipulation regarding the erection sequence or time schedule;
- f) Conditions affecting the position or continuity of members;
- g) Limits of length and weight of steel members in transit and erection;
- h) Drawings of the substructure, proposed or existing, showing:
  - 1) levels of stanchion foundations, if already determined;
  - 2) any details affecting the stanchion bases or anchor bolts;
  - 3) permissible bearing pressure on the foundation; and
  - 4) provisions for grouting.
- NOTE — In the case of new work, the substructure should be designed in accordance with the relevant standards dealing with foundations and substructure.
- j) The maximum wind velocity appropriate to the site (*see* IS 875); and

- k) Environmental factors, such as proximity to sea coast, and corrosive atmosphere. Reference to bye-laws and regulations affecting the steelwork design and construction.

### G-3.2 Further Information Relating to Buildings

- a) Plans of the floors and roof with principal dimensions, elevations and cross-sections showing heights between floor levels.
- b) The occupancy of the floors and the positions of any special loads should be given.
- c) The building drawings, which should be fully dimensioned, should preferably be to the scale of 1 to 100 and should show all stairs, fire-escapes, lifts, etc, suspended ceilings, flues and ducts for heating and ventilating. Doors and windows should be shown, as the openings may be taken into account in the computations of dead load.

Requirements should be given in respect of any maximum depth of beams or minimum head room.

Large-scale details should be given of any special features affecting the steelwork.

- d) The inclusive weight per m<sup>2</sup> of walls, floors, roofs, suspended ceilings, stairs and partitions, or particulars of their construction and finish for the computation of dead load. The plans should indicate the floors, which are to be designed to carry partitions. Where the layout of partitions is not known, or a given layout is liable to alteration, these facts should be specially noted so that allowance may be made for partitions in any position (*see* IS 875).
- e) The superimposed loads on the floors appropriate to the occupancy, as given in IS 875 or as otherwise required.
- f) Details of special loads from cranes, runways, tips, lifts, bunkers, tanks, plant and equipment.
- g) The grade of fire resistance appropriate to the occupancy as may be required.

## G-4 INFORMATION REQUIRED BY TENDERER ( IF NOT ALSO DESIGNER )

### G-4.1 General

- a) All information listed under G-3.1;
- b) Climatic conditions at site-seasonal variations of temperature, humidity, wind velocity and direction;
- c) Nature of soil. Results of the investigation of sub-soil at site of building or structure;

- d) Accessibility of site and details of power supply;
- e) Whether the steelwork contractor will be required to survey the site and set out or check the building or structure lines, foundations and levels;
- f) Setting-out plan of foundations, stanchions and levels of bases;
- g) Cross-sections and elevations of the steel structure, as necessary, with large-scale details of special features;
- h) Whether the connections are to be bolted, riveted or welded. Particular attention should be drawn to connections of a special nature, such as turned bolts, high strength friction grip bolts, long rivets and overhead welds;
- j) Quality of steel, and provisions for identification;
- k) Requirements in respect of protective paintings at works and on site, galvanizing or cement wash;
- m) Approximate dates for commencement and completion of erection;
- n) Details of any tests which have to be made during the course of erection or upon completion; and
- p) Schedule of quantities. Where the tenderer is required to take off quantities, a list should be given of the principal items to be included in the schedule.

### G-4.2 Additional Information Relating to Buildings

- a) Schedule of stanchions giving sizes, lengths and typical details of brackets, joints, etc;
- b) Plan of grillages showing sizes, lengths and levels of grillage beams and particulars of any stiffeners required;
- c) Plans of floor beams showing sizes, lengths and levels eccentricities and end moments. The beam reactions and details of the type of connection required should be shown on the plans;
- d) Plan of roof steelwork. For a flat roof, the plan should give particulars similar to those of a floor plan. Where the roof is pitched, details should be given of trusses, portals, purlins, bracing, etc;
- e) The steelwork drawings should preferably be to a scale of 1 to 100 and should give identification marks against all members; and
- f) Particulars of holes required for services, pipes, machinery fixings, etc. Such holes should preferably be drilled at works.

**G-4.3 Information Relating to Execution of Building Work**

- a) Supply of Materials;
- b) Weight of Steelwork for Payment;
- c) Wastage of Steel;
- d) Insurance, Freight and Transport from Shop to Site;
- e) Site Facilities for Erection;
- f) Tools and Plants;
- g) Mode and Terms of Payment;
- h) Schedules;
- j) *Forced Majeure* (Sections and provisions for liquidation and damages for delay in completion); and
- k) Escalation Sections.

**G-5 DETAILING**

In addition to the number of copies of the approved drawings or details required under the contract, dimensioned shop drawings or details should be submitted in duplicate to the engineer who should retain one copy and return the other to the steel supplier or fabricators with his comments, if any.

**G-6 TIME SCHEDULE**

As the dates on which subsequent trades can commence, depend on the progress of erection of the steel framing, the time schedule for the latter should be carefully drawn up and agreed to by the parties concerned at a joint meeting.

**G-7 PROCEDURE ON SITE**

The steelwork contractor should be responsible for the positioning and levelling of all steelwork. Any checking or approval of the setting out by the general contractor or the engineer should not relieve the steelwork contractor of his responsibilities in this respect.

**G-8 INSPECTION**

References may be made to IS 7215 for general guidance.

**G-8.1 Access to Contractor's Works**

The contractor should offer facilities for the inspection of the work at all stages.

**G-8.2 Inspection of Fabrication**

Unless otherwise, agreed, the inspection should be carried out at the place of fabrication. The contractor should be responsible for the accuracy of the work and for any error, which may be subsequently discovered.

**G-8.3 Inspection on Site**

To facilitate inspection, the contractor should during all working hours, have a foreman or properly accredited charge hand available on the site, together with a complete set of contract drawings and any further drawings and instructions which may have been issued from time to time.

**G-9 MAINTENANCE****G-9.1 General**

Where steelwork is to be encased in solid concrete, brickwork or masonry, the question of maintenance should not arise, but where steelwork is to be housed in hollow fire protection or is to be unprotected, particularly where the steelwork is exposed to a corroding agent, the question of painting or protective treatment of the steelwork should be given careful consideration at the construction stage, having regard to the special circumstances of the case.

**G-9.2 Connections**

Where connections are exposed to a corroding agent, they should be periodically inspected, and any corroded part should be thoroughly cleaned and painted.

**G-9.2.1** Where bolted connections are not solidly encased and are subject to vibratory effects of machinery or plant, they should be periodically inspected and all bolts tightened.

**ANNEX H**  
*(Informative)*  
**PLASTIC PROPERTIES OF BEAMS**

**Table 46 Plastic Properties of Beams (see also IS 808)**

Designation	Weight per Metre	Sectional Area	Depth of Section	Width of Flange	Thickness of Flange	Thickness of Web	Radii of Gyration		Section Modulus	Plastic Modulus	Shape Factor
(1)	(2)	(3)	(4)	(5)	(6)	(7)	( $r_x$ )	( $r_y$ )	(10)	(11)	(12)
	kg/m	cm <sup>2</sup>	mm	mm	mm	mm	cm	cm	cm <sup>3</sup>	cm <sup>3</sup>	( $Z_{pu}/Z_{ez}$ )
ISWB 600	*145.1	184.86	600	250	23.6	11.8	25.01	5.35	3 854.2	4 341.63	1.126 5
ISWB 600	*133.7	170.38	600	250	21.3	11.2	24.97	5.25	3 540.0	3 986.66	1.126 2
ISMB 600	*122.6	156.21	600	210	20.8	12	24.24	4.12	3 060.4	3 510.63	1.147 1
ISWB 550	*112.5	143.34	550	250	17.6	10.5	22.86	5.11	2 723.9	3 066.29	1.125 7
ISLB 600	*99.5	126.07	600	210	15.5	10.5	23.98	3.79	2 428.9	2 798.56	1.152 2
ISMB 550	103.7	132.11	550	190	19.3	11.2	22.16	3.73	2 359.8	2 711.98	1.149 2
ISWB 500	*95.2	121.22	500	250	14.7	9.9	20.77	4.96	2 091.6	2 351.35	1.124 2
ISLB 550	*86.3	109.97	550	190	15.0	9.9	21.99	3.48	1 933.2	2 228.16	1.152 6
ISMB 500	86.9	110.74	500	180	17.2	10.2	20.21	3.52	1 808.7	2 074.67	1.147 1
ISHB 450	92.5	117.89	450	250	13.7	11.3	18.50	5.08	1 793.3	2 030.95	1.132 5
ISHB 450	87.2	111.14	450	250	13.7	9.8	18.78	5.18	1 742.7	1 955.03	1.121 8
ISLB 500	*75.0	95.50	500	180	14.1	9.2	20.10	3.34	1 543.2	1 773.67	1.149 3
ISWB 450	79.4	101.15	450	200	15.4	9.2	18.63	4.11	1 558.1	1 760.59	1.130 0
ISHB 400	82.2	104.66	400	250	12.7	10.6	16.61	5.16	1 444.2	1 626.36	1.126 1
ISHB 400	77.4	98.66	400	250	12.7	9.1	16.87	5.26	1 404.2	1 556.33	1.115 5
ISMB 450	*72.4	92.27	450	150	17.4	9.4	18.15	3.01	1 350.7	1 533.36	1.150 0
ISLB 450	*65.3	83.14	450	170	13.4	8.6	18.20	3.20	1 223.8	1 401.35	1.145 1
ISWB 400	66.7	85.01	400	200	13.0	8.6	16.60	4.04	1 171.3	1 290.19	1.127 1
ISHB 350	72.4	92.21	350	250	11.6	10.1	14.65	5.22	1 131.6	1 268.69	1.121 2
ISHB 350	67.4	85.91	350	250	11.6	8.3	14.93	5.34	1 094.8	1 213.53	1.108 5
ISMB 400	*61.5	78.40	400	140	16.0	8.9	16.05	2.84	1 020.0	1 176.18	1.149 8
ISLB 400	*56.9	72.43	400	165	12.5	8	16.33	3.15	965.3	1 099.45	1.139 0
ISWB 350	56.9	72.50	350	200	11.4	8.0	14.63	4.03	887.0	995.49	1.122 3
ISHB 300	63.0	80.25	300	250	10.6	9.4	12.70	5.29	863.3	962.18	1.114 5
ISHB 300	58.8	74.85	300	250	10.6	7.6	12.95	5.41	836.3	921.68	1.102 1
ISMC 400	*49.4	62.93	400	100	15.3	8.1	15.48	2.83	754.1	891.03	1.181 6
ISMB 350	52.4	66.70	350	140	14.2	8.1	14.32	2.84	779.0	889.57	1.142 1
ISLB 350	49.5	63.01	350	165	11.4	7.4	14.45	3.17	751.9	851.11	1.132 0
ISLC 400	*45.7	58.25	400	100	14.0	8.0	15.50	2.81	699.5	825.02	1.179 4
ISWB 300	48.1	61.33	300	200	10.0	7.4	12.66	4.02	654.8	731.21	1.116 7
ISHB 250	54.7	69.71	250	250	9.7	8.8	10.70	5.37	638.7	708.43	1.109 2
ISLB 325	*43.1	54.90	325	165	9.8	7.0	13.41	3.05	607.7	687.76	1.131 7

Table 46 (Continued)

Designation (1)	Weight per Metre (2)	Sectional Area (3)	Depth of Section (D) mm (4)	Width of Flange ( $b_f$ ) mm (5)	Thickness of Flange ( $t_f$ ) mm (6)	Thickness of Web ( $t_w$ ) mm (7)	Radii of Gyration		Section Modulus ( $Z_{xx}$ ) cm <sup>3</sup> (10)	Plastic Modulus ( $Z_{pp}$ ) cm <sup>3</sup> (11)	Shape Factor ( $Z_{pp}/Z_{xx}$ ) (12)
							( $r_x$ ) cm (8)	( $r_y$ ) cm (9)			
ISHB 250	51.0	64.96	250	250	9.7	6.9	10.91	5.49	618.9	678.73	1.0967
ISMC 350	*42.1	53.66	350	100	13.5	8.1	13.66	2.83	571.9	672.19	1.1754
ISMB 300	*44.2	56.26	300	140	12.4	7.5	12.37	2.84	573.6	651.74	1.1362
ISLC 350	*38.8	49.47	350	100	12.5	7.4	13.72	2.82	532.1	622.95	1.1707
ISLB 300	*37.7	48.08	300	150	9.4	6.7	12.35	2.80	488.9	554.32	1.1338
ISHB 225	46.8	59.66	225	225	9.1	8.6	9.58	4.84	487.0	542.22	1.1134
ISWB 250	40.9	52.05	250	200	9.0	6.7	10.69	4.06	475.4	527.57	1.1097
ISHB 225	43.1	54.94	225	225	9.1	6.5	9.80	4.96	469.3	515.82	1.0987
ISMC 300	*35.8	45.64	300	90	13.6	7.6	11.81	2.61	424.2	496.77	1.1711
ISMB 250	37.3	47.55	250	125	12.5	6.9	10.39	2.65	410.5	465.71	1.1345
ISLC 300	*33.1	42.11	300	100	11.6	6.7	11.98	2.87	403.2	466.73	1.1576
ISLB 275	*33.0	42.02	275	140	8.8	6.4	11.31	2.61	392.4	443.09	1.1305
ISHB 200	40.0	50.94	200	200	9.0	7.8	8.55	4.42	372.2	414.23	1.1129
ISHB 200	37.3	47.54	200	200	9.0	6.1	8.71	4.51	360.8	397.23	1.1010
ISWB 225	33.9	43.24	225	150	9.9	6.4	9.52	3.22	348.5	389.93	1.1189
ISMC 250	*30.4	38.67	250	80	14.1	7.1	9.94	2.38	305.3	356.72	1.1684
ISMB 225	31.2	39.72	225	110	11.8	6.5	9.31	2.34	305.9	348.27	1.1385
ISLB 250	*27.9	35.53	250	125	8.2	6.1	10.23	2.33	297.4	338.69	1.1388
ISLC 250	28.0	35.65	250	100	10.7	6.1	10.17	2.89	295.0	338.11	1.1462
ISWB 200	28.8	36.71	200	140	9.0	6.1	8.46	2.99	262.5	293.99	1.1200
ISMC 225	*25.9	33.01	225	80	12.4	6.4	9.03	2.38	239.5	277.93	1.1605
ISLC 225	*24.0	30.53	225	90	10.2	5.8	9.14	2.62	226.5	260.13	1.1485
ISLB 225	*23.5	29.92	225	100	8.6	5.8	9.15	1.94	222.4	254.72	1.1453
ISMB 200	25.4	32.33	200	100	10.8	5.7	8.32	2.15	223.5	253.86	1.1358
ISHB 150	34.6	44.08	150	150	11.8	11.8	6.09	3.35	218.1	251.64	1.1538
ISHB 150	30.6	34.48	150	150	9.0	8.4	6.29	3.44	205.3	232.52	1.1326
ISHB 150	27.1	34.48	150	150	9.0	5.4	6.50	3.54	194.1	215.64	1.1110
ISMC 200	*22.1	28.21	200	75	11.4	6.1	8.03	2.23	181.9	211.25	1.1614
ISLC 200	*20.6	26.22	200	75	10.8	5.5	8.11	2.37	172.6	198.77	1.1516
ISWB 175	22.1	28.11	175	125	7.4	5.8	7.33	2.59	172.5	194.20	1.1258
ISLB 200	*19.8	25.27	200	100	7.3	5.4	8.19	2.13	169.7	184.34	1.1370
ISMB 175	*19.3	24.62	175	90	8.6	5.5	7.19	1.86	145.4	166.08	1.1422
ISMC 175	*19.1	24.38	175	75	10.2	5.7	7.08	2.23	139.8	161.65	1.1563
ISLC 175	*17.6	22.40	175	75	9.5	5.1	7.16	2.38	131.3	150.36	1.1452
ISLB 175	*16.7	21.30	175	90	6.9	5.1	7.17	1.93	125.3	143.30	1.1437
ISJB 225	*12.8	16.28	225	80	5.0	3.7	8.97	1.58	116.3	134.15	1.1535
ISJC 200	13.9	17.8	200	70	7.1	4.1	8.08	2.18	116.1	133.12	1.1465
ISWB 150	17.0	21.67	150	100	7.0	5.4	6.22	2.09	111.9	126.86	1.1337

Table 46 (Concluded)

Designation (1)	Weight per Metre (2)	Sectional Area (3)	Depth of Section (D) (4)	Width of Flange ( $b_f$ ) (5)	Thickness of Flange ( $t_f$ ) (6)	Thickness of Web ( $t_w$ ) (7)	Radii of Gyration		Section Modulus ( $Z_{xx}$ ) (10)	Plastic Modulus ( $Z_{px}$ ) (11)	Shape Factor ( $Z_{px}/Z_{xx}$ ) (12)
							( $r_x$ ) (8)	( $r_y$ ) (9)			
ISMC 150	16.4	20.88	150	75	9.0	5.4	6.11	2.21	103.9	119.82	1.153 3
ISMB 150	14.9	19.00	150	80	7.6	4.8	6.18	1.66	96.9	110.48	1.140 1
ISLC 150	14.4	18.36	150	75	7.8	4.8	6.16	2.37	93.0	106.17	1.141 6
ISLB 150	14.2	18.08	150	80	6.8	4.8	6.17	1.75	91.8	104.50	1.138 4
ISJC 175	*11.2	14.24	175	60	6.9	3.6	7.11	1.88	82.3	94.22	1.144 9
ISJB 200	*9.9	12.64	200	60	5.0	3.4	7.86	1.17	78.1	90.89	1.163 9
ISMB 125	13.0	16.60	125	75	7.6	4.4	5.20	1.62	71.8	81.85	1.139 9
ISMC 125	12.7	16.19	125	65	8.1	5.0	5.07	1.92	66.6	77.15	1.158 5
ISLB 125	11.9	15.12	125	75	6.5	4.4	5.19	1.69	65.1	73.93	1.135 6
ISJC 150	9.9	12.65	150	55	6.9	3.6	6.9	1.73	62.8	72.04	1.147 2
ISLC 125	10.7	13.67	125	65	6.6	4.4	5.11	2.05	57.1	65.45	1.146 2
ISJB 175	*8.1	10.28	175	50	4.6	3.0	6.83	0.97	54.8	64.22	1.179 9
ISMB 100	8.9	11.4	100	50	7.0	4.2	4.00	1.05	36.6	41.68	1.138 9
ISJB 150	*7.1	9.01	150	50	4.6	3.0	5.98	1.01	42.9	49.57	1.155 6
ISJC 125	7.9	10.07	125	50	6.6	3.0	5.18	1.60	43.2	49.08	1.136 2
ISMC 100	9.2	11.70	100	50	7.5	4.7	4.00	1.49	37.3	43.83	1.175 0
ISLB 100	8.0	10.21	100	50	6.4	4.0	4.06	1.12	33.6	38.89	1.157 3
ISLC 100	7.9	10.02	100	50	6.4	4.0	4.06	1.57	32.9	38.09	1.157 6
ISJC 100	*5.8	7.41	100	45	5.1	3.0	4.09	1.42	24.8	28.38	1.144 2
ISMC 75	6.8	8.67	75	40	7.3	4.4	2.96	1.21	20.8	24.17	1.190 4
ISLB 75	6.1	7.71	75	50	5.0	3.7	3.07	1.14	19.4	22.35	1.152 2
ISLC 75	*5.7	7.26	75	40	6.0	3.7	3.02	1.26	17.6	20.61	1.171 0

NOTE — Sections having 'weight per meter' marked with an asterisk (\*) may be chosen as the section is lighter having high  $Z_p$  as compared to sections below it.

## ANNEX J

(Foreword)

## COMMITTEE COMPOSITION

## Structural Engineering and Structural Sections Sectional Committee, CED 7

<i>Organization</i>	<i>Representative(s)</i>
Indian Institute of Technology, Chennai	DR V. KALYANARAMAN ( <i>Chairman</i> )
In personal capacity (P-244 Scheme VI M, CIT Road, P.O. Kankurgachi, Kolkata 700054)	SHRI A. BASU ( <i>Former Chairman</i> )
Bengal Engineering & Science University, Howrah	DR SAIBAL KUMAR GHOSH DR SUBRATA CHACKRABORTY ( <i>Alternate</i> )
Bhillai Institute of Technology, Durg	DR MOHAN GUPTA
C. R. Narayana Rao, Chennai	DR C. N. SRINIVASAN SHRI C. R. ARVIND ( <i>Alternate</i> )
Central Electricity Authority, New Delhi	SHRI KARNAIL SINGH SHRI S. K. ROY CHOWDHURY ( <i>Alternate</i> )
Central Public Works Department, New Delhi	CHIEF ENGINEER SUPERINTENDING ENGINEER ( <i>Alternate</i> )
Centre for High Technology, New Delhi	SHRI S. K. BAHAL
Central Water Commission, New Delhi	DIRECTOR, GATES DESIGN SHRI A. K. BAJAJ ( <i>Alternate</i> )
Consulting Engineering Services India (Pvt) Ltd, New Delhi	SHRI S. GHOSH SHRI S. K. HAZRA CHOWDHURY ( <i>Alternate</i> )
Construma Consultancy Pvt Limited, Mumbai	DR HARSHAVARDHAN SUBBARAO
Development Commissioner for Iron & Steel Control, Kolkata	SHRI B. D. GHOSH SHRI R. N. GUIN ( <i>Alternate</i> )
Directorate General of Supplies & Disposals, New Delhi	SHRI R. K. AGARWAL SHRI S. K. AGARWAL ( <i>Alternate</i> )
Engineer-in-Chief's Branch, New Delhi	SHRI J. B. SHARMA SHRI YOGESH KUMAR SINGHAL ( <i>Alternate</i> )
Engineers India Limited, New Delhi	SHRI V. Y. SALPEKAR SHRI ARVIND KUMAR ( <i>Alternate</i> )
GAIL India Ltd, New Delhi	SHRI S. SHYAM SUNDER
Gammon India Limited, Mumbai	SHRI V. M. DHARAP SHRI M. V. JATKAR ( <i>Alternate</i> )
Hindalco Industries Limited, Mirzapur	DR. J. MUKHOPADYAY SHRI AJAY KUMAR AGARWAL ( <i>Alternate</i> )
Hindustan Steel Works Construction Limited, Kolkata	SUPERINTENDING ENGINEER DEPUTY CHIEF ENGINEER ( <i>Alternate</i> )
Indian Institute of Technology, Chennai	DR SATISH KUMAR
Indian Oil Corporation, Noida	SHRI T. BANDYOPADHYAY SHRI P. V. RAJARAM ( <i>Alternate</i> )
Institute of Steel Development & Growth (INSDAG), Kolkata	DR T. K. BANDYOPADHYAY
Institution of Engineers (India), Kolkata	SHRI P. B. VIJAY
Jindal Vijaya Nagar Steel Limited, Bellary	DIRECTOR
Larsen & Toubro Limited, Chennai	SHRI T. VENKATESH RAO SHRIMATI M. F. FEBIN ( <i>Alternate</i> )
M. N. Dastur & Company Pvt Limited, Kolkata	SHRI SATYAKI SEN SHRI PRATIP BHATTACHARYA ( <i>Alternate</i> )
Metallurgical & Engg Consultants Limited, Ranchi	GENERAL MANAGER SHRI K. K. DE ( <i>Alternate</i> )
Ministry of Road Transport & Highways (Rep. IRC), New Delhi	SECRETARY IRC DIRECTOR IRC ( <i>Alternate</i> )



## IS 800 : 2007

<i>Organization</i>	<i>Representative(s)</i>
Mumbai Port Trust, Mumbai	SUPERINTENDING ENGINEER EXECUTIVE ENGINEER ( <i>Alternate</i> )
National Thermal Power Corporation, Noida	DR S. N. MANDAL SHRI R. K. GUPTA ( <i>Alternate</i> )
Northern Railway, New Delhi	REPRESENTATIVE
Oil and Natural Gas Commission, Dehradun	REPRESENTATIVE
Oil Industry Safety Directorate, New Delhi	SHRI S. K. NANDY
Research, Designs & Standards Organization, Lucknow	EXECUTIVE DIRECTOR DIRECTOR ( <i>Alternate</i> )
Rites Ltd, Gurgaon	SHRI SRINIVASAN
Steel Authority of India Limited, Ranchi	SHRI T. K. GHOSAL SHRI R. M. CHATTOPADHYAY ( <i>Alternate</i> )
Steel Authority of India Limited, Bokaro	SHRI S. K. BANERJEE SHRI SHYAMA NAND TERIAR ( <i>Alternate</i> )
Steel Authority of India Limited, Bhilai	SHRI BHARAT LAL SHRI RANJAN HALDAR ( <i>Alternate</i> )
Steel Re-Rolling Mills Association of India, Kolkata	SHRI R. P. BHATIA SHRI ANIL KUMAR JAVERI ( <i>Alternate</i> )
STUP Consultants Pvt Ltd, Kolkata	SHRI A. GHOSHAL DR N. BANDOPADHYAY ( <i>Alternate</i> )
Structural Engineering Research Centre, Chennai	DR N. LAKSHMANAN DR S. SEETHARAMAN ( <i>Alternate</i> )
Visakhapatnam Steel Project, Visakhapatnam	SHRI U. V. SWAMY SHRI S. GHOSH ( <i>Alternate</i> )
BIS Directorate General	SHRI A. K. SAINI, Scientist 'F' & Head (CED) [Representing Director General ( <i>Ex-officio Member</i> )] SHRI S. K. JAIN, Scientist 'F' & Head ( <i>Former</i> ) (CED) [Representing Director General ( <i>Ex-officio Member</i> )]

### *Member Secretaries*

SHRI J. ROY CHOWDHURY  
Scientist 'E' (CED), BIS  
SHRI S. CHATURVEDI  
Scientist 'E' (CED), BIS  
(Former Member Secretary)  
SHRI AMAN DEEP GARG  
Scientist 'B' (CED), BIS  
(Former Member Secretary)

### Use of Structural Steel in General Building Construction Subcommittee, CED 7:2

Ministry of Railways, New Delhi	SHRI A. K. HARIT ( <i>Convener</i> )
Bengal Engineering & Science University, Howrah	PROFESSOR & HEAD
Bharat Heavy Electricals Limited, Trichy	SHRI R. MATHIANNAL SHRI R. JEYAKUMAR ( <i>Alternate</i> )
Braithwait & Company Limited, Hoogly	DEPUTY MANAGER ASSISTANT MANAGER ( <i>Alternate</i> )
C. R. Narayana Rao, Chennai	DR C. N. SRINIVASAN SHRI C. R. ARVIND ( <i>Alternate</i> )
Central Electricity Authority, New Delhi	SHRI A. K. JAIN SHRI PRAVEEN VASISTH ( <i>Alternate</i> )

<i>Organization</i>	<i>Representative(s)</i>
Engineer-in-Chief's Branch, New Delhi	SHRI YOGESH KUMAR SINGHAL
Engineers India Limited, New Delhi	SHRI ARVIND KUMAR SHRI S. B. JAIN ( <i>Alternate</i> )
Indian Institute of Technology, New Delhi	HEAD
Indian Institute of Technology, Kanpur	DR DURGESH C. RAI DR C. V. R. MURTHY ( <i>Alternate</i> )
Institute of Steel Development and Growth (INSDAG), Kolkata	DR T. K. BANDYOPADHYAY
Jadavpur University, Kolkata	PROF K. K. GHOSH
Larsen & Toubro Limited, Chennai	DR. K. NATARAJAN
M. N. Dastur Company Pvt Limited, Kolkata	SHRI S. R. KULKARNI SHRI SATYAKI SEN ( <i>Alternate</i> )
Metallurgical & Engineering Consultants Limited, Ranchi	SHRI A. K. CHAKROBORTY SHRI R. PRAMANIK ( <i>Alternate</i> )
National Thermal Power Corporation, Noida	SHRI R. K. GUPTA SHRI BHARAT ROHRA ( <i>Alternate</i> )
Public Works Department, Mumbai	SHRI K. S. JANGDE
Research, Designs and Standards Organization, Lucknow	DIRECTOR
Richardson & Cruddas Limited, Nagpur	SHRI S. K. DATTA
Steel Authority of India Ltd. Bokaro	SHRI S. K. BANERJEE SHRI SHYAMA NAND TERIAR ( <i>Alternate</i> )
Structural Engineering Research Centre, Chennai	DR D. S. RAMCHANDRAMURTHY SHRI G. S. PALANI ( <i>Alternate</i> )
Tata Iron & Steel Company Limited, Jamshedpur	SHRI S. N. GHATAK SHRI K. S. RANGANATHAN ( <i>Alternate</i> )

#### Ad-hoc Group for Preparation of Final Draft for Revision of IS 800

Indian Institute of Technology, Chennai	DR V. KALYANARAMAN
Institute of Steel Development & Growth (INSDAG), Kolkata	DR T. K. BANDYOPADHYAY

## Bureau of Indian Standards

BIS is a statutory institution established under the *Bureau of Indian Standards Act, 1986* to promote harmonious development of the activities of standardization, marking and quality certification of goods and attending to connected matters in the country.

### Copyright

BIS has the copyright of all its publications. No part of these publications may be reproduced in any form without the prior permission in writing of BIS. This does not preclude the free use, in the course of implementing the standard, of necessary details, such as symbols and sizes, type or grade designations. Enquiries relating to copyright be addressed to the Director (Publications), BIS.

### Review of Indian Standards

Amendments are issued to standards as the need arises on the basis of comments. Standards are also reviewed periodically; a standard along with amendments is reaffirmed when such review indicates that no changes are needed; if the review indicates that changes are needed, it is taken up for revision. Users of Indian Standards should ascertain that they are in possession of the latest amendments or edition by referring to the latest issue of 'BIS Catalogue' and 'Standards : Monthly Additions'.

This Indian Standard has been developed from Doc : No. CED 7 (7182).

### Amendments Issued Since Publication

Amend No.	Date of Issue	Text Affected

### BUREAU OF INDIAN STANDARDS

#### Headquarters :

Manak Bhavan, 9 Bahadur Shah Zafar Marg, New Delhi 110 002  
Telephones : 2323 0131, 2323 3375, 2323 9402

Telegrams : Manaksanstha  
(Common to all offices)

#### Regional Offices :

Central : Manak Bhavan, 9 Bahadur Shah Zafar Marg  
NEW DELHI 110 002

Telephone  
{ 2323 7617  
2323 3841

Eastern : 1/14 C.I.T. Scheme VII M, V. I. P. Road, Kankurgachi  
KOLKATA 700 054

{ 2337 8499, 2337 8561  
2337 8626, 2337 9120

Northern : SCO 335-336, Sector 34-A, CHANDIGARH 160 022

{ 260 3843  
260 9285

Southern : C.I.T. Campus, IV Cross Road, CHENNAI 600 113

{ 2254 1216, 2254 1442  
2254 2519, 2254 2315

Western : Manakalaya, E9 MIDC, Marol, Andheri (East)  
MUMBAI 400 093

{ 2832 9295, 2832 7858  
2832 7891, 2832 7892

Branches : AHMEDABAD. BANGALORE. BHOPAL. BHUBANESHWAR. COIMBATORE. FARIDABAD.  
GHAZIABAD. GUWAHATI. HYDERABAD. JAIPUR. KANPUR. LUCKNOW. NAGPUR.  
PARWANOO. PATNA. PUNE. RAJKOT. THIRUVANANTHAPURAM. VISAKHAPATNAM.